

BioMidi & BioPlus

INSTRUCTIONS FOR USE

MODELS: BioMidi: 425, 625, EF425
BioPlus: 500, 600D, 600W, 660D, 660W, 930, 1270, 1400,
EF600W, EF660W

Original Instructions for use

Item No.: 765041538
Revision No.: 20260401
Language: English



Biostorage you can depend on

Quick Guide – BioMidi & BioPlus

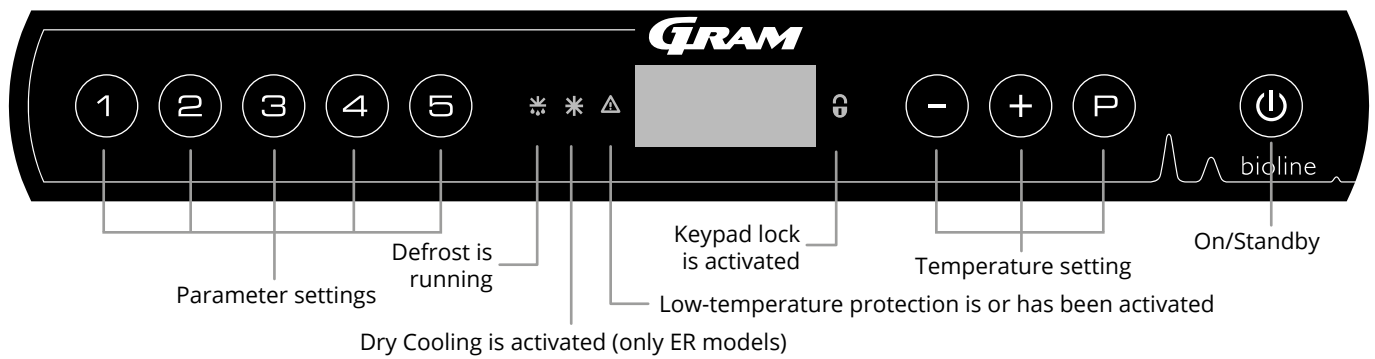

On/Standby

Press the **⏻** key to turn the cabinet on. Press the **⏻** key for 6 seconds to switch to standby. The software version of the cabinet will be shown when the cabinet is turned on, followed by the variant and a display test. The cabinet is ready when the temperature is displayed. The cabinet will automatically start a defrost-cycle when turned on, and terminate it again after a system check.

Setting the temperature

Temperature adjustments are done by holding the **P** key and pressing either **-** or **+**. Confirm the settings by letting go of the keys.

User menu and alarm settings

Menu Access P + 1 →	↓	→		
	dC*			Dry cooling [HO=Off/H1=On]
Local alarm settings	LAL	LhL	[° C]	Upper alarm limit. Code for activated alarm [A2]
		LLL	[° C]	Lower alarm limit. Code for activated alarm [A3]
		Lhd	[min.]	Delay of upper alarm limit
		LLd	[min.]	Delay of lower alarm limit
		dA	On/Off	Door alarm. Code for activated alarm [A1]. [1=On/0=Off]
		dAd	[min.]	Delay of door alarm
		BU	On/Off	Acoustic signal for alarm codes [A1], [A2] and [A3]. [1=On/0=Off]
External alarm settings	EAL	EhL	[° C]	Upper alarm limit. Code for activated alarm [A4]
		ELL	[° C]	Lower alarm limit. Code for activated alarm [A5]
		Ehd	[min.]	Delay of upper alarm limit
		ELd	[min.]	Delay of lower alarm limit
		dA	On/Off	Door alarm. Code for activated alarm [A1]. [1=On/0=Off]
		dAd	[min.]	Delay of external door alarm
		BU	On/Off	Acoustic signal for external alarm codes [A1], [A4], [A5]. [1=On/0=Off]
Offset of sensors	CAL	cA	[° K]	Calibration of A-sensor. Reference sensor for the refrigeration system
		cE	[° K]	Calibration of E-sensor. Reference sensor for the display and alarms
		cF	[° K]	Offset setting for F-sensor. Reference sensor for the low-temperature protection
Low-temperature protection	FP	ACt	On/off	Activation/deactivation of low-temperature protection
		tES	On	Test of low-temperature protection
		SEt	[° C]	Setting of the cut-off temperature for the low-temperature protection
		PrE	[...]	Read-out of the real-time temperature of the F-sensor
	ALL			Activation of escorted alarm limits. [FAS]=limits/[ESC]=follows setpoint
	dEF			Number of defrosts per 24 hours (4 is factory setting)
	dPS			Reference sensor for the display (A, E or F)

Other Shortcuts

Keys	Duration	Function
P + ⏻	> 3 seconds	Start or stop a defrost
⏻ + 1	> 6 seconds	Activating/deactivating the keypad lock
P	-	Shows the temperature setpoint value
+	-	Shows the highest registered temperature spike (since the last reset of the alarm history)
-	-	Shows the lowest registered temperature spike (since the last reset of the alarm history)
+ + -	> 3 seconds	Clear and reset alarm history
P + 1 + 3	> 6 seconds	Reset of the set parameters. Restores factory settings
P + 1	> 3 seconds	Access to user menu and alarm settings

* Only ER

Example: Setting the upper limits for the alarms; LhL

- ↳ Press and hold (P) + (1) until the display shows LAL
- ↳ Press (P) to select LAL. The upper alarm (LhL) limit is now shown in the display
- ↳ Press (P) to select LhL, 25 is now shown in the display
- ↳ Press (-) or (+) to set the desired value
- ↳ Press (P) to return to LAL
- ↳ Press (+) to reach the next level, LLL
- ↳ Lhd, LLd, dA, dAd and BU are located on the same level
- ↳ Leave the user menu by pressing (P) several times until the cabinet's temperature is shown in the display

Alarm codes	[A1]	Door alarm "dAd" from LAL and/or EAL has been activated
	[A2]	The upper alarm limit, (LhL) is or has been activated
	[A3]	The lower alarm limit, (LLL) alarm is or has been activated
	[A4]	External high alarm EhL is or has been activated (see page 42)
	[A5]	External low alarm ELL is or has been activated (see page 42)

Canceling an acoustic alarm

Canceling a door alarm: [A1] Flashes in the display. Press (P) to cancel.

Canceling a temperature alarm: [A2, A3] Flashes in the display. Press (P) to cancel.

The display will continue to flash if the temperature is outside the alarm limits, and will continue so until the temperature has recovered.

Read-out of the max./min. temperature

Read the highest recorded temperature inside the cabinet by holding down (+). Read the lowest recorded temperature inside the cabinet by holding down (-).

Reading the alarm history - Example [A2]

[A2] Flashes in the display. This means that the temperature has exceeded the set value for the upper temperature limit, LhL.

- Press (P) to cancel the [A2]. The display continues to flash, indicating that there is information in the alarm history.
- Press (+), Htt (High temperature time) is shown. Press (P) to see for how long the temperature was above the set alarm limit.
- Press (P) to return to Htt. Press (+) to reach Ht (Highest temperature).
- Press (P) to read the highest recorded temperature during Htt. Press (P) to return to Ht and press (P) again to leave the alarm history function.

The procedure for reading an [A3] alarm is identical, apart from entering the alarm history with the (-) key. When reading out temperatures below set limits, the parameters are Ltt and Lt. A flashing display with no alarm codes indicates that the alarm codes have been canceled, but the alarm system contains information.

Resetting the alarm temperature and the alarm history

Resetting of the max./min. and the alarm history is done by holding (-) and (+) for more than three seconds. An acoustic signal will be given when reset is complete.

Sensor read-out and error codes

Menu Access (P) + (5) →	↓	(P) → [° C]	Display code and its message	
Sensor for refrigeration system	P-A	Value on sensor for refrigeration system	F1	Error on sensor for refrigeration system
Sensor for evaporator	P-b	Value for evaporator sensor	F2	Error on evaporator sensor
Sensor for condensor	P-C	Value for condensor sensor	F3	Error on condensor sensor
Sensor for display and alarms	P-E	Value for display and alarm sensor	F5	Error on sensor for display and alarms
An overheated condensor can be caused by a clogged condensor - Clean the condensor			F7	Overheated condensor
Open door indicator. Alarm [A1] will activate if the door is open longer than alarm limits			-0-	Door open

Table of content

Quick Guide – BioMidi & BioPlus	2	General info	55
Table of content	4	Responsibility	55
Safety	5	Type/number plate	56
Before you proceed	5	Defrost water	57
Cabinet components	6	Door self-closing mechanism	58
BioPlus	6	Door lock	59
BioMidi	8	Access port	60
Installation	10	Important	61
Initial setup	10	Disposal	62
Anti tilt bracket	12	Datasheet	63
Surroundings	13	BioMidi 425	63
Voltage-free contact	15	BioMidi 625	68
Connection to power	16	BioPlus 500	73
Equipotential bonding	18	BioPlus 600D	78
Options assembly	20	BioPlus 600W	83
Introduction	20	BioPlus 660D	91
Shelf carriers	21	BioPlus 660W	96
Perforated shelf	22	BioPlus EF600W	105
Wire shelf	23	BioPlus EF660W	110
Carriers for aluminium drawer	24	BioPlus 930	113
Aluminium drawer	25	BioPlus 1270	118
Carriers for 40 kg drawer	26	BioPlus 1400	127
40 kg drawer	27	Declaration of conformity	135
How to lock the shelf on a 40 kg drawer	28	BioMidi	135
Carriers for 30 kg drawer	30	BioMidi – Accessory code 69	136
30 kg drawer	31	BioPlus	137
How to lock the 30 kg drawer	32	BioPlus – Accessory code 69	138
Start-up	34	Piping diagram	139
The digital display	34	Piping diagram	139
Walkthrough of menu	35	BioMidi/BioPlus	139
Error codes	36	BioPlus – With dual refrigeration	140
Dry cool	37	Wiring diagram	141
Local alarm settings	38	BioPlus RF – With SSR	141
Local high alarm	38	BioPlus ER – With SSR	142
Local low alarm	38	BioPlus ER – With SSR	142
Local high alarm delay	39	BioPlus EF600/660 – With SSR	143
Local low alarm delay	39	BioPlus ER1270/1400 – With SSR	144
On/Off local door alarm	40	BioPlus RF1270/1400 –	
Delay for local door alarm	40	With dual compressor – With SSR	145
Buzzer – Acoustic local alarms	41	BioPlus ER1270/1400 –	
External alarm settings	42	With dual compressor – With SSR	146
External high alarm	42	BioPlus RF/EF – With dual compressor	
External low alarm	42	– With SSR	147
External high alarm delay	43	BioPlus ER1270/1400 – With dual compressor –	
External low alarm delay	43	With LTP and SSR	148
On/Off external door alarm	44	BioMidi RR425/625 – With LTP	149
External door alarm delay	44	BioMidi RF425/625 – With SSR	150
Buzzer – External acoustic settings	45	BioMidi EF425 – With SSR	151
Parameter settings	46	General maintenance information	152
Sensor offset	46	Maintenance plan	153
Escorted/set alarm limits	48	General cleaning information	155
Defrosts/24 hours	49	Cleaning plan	156
Display sensor	50	FAQ	160
Electric low-temperature protection	51	IQ & OQ	162
Ordinary use	52	Installation Qualification	162
Load line	52	Operation Qualification	162
Regular maintenance	53	PQ	170
Cleaning	53	Performance Qualification	170
Door gasket	54	Index	182

Copyright © 2006- Gram BioLine, a division of Gram Scientific ApS, Denmark. All rights reserved.

The content of this publication is owned by Gram BioLine, unless otherwise noted, and is protected by Danish and international copyright laws and provisions. Information and images may not be used, copied or transferred without the express written permission of Gram BioLine.

Manufactured by
Gram Scientific ApS
Aage Grams Vej 1 · 6500 Vojens · Denmark
Tel: +45 73 20 13 00 · Fax: +45 73 20 13 01
e-mail: info@gram-bioline.com
www.gram-bioline.com

Before you proceed

Make sure to read the instructions for use thoroughly before using the cabinet for the first time. In the event of need for product support. Do not hesitate to contact us at: support@gram-bioline.com

This instructions for use is intended for the following product series:

BioMidi and BioPlus

We recommend that you read this instructions for use thoroughly before using the cabinet for the first time. Gram Bioline does not guarantee safe operation if the cabinet is used for anything other than its intended use. Contents of the instructions for use can be subject to change without notice. No part of this instructions for use may be reproduced in any form without expressed written consent of Gram Bioline. Gram Bioline guarantees the cabinet under certain warranty conditions. Gram Bioline is not responsible for any loss or damage of content.

This instructions for use should be considered as an integral part of the cabinet and should be stored close to the cabinet and to be easily accessible. If the instructions for use is lost, please refer to your local distributor or Gram Bioline for a replacement. For current versions of the instructions for use, please go www.gram-bioline.com.

Intended Use

Gram BioLine BioPlus and BioMidi refrigerators (RR and ER) and freezers (RF and EF) are designed and manufactured to provide safe and precise conditions for the items stored.

The cabinets are designed for the following operating ranges:

RR: +2/+20 °C

ER: -2/+20 °C

RF: -25/-5 °C

EF (BioPlus): -35/-5 °C

EF (BioMidi): -40/-5 °C

at the maximum ambient temperature specified in this instructions for use, and a maximum relative humidity of 70%. The user must ensure that the cabinet is used in accordance with its intended use.

Abnormal use or use conflicting with the intended use or guidelines stipulated in the product documentation can lead to: danger to patient safety, damage to stored items, damage to cabinet and danger to user. Gram BioLine equipment is designed to be used in a system with monitored additional independent alarms to ensure timely reaction to alarms and thereby maximum item safety. When storing valuable or temperature-sensitive materials or products, it is advisable to employ a continuously monitoring autonomous alarm system. This alarm system should be designed in a manner that allows authorised individuals to promptly detect each alarm state and take the necessary corrective actions.

Symbols used throughout the instructions for use



Hazard



Risk of fire/flammable materials



Risk of electric shock



Risk of explosion/explosive materials



Risk of material damage



Info



Risk of personal injury



ATEX information



Risk of burning/freezing

Cabinet components

BioPlus

This part describes the main components pertinent to the user.

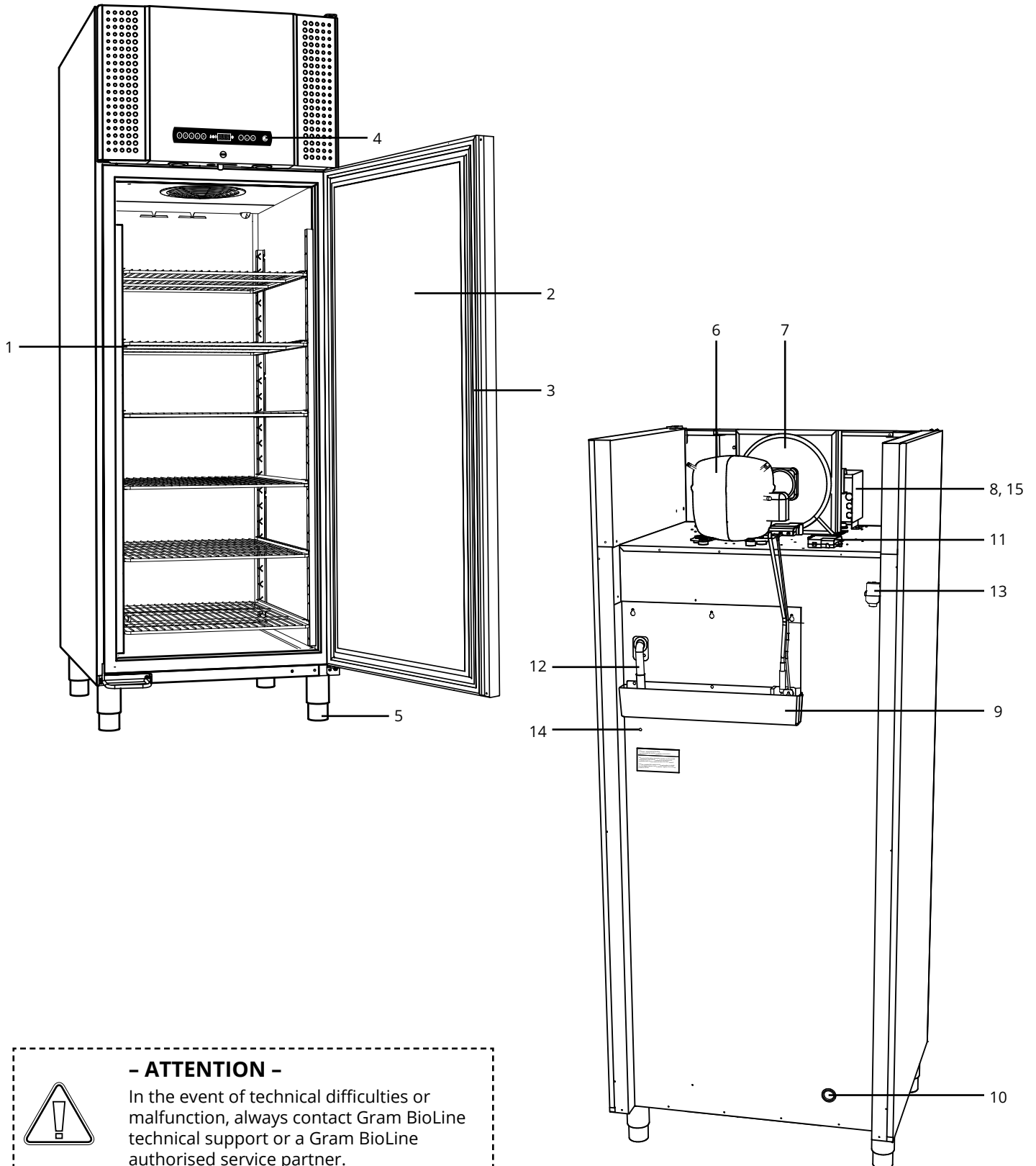

- ATTENTION -

In the event of technical difficulties or malfunction, always contact Gram BioLine technical support or a Gram BioLine authorised service partner.

- 1. Shelves and wall rails**
Ensure that the shelves are fixed correctly, before exerting load on them.
All shelves or drawers must be supported by at least two shelf or drawer supports each.
- 2. Door**
Ensure that the door is closed completely after use.
To minimise fluctuations in temperature, make the door openings as brief as possible.
- 3. Door gasket**
Ensure that the gasket is pliable and in good working order.
Keep the door gasket clean, find instructions in this instructions for use.
- 4. Digital display for controller**
Use the display to show the cabinet temperature and, to set the parameters described in this instructions for use.
- 5. Base of cabinet**
Ensure cabinets with legs are levelled properly and cabinets with castors are placed on a level surface and locked as mentioned in this instructions for use.
- 6. Compressor**
Ensure it is not dented or shows any other signs of damage.
- 7. Condenser and fan**
Ensure it is not dented or shows any other signs of damage.
- 8. Controller for refrigeration system**
Enclosure for controller, sensors and other parts that monitor and manage the refrigeration system.
Ensure it is not dented or shows any other signs of damage.
- 9. Re-evaporation tray**
Ensure it is not cracked or shows any other signs of damage.
It is recommended to clean it before applying power to the cabinet for the first time.
- 10. Access port**
Used to lead sensors and similar into the cabinet. Ensure that the access port is sealed properly prior to start up.
- 11. Terminal box for voltage-free contact**
Used to connect to an external alarm system. Instructions for connection is found in this instructions for use.
Remember to set the external alarms (EAL).
- 12. Defrost water tube**
Outlet for the defrost water coming from the evaporator tray inside the cabinet.
Ensure it is not damaged or shows signs of damage.
- 13. Pressure equalisation valve**
Used to equalise pressure inside the cabinet when opening the door.
Ensure its not damaged or shows signs of damage.
- 14. Equipotential Bonding**
To ensure compliance with ATEX regulations EN 60079-14.
See installation section for specifications.
- 15. Preload cover to access mains terminal connection**
Mains power connection, secured mechanically by the preload cover. Find installation guide in this instructions for use.



- ATTENTION -

If parts show signs of damage; do not use the cabinet and contact Gram BioLine or supplier for further aid.

BioMidi

This part describes the main components pertinent to the user.

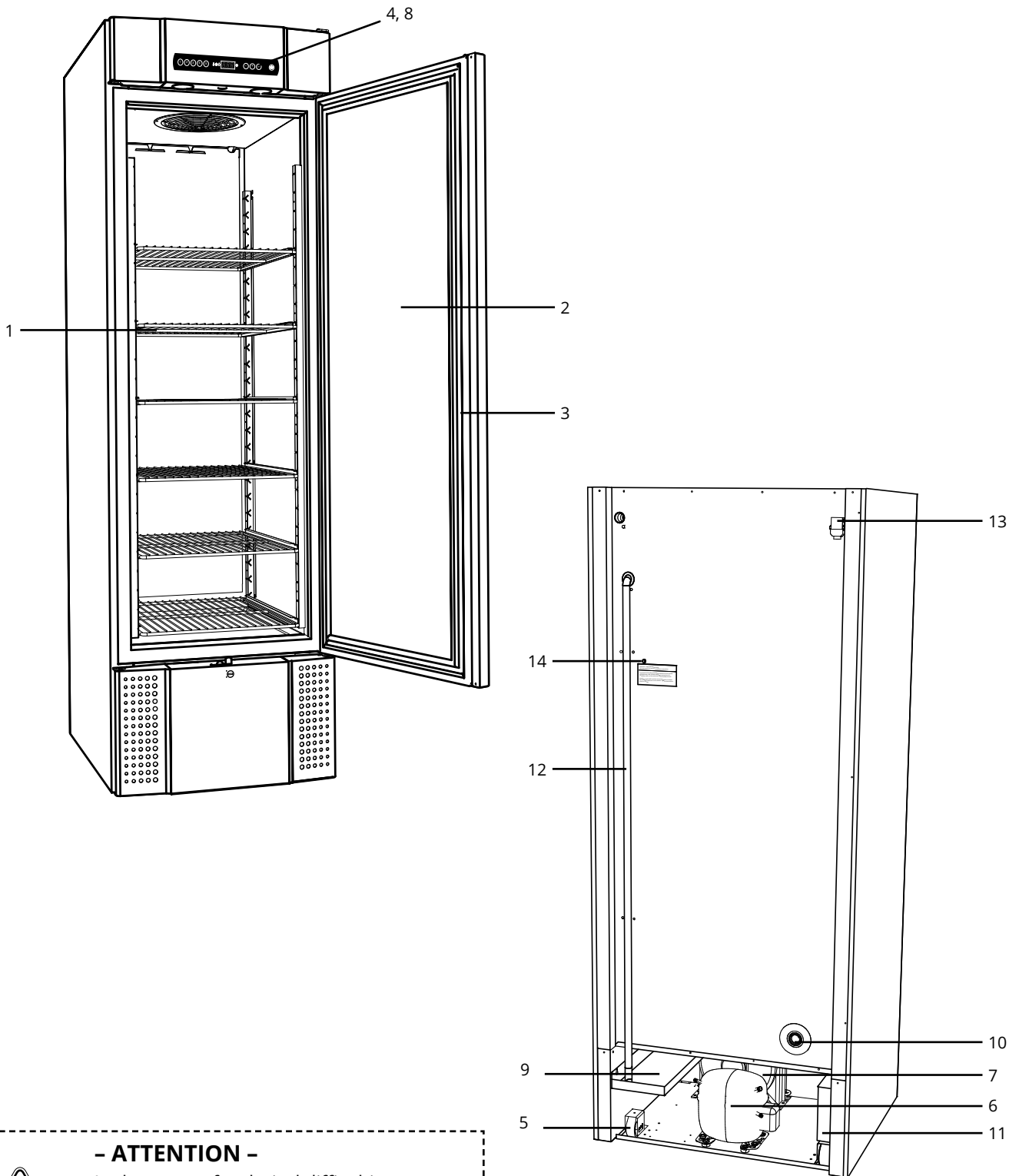

- ATTENTION -

In the event of technical difficulties or malfunction, always contact Gram BioLine technical support or a Gram BioLine authorised service partner.



- 1. Shelves and wall rails**
Ensure that the shelves are fixed correctly, before exerting load on them.
All shelves or drawers must be supported by at least two shelf or drawer supports each.
- 2. Door**
Ensure that the door is closed completely after use.
To minimise fluctuations in temperature, make the door openings as brief as possible.
- 3. Door gasket**
Ensure that the gasket is pliable and in good working order.
Keep the door gasket clean, find instructions in this instructions for use.
- 4. Digital display for controller**
Use the display to show the cabinet temperature and, to set the parameters described in this instructions for use.
- 5. Base of cabinet**
Ensure cabinets with legs are levelled properly and cabinets with castors are placed on a level surface and locked as mentioned in this instructions for use.
- 6. Compressor**
Ensure it is not dented or shows any other signs of damage.
- 7. Condenser and fan**
Ensure it is not dented or shows any other signs of damage.
- 8. Controller for refrigeration system**
Enclosure for controller, sensors and other parts that monitor and manage the refrigeration system.
Ensure it is not dented or shows any other signs of damage.
- 9. Re-evaporation tray**
Ensure it is not cracked or shows any other signs of damage.
It is recommended to clean it before applying power to the cabinet for the first time.
- 10. Access port**
Used to lead sensors and similar into the cabinet.
Ensure that the access port is sealed properly prior to start up.
- 11. Terminal box for voltage-free contact**
Used to connect to an external alarm system. Instructions for connection is found in this instructions for use.
Remember to set the external alarms (EAL).
- 12. Defrost water tube**
Outlet for the defrost water coming from the evaporator tray inside the cabinet.
Ensure it is not damaged or shows signs of damage.
- 13. Pressure equalisation valve**
Used to equalise pressure inside the cabinet when opening the door.
Ensure its not damaged or shows signs of damage.
- 14. Equipotential Bonding**
To ensure compliance with ATEX regulations EN 60079-14.
See installation section for specifications.



- ATTENTION -

If parts show signs of damage; do not use the cabinet and contact Gram BioLine or supplier for further aid.

Installation

Initial setup

This part of the instructions for use describes how to set up the cabinet.



- I-1*:** Due to safety and operating considerations, the cabinet must not be used outdoors.
- I-2*:** The cabinet should be installed in a dry and sufficiently ventilated area.
- I-3*:** To ensure efficient operation, the cabinet should not be installed in direct sunlight or close to heat sources.

I-4*: Ambient operating temperature range

BioPlus/BioMidi	Minimum ambient operating temperature	Maximum ambient operating temperature
RR with solid door	+10 °C	+43 °C
RR with glass door	+10 °C	+38 °C
ER with solid door	+10 °C	+43 °C
ER with glass door	+10 °C	+38 °C
RF with solid door	+10 °C	+43 °C
EF with solid door	+10 °C	+30 °C



The cabinet interior must not be exposed to corrosive atmospheres.



Ensure the use of appropriate personal protective equipment such as gloves, when handling the cabinet.



I-5*: Avoid placement of the cabinet in a chloric/acidic environment due to risk of corrosion.



I-6*: The cabinet is shipped with a protective film that should be removed prior to use.



I-7*: Clean the cabinet with a mild soap solution prior to use.



I-8*: The cabinet is only allowed to lay down for very short durations (for instance handling through a doorway). If the cabinet has been laying down, the cabinet must stand up-right for at least 24 hours prior to use. This enables oil in the compressors to flow back into place.

This part of the instructions for use describes how to adjust legs/castors on the cabinet (BioPlus).

I-9*: Cabinets equipped with legs should be levelled as shown in the illustration below.

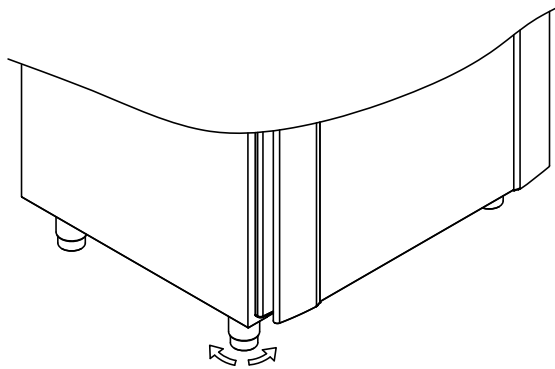

I-10-11*: For cabinets equipped with castors, the floor must be level to ensure stable positioning and safe use. When the cabinet is positioned, the two front casters should be locked.

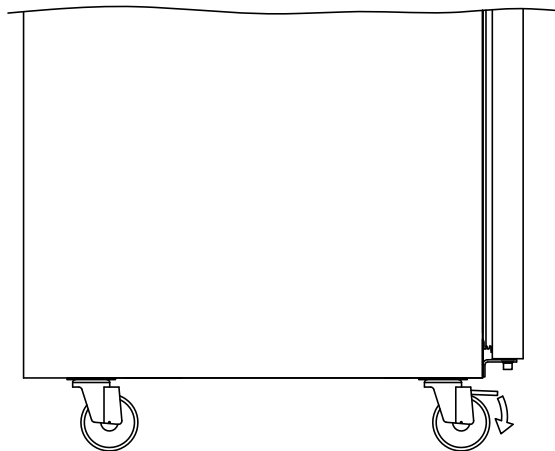

- WARNING -

POTENTIAL ELECTROSTATIC CHARGING HAZARD

Removing protective packaging and film may cause electrostatic discharge. Protective packaging and film shall not be removed in ATEX zones.

Anti tilt bracket



I-12*: Cabinets with drawers and/or glass door must be secured to a stable vertical surface, ensuring that the cabinet cannot tip over when the drawers are drawn to the outermost position, or the door is open. Brackets for securing is included.

Find the instructions for the tilt bracket below.

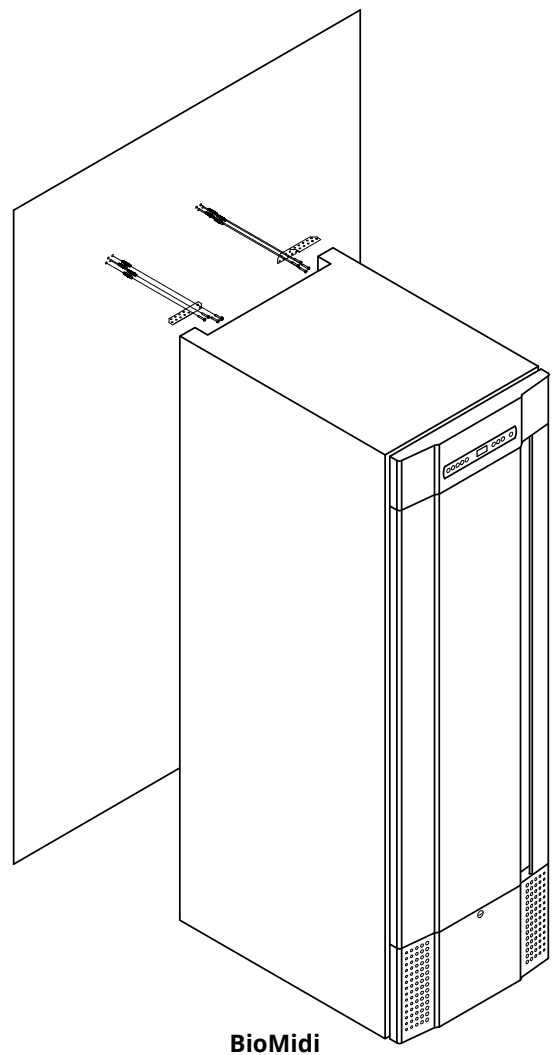
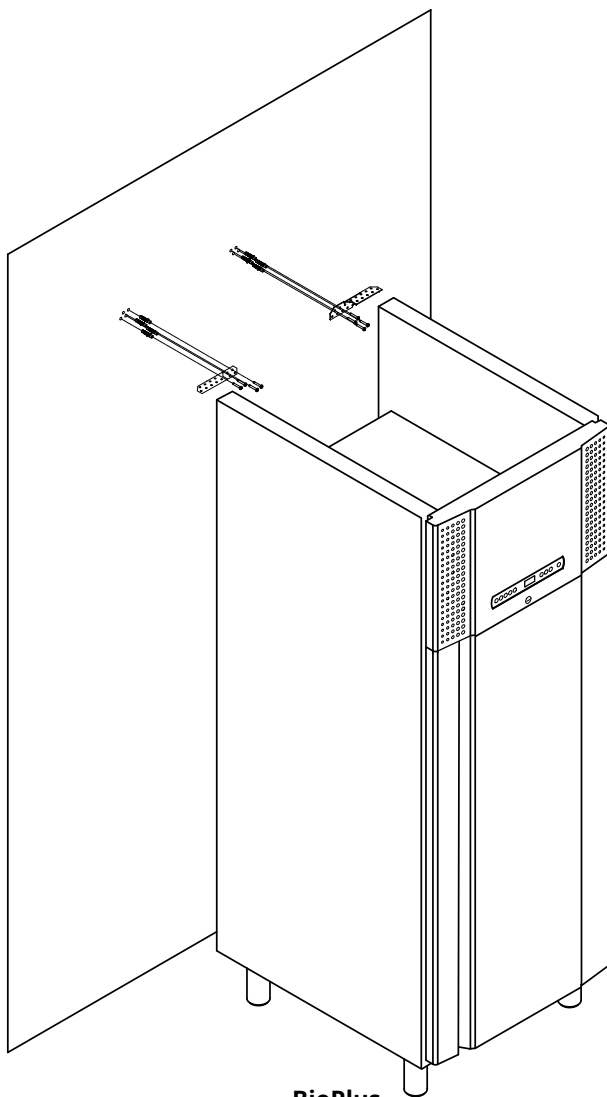

The tilt brackets must be fitted when installing the cabinet, ensuring that the users, surroundings and stored items are not damaged by the cabinet.

Surroundings

I-13*: The cabinet's back should be placed as close to the wall as possible. Maximum allowed distance between wall and cabinet is 75 mm.

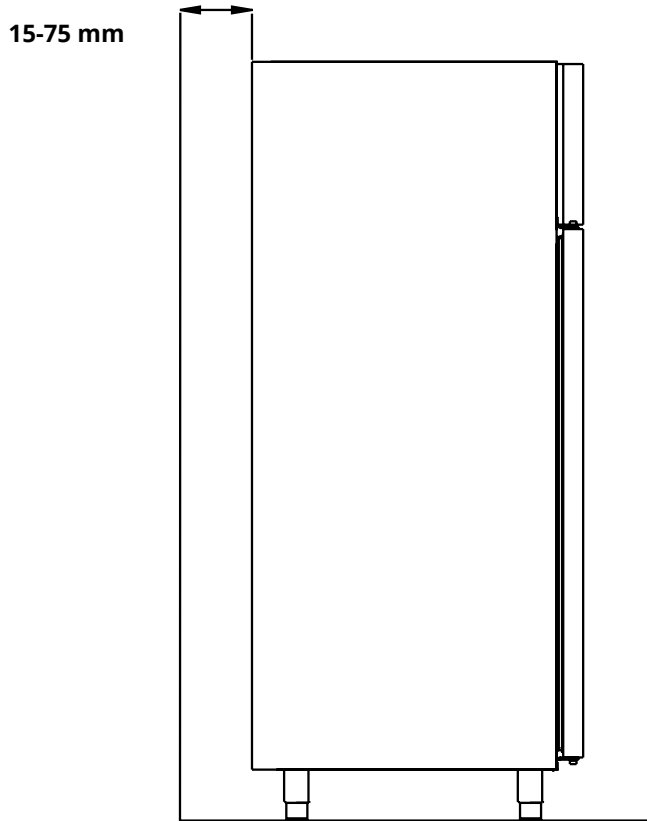

The cabinet is not suited for storing items that emit vapours which, either by themselves or in combination with other chemicals or water, may condensate and corrode the cabinet and its components.



All items in the cabinet that are not encapsulated, or wrapped, should be covered to reduce the risk of corrosion of the cabinet and its components.

- For Ex environments -
 Open containers inside the storage chamber may impact the ATEX zone classification.



I-14*: There must be at least a 30 mm gap between cabinets.

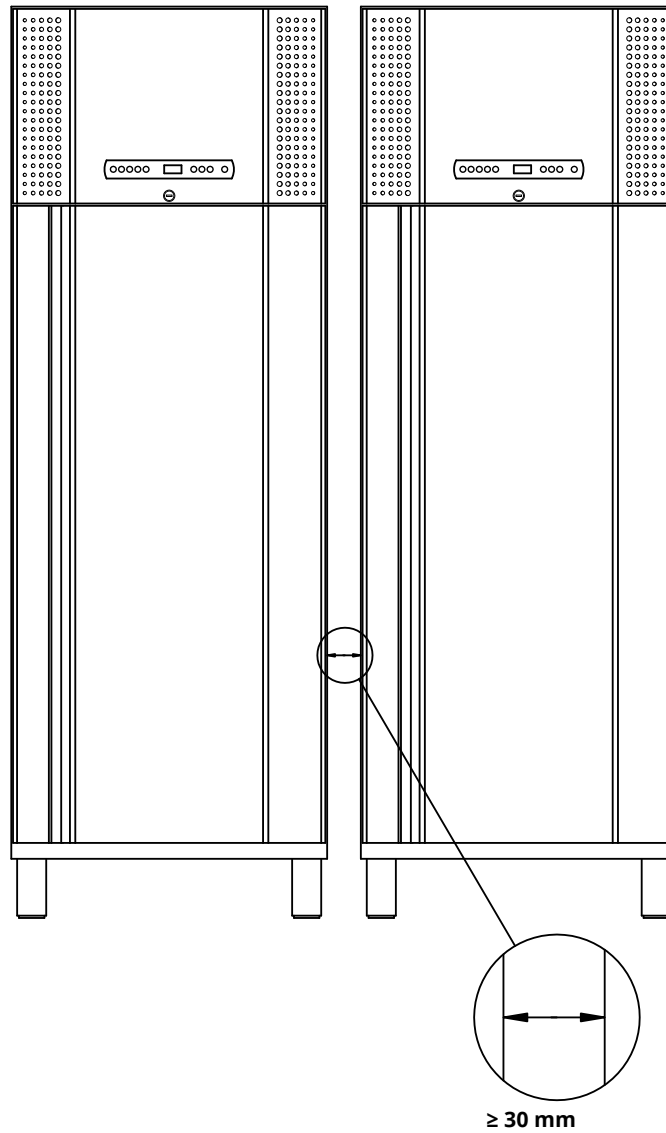

I-15*: Do not cover the upper part of the cabinet if it has a top mounted compressor.



I-16*: Do not use electrical appliances inside the cabinet.

Voltage-free contact

This part of the instructions for use covers the voltage-free contact.

I-17*: The illustration below shows the three connectors for the relay (used ex. in connecting to CTS or other external monitoring systems). The three connections, are respectively. Common, NO and NC.

The moment when voltage is applied the controller draws the relay, this makes it possible for the controller to respond to both high and low alarms, door alarms and power failures. Temperature alarms and door alarms must be configured in the external alarm settings (EAL) before they will activate the voltage-free contact. Find instructions on setting external alarms in the parameter settings section.

The wires that are connected in the connection block for the voltage-free contact, are secured in place by the press-fit plate that is pressed onto the block, thereby also preventing access to the electrical circuit.

Connection of the voltage-free contact should be done by a qualified installer.

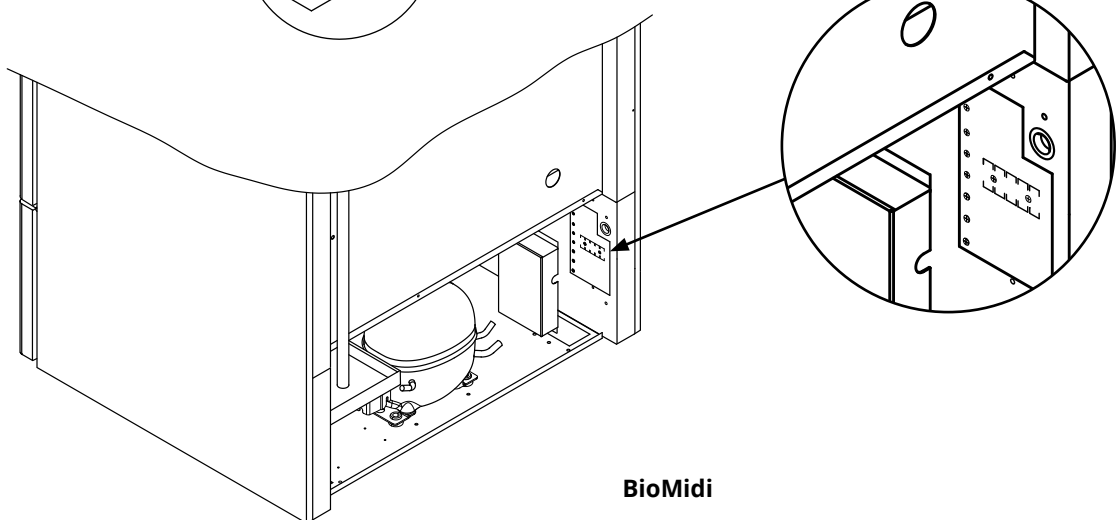
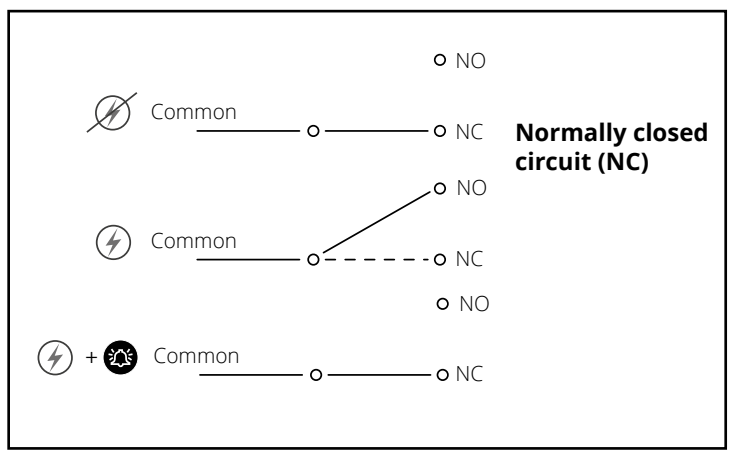
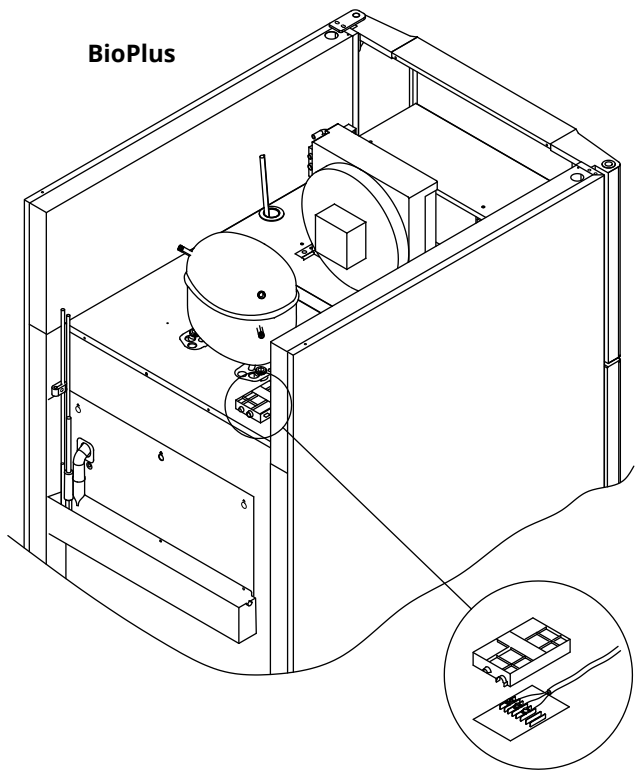

**) Paragraph designation (I-1, I-2 etc) refers to the IQ (Installation Qualification)*

Connection to power

Read the following part thoroughly before connecting the cabinet. Contact a qualified electrician if in doubt.

When setting up in an ordinary scenario that is not subject to regulations for EN 60079-15 zone 2:

The appliance may be connected in accordance with applicable local heavy current regulations.

Please note that there are special regulations for products that are in accordance with EN 60079-15 zone 2 and EN 60079-14: Explosive atmospheres – Electrical installations design, selection and erection.

The appliance has been manufactured in accordance with EN 60079-15: Electrical apparatus for explosive gas atmospheres – Part 15: Type of protection II 3G Ex nA nC nL IIB Tx Gc . Zone 2 is the applicable zone.

If the appliance is to be installed in a zone 2 environment, specialist personnel should perform the installation, or be consulted beforehand, in order to ensure that the appliance is installed in compliance with the guidelines currently contained in the standard.

I-19*: The cabinet is intended for connection to alternating current. The connection values for voltage (V) and frequency (Hz) are given on the type/number plate.

I-20-1*: The mains terminal is accessed via the preload cover as shown on the top of the control box. Unscrew the preload cover to access the mains supply terminal. Ensure that the preload cover is reinstalled after plugging in the power cord. The leaf spring in the preload cover must engage and preload the plug of the cord as shown in the illustrations on the following page. Ensure that the mains plug is seated completely in the terminal on the cabinet.

The appliance must be connected to the external power supply using a suitable device which mechanically prevents the plug and socket from being separated unintentionally.

I-21*: The connection must be labelled: **"DO NOT SEPARATE WHEN ENERGIZED"**

– ATTENTION –

Fuses and similar must never be removed or replaced while the appliance is connected to a power source. The electrical terminal box must never be opened while the appliance is connected to a power source.

The compressor's starting equipment must never be dismantled while the appliance is connected to a power source.

Whenever electrical components are dismantled or replaced, the appliance must be moved to an area in which there is no risk of ignition caused by the electrical components or gases contained in the appliance.

Never use the cabinet if the power plug is damaged. The cabinet should be examined by a Gram BioLine service technician in such cases.

When setting up in an ordinary scenario that is not subject to regulations for Zone 2: The appliance may be connected in accordance with applicable local heavy current regulations.

In both cases:

Use a three-wire plug, if the power outlet is intended for a three-wire plug, the lead in green/yellow insulation should be connected to the ground terminal.

Power must be connected via a wall socket. The wall socket should be easily accessible.

All earthing requirements stipulated by the local electricity authorities must be observed. The cabinet plug and wall socket should then have correct earthing. If in doubt, contact your local supplier or authorised electrician.

– For Ex environments –



Special conditions for safe use may apply to this product when installing in an EN 60079-14 environment. Please, see corresponding Ex certificate for specifications.

– Technical Support –

In the event of technical difficulties always contact Gram BioLine technical support or a Gram BioLine authorised service partner. Never dismantle the terminal box or any other electrical component.

Only applicable for BioPlus.

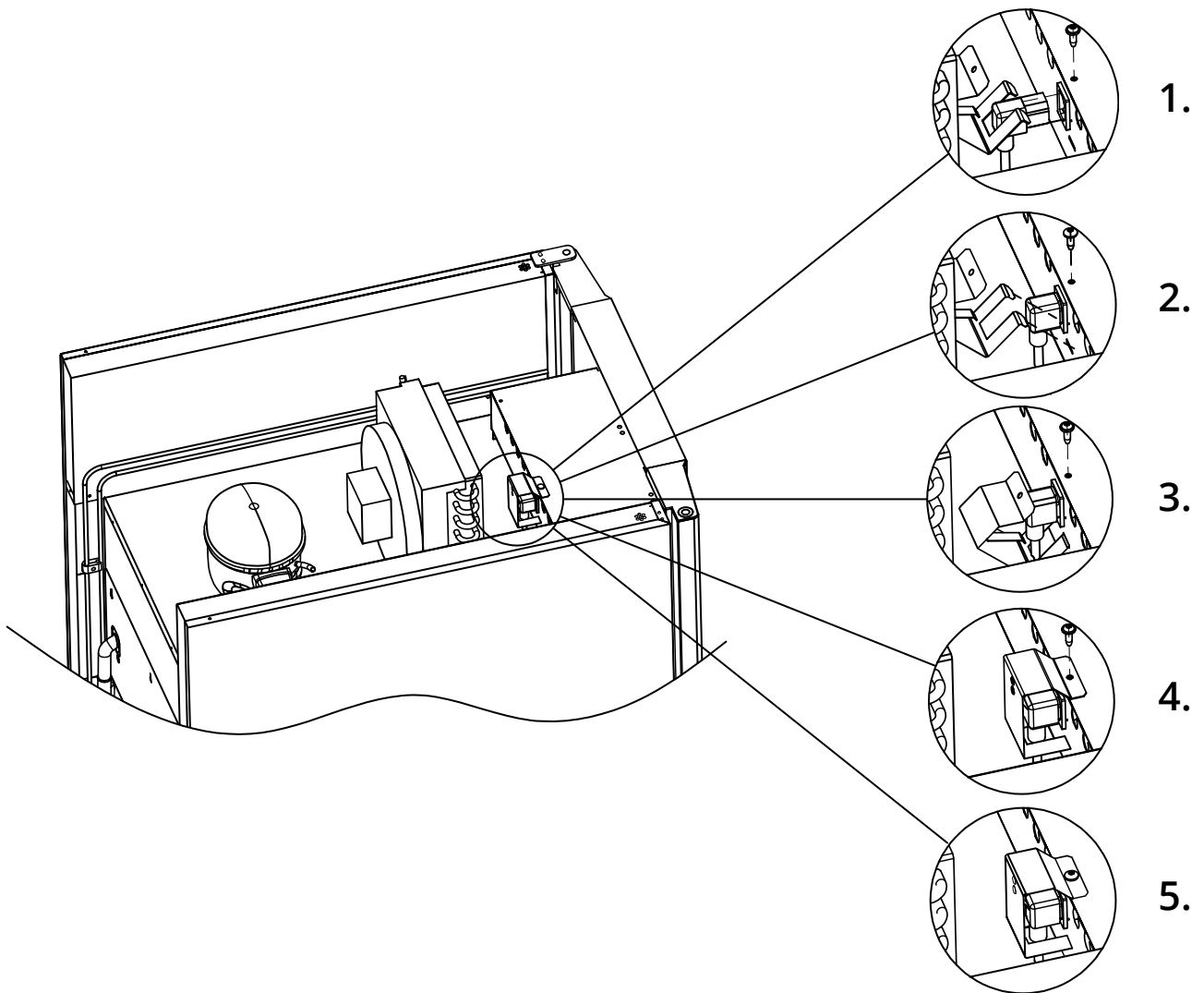

Equipotential bonding

This part of the instructions for use describes equipotential bonding.



I-22-1*: For installation in ATEX Cat. 3 Zone 2 areas, it is mandatory to have a equipotential bonding, it is not sufficient to use protective earth through the mains connection.

To secure equipotential bonding of the unit – The mounted external bonding conductor must be used in accordance with national installation requirements e.g. EN 60079-14.

- Mounting of the bonding conductor should be done according to the illustration below.
- Please find location for connection facilities on the back of the cabinet marked with: "Attention – Equipotential bonding".
- The bonding conductor should be at least 4 mm² guage thickness.
- Use a ring terminal to ensure adequate bonding.
- Use the supplied M5 machine screw and washer to attach the bonding conductor to the cabinet. Tighten the machine screw to 3.2 Nm.

Bonding of the cabinet is illustrated on this page.



- ATTENTION -

Please note: This location is the only manufacturer-approved location for equipotential bonding.

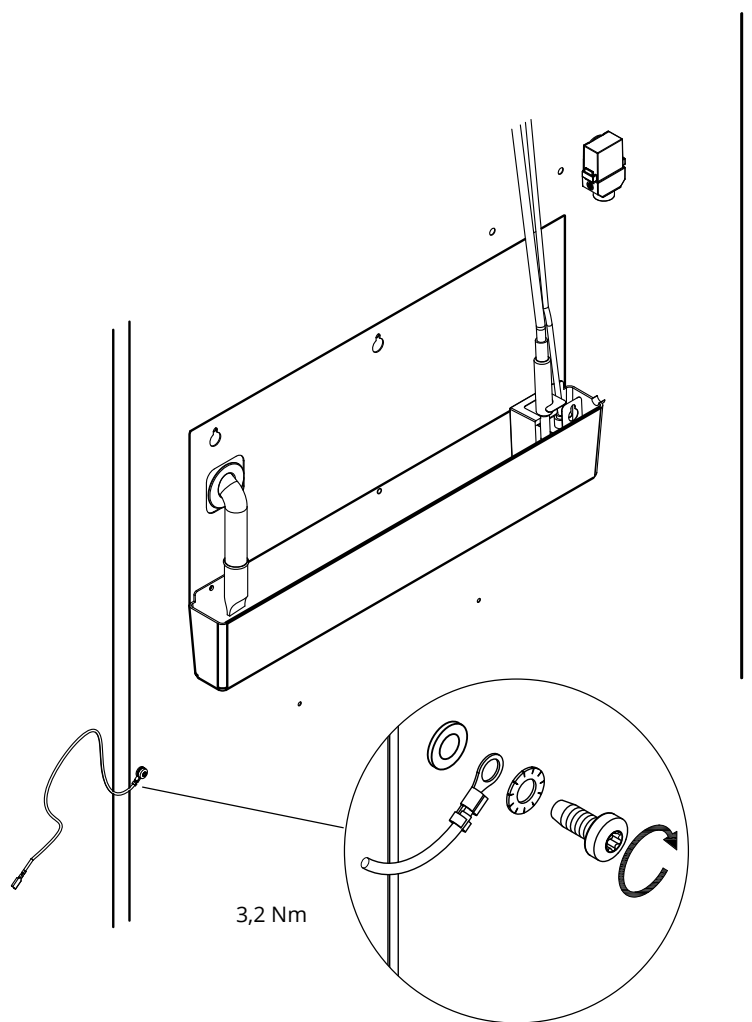

Options assembly

Introduction

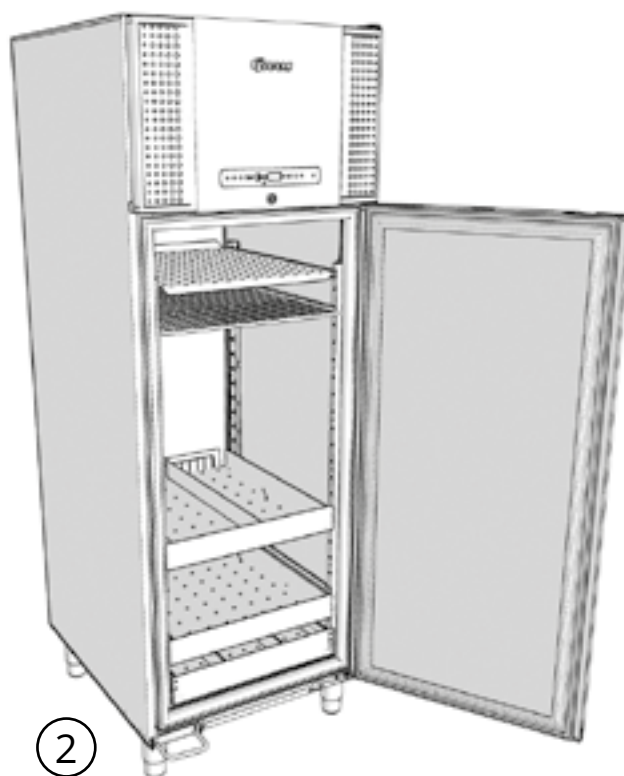
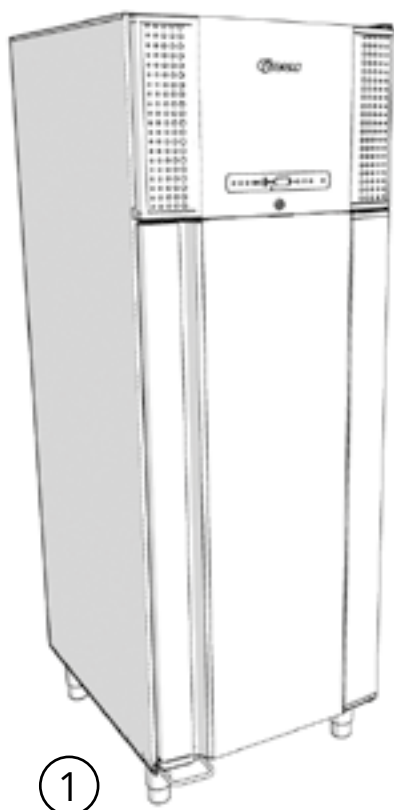

Shelf carriers

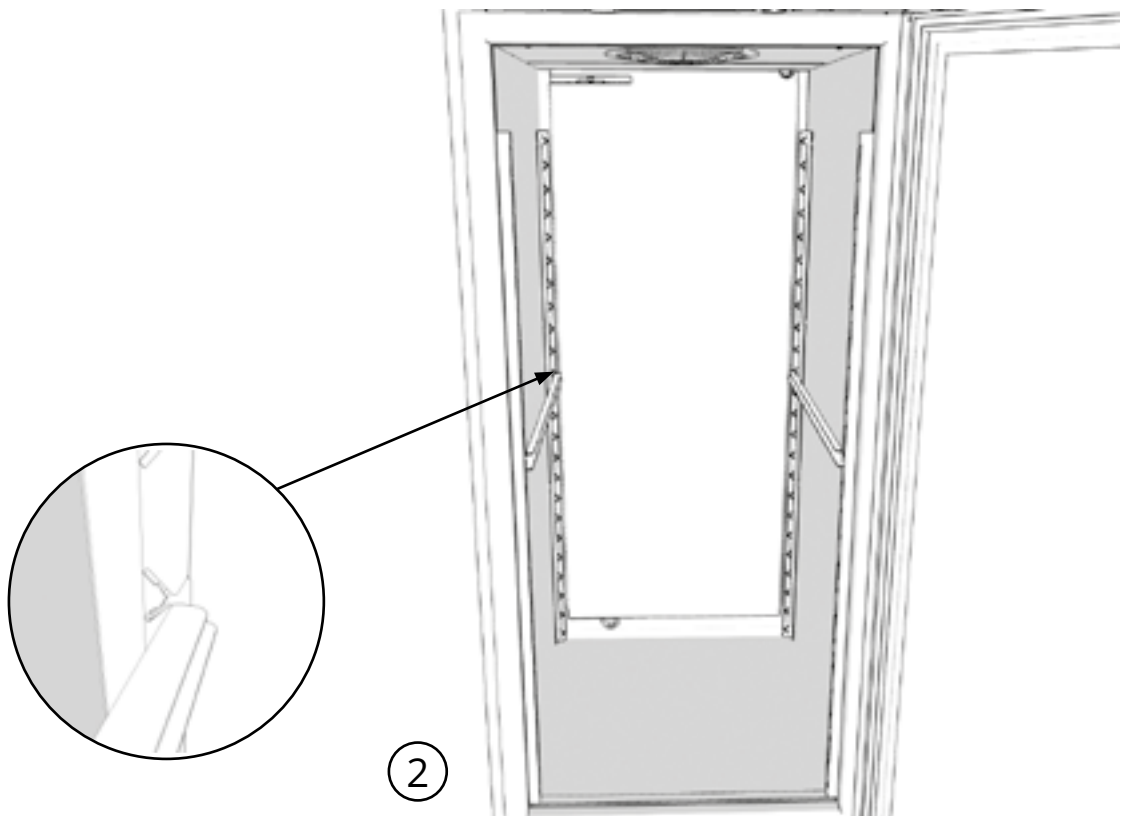
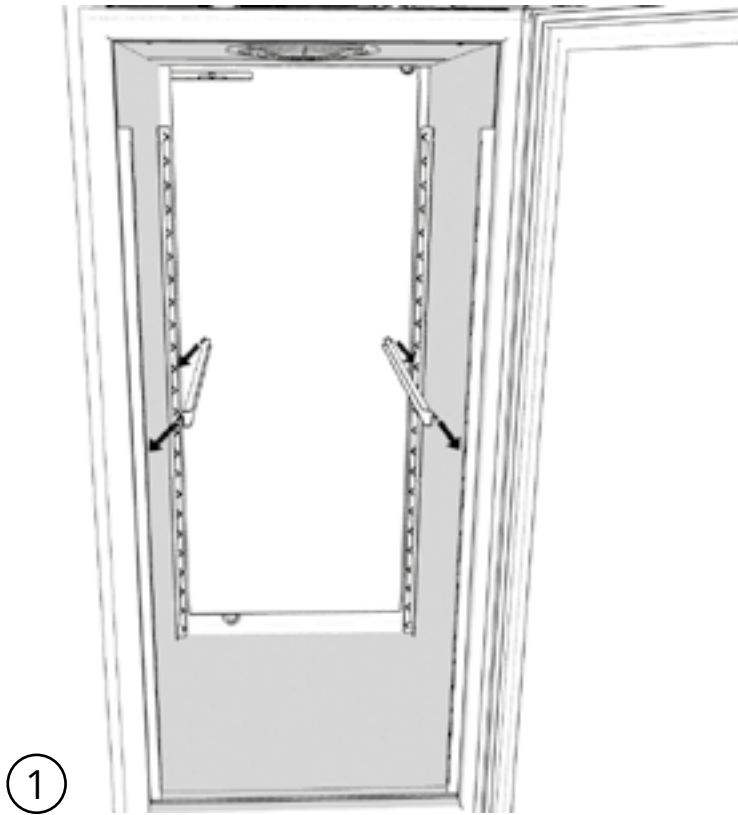

Perforated shelf

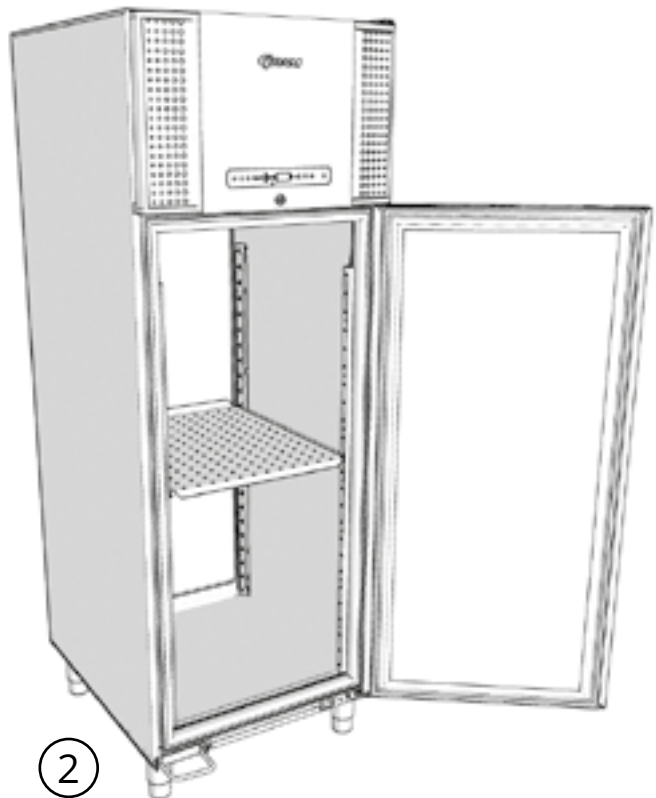
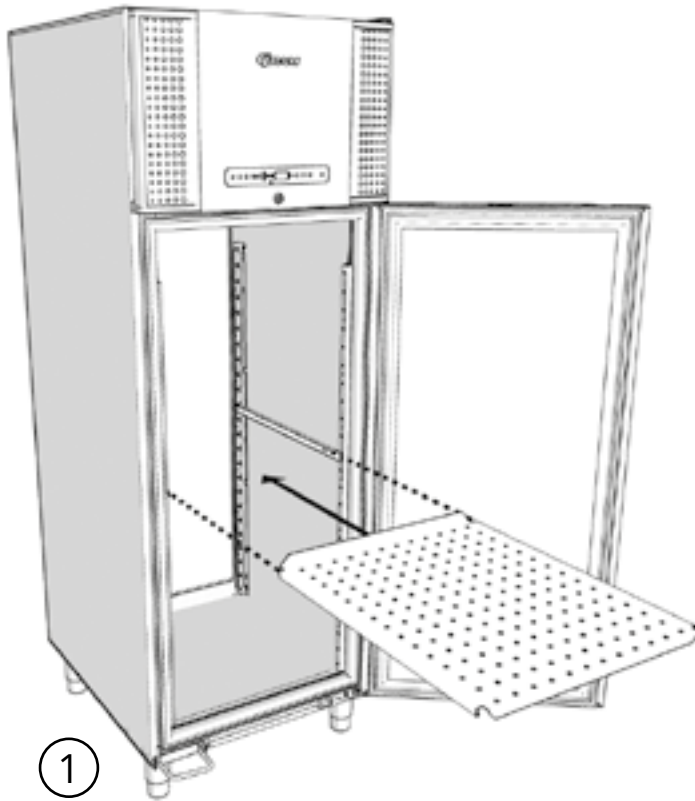

Wire shelf

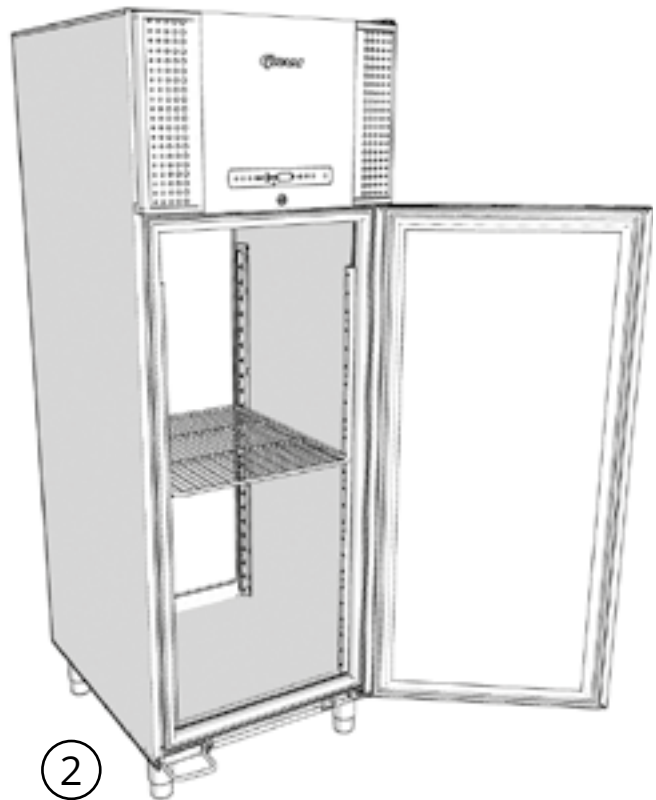
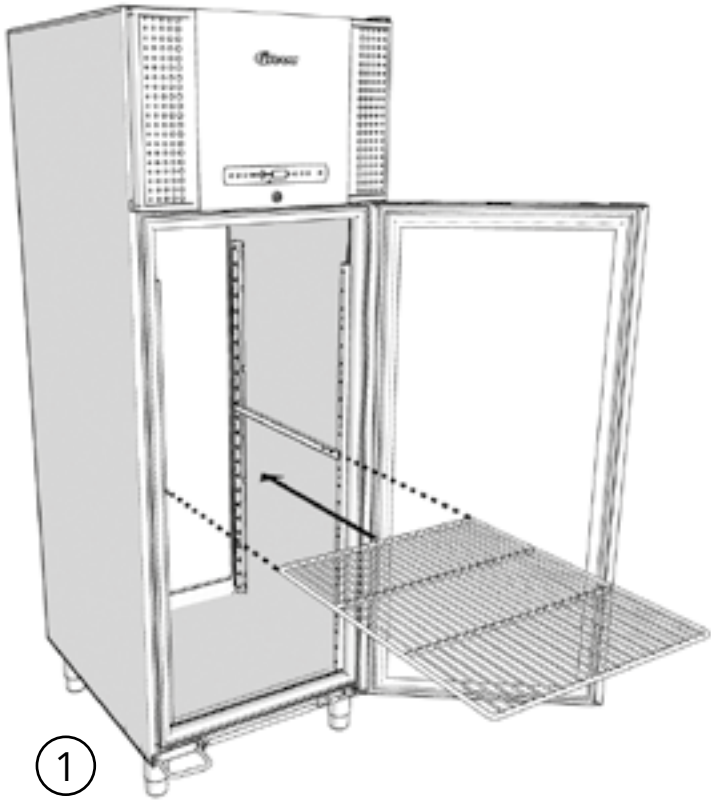

Carriers for aluminium drawer

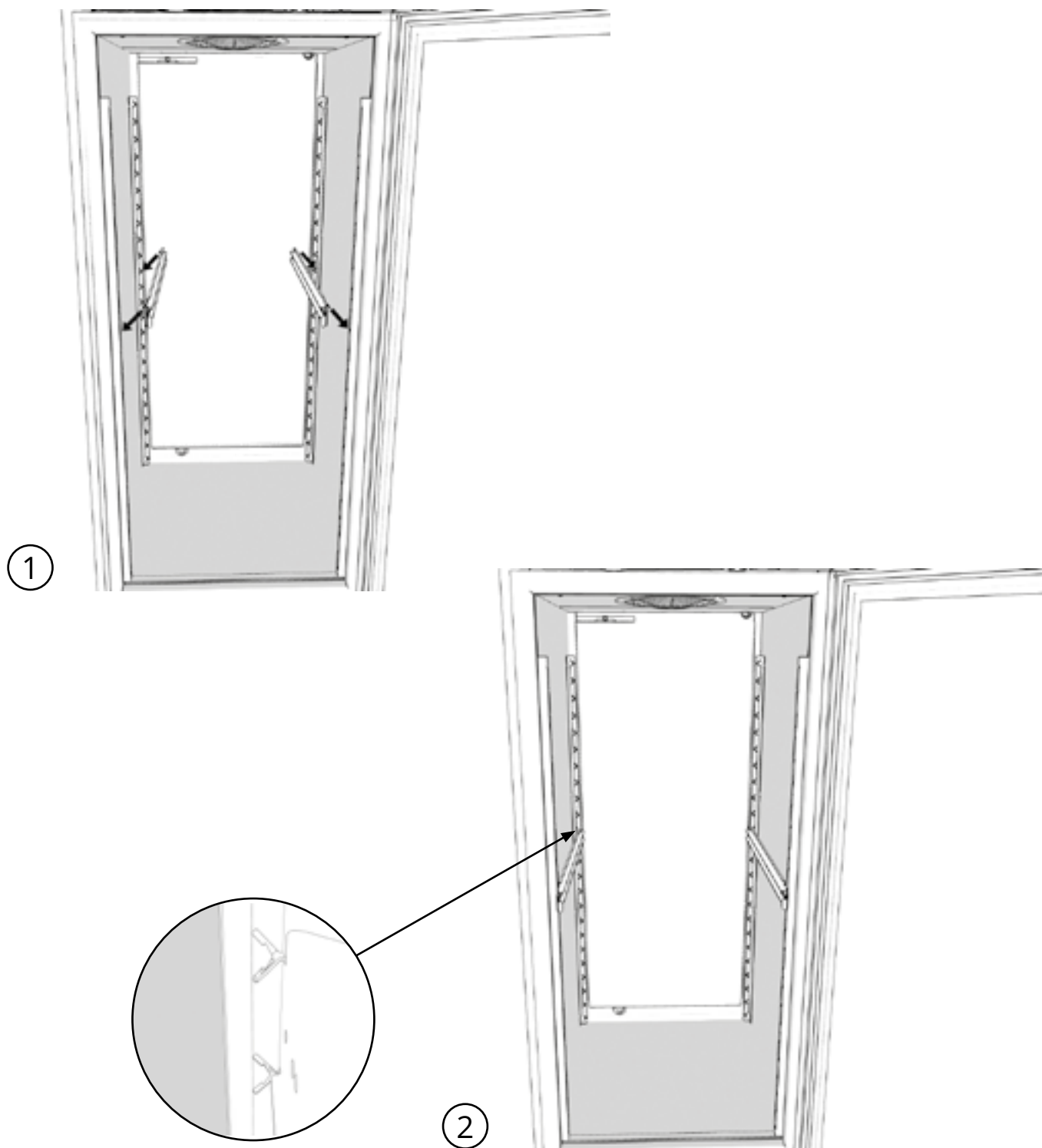

Aluminium drawer

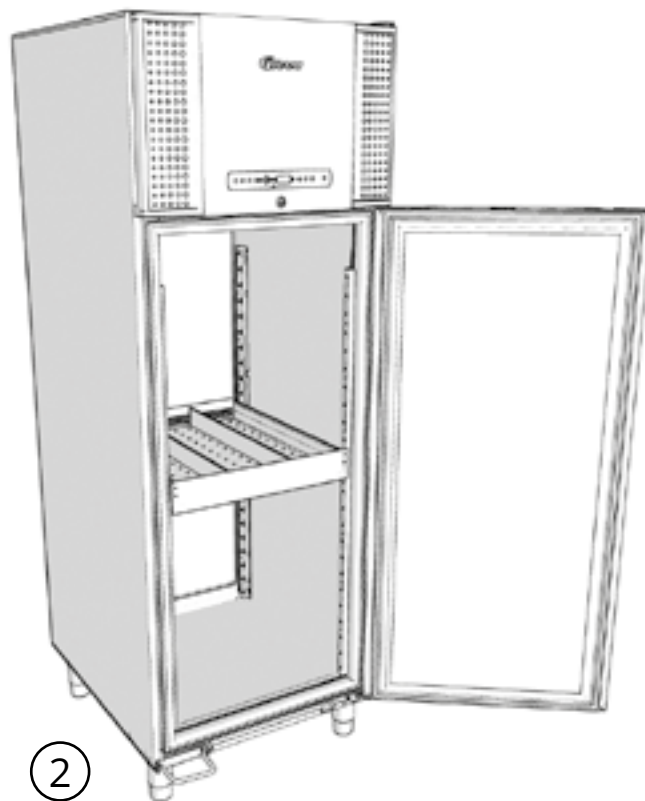
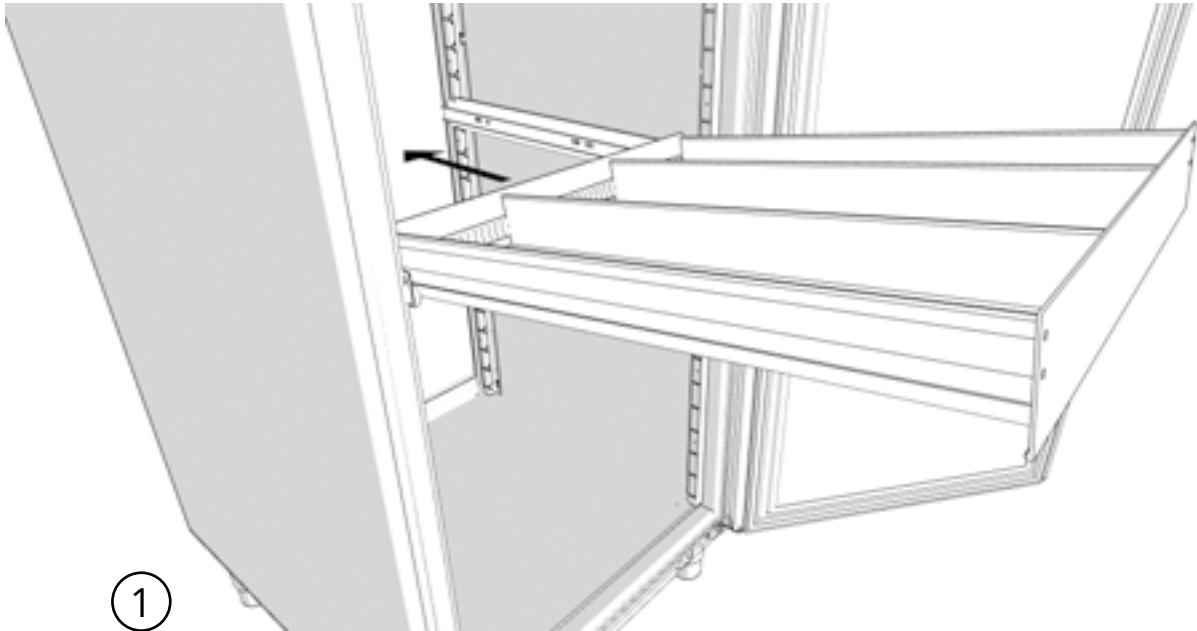

Carriers for 40 kg drawer

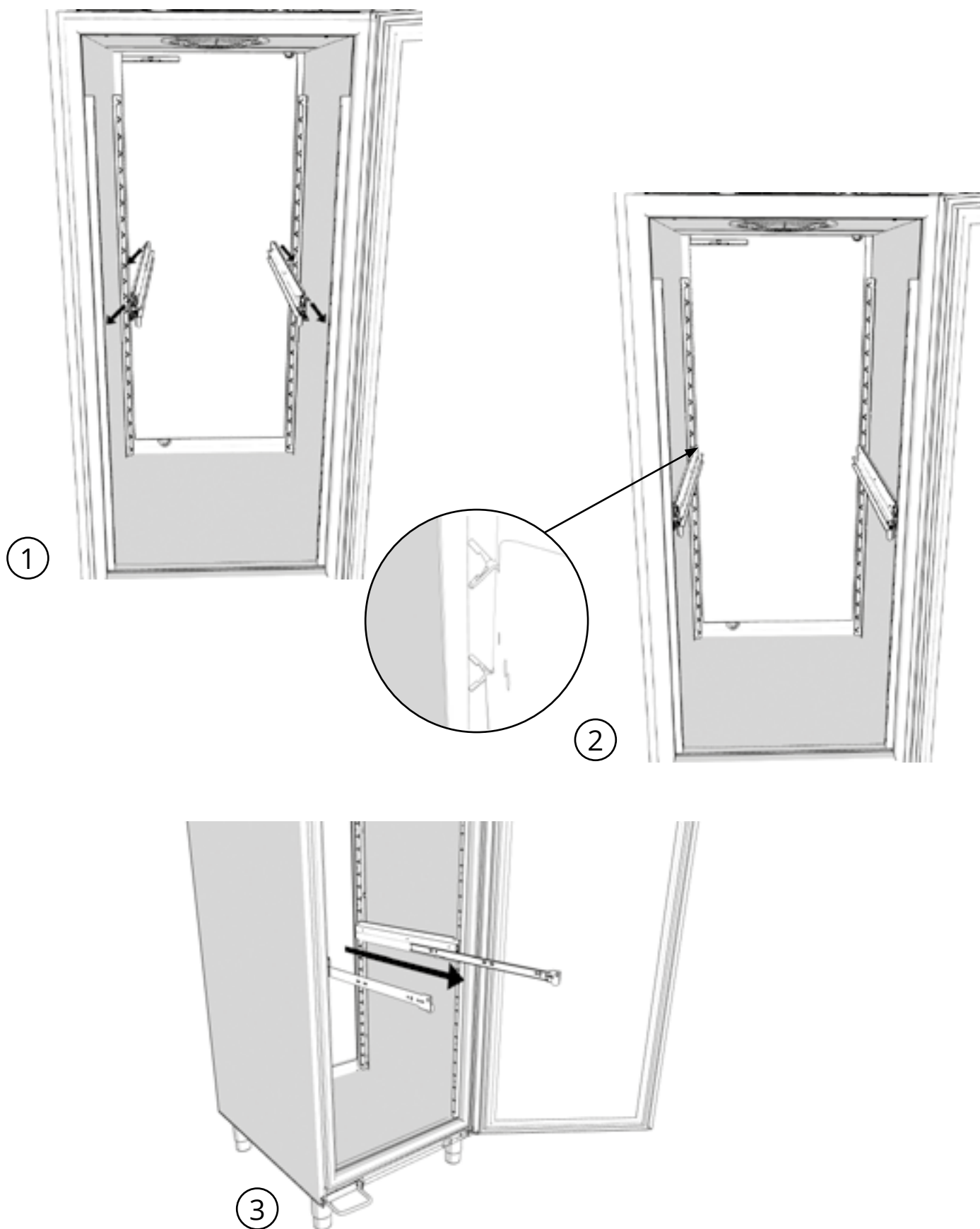

40 kg drawer

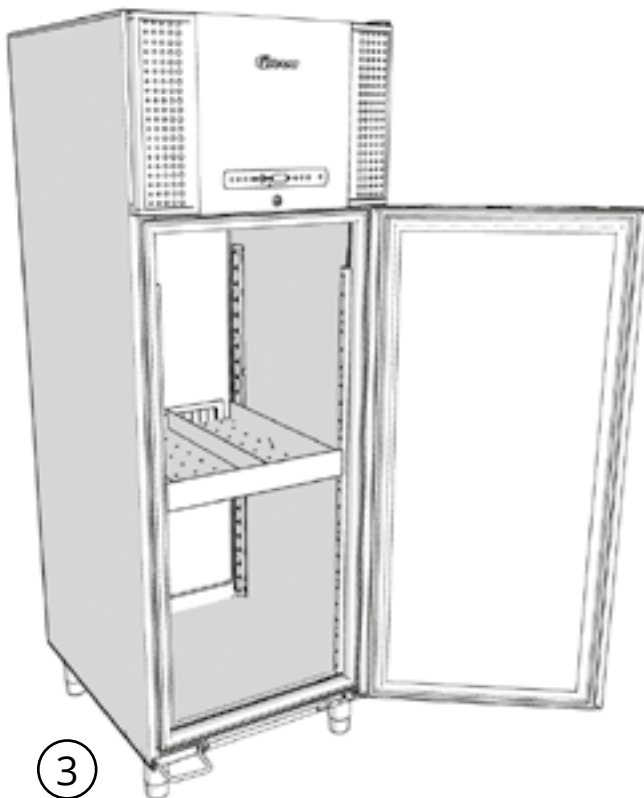
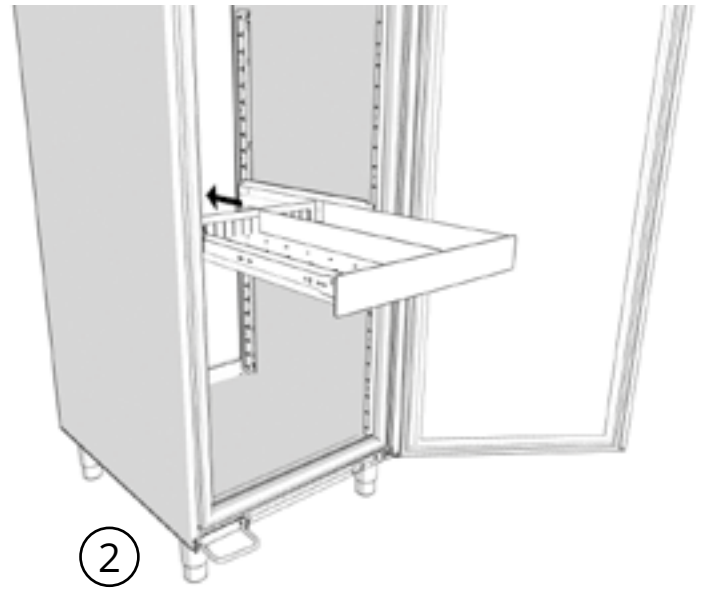
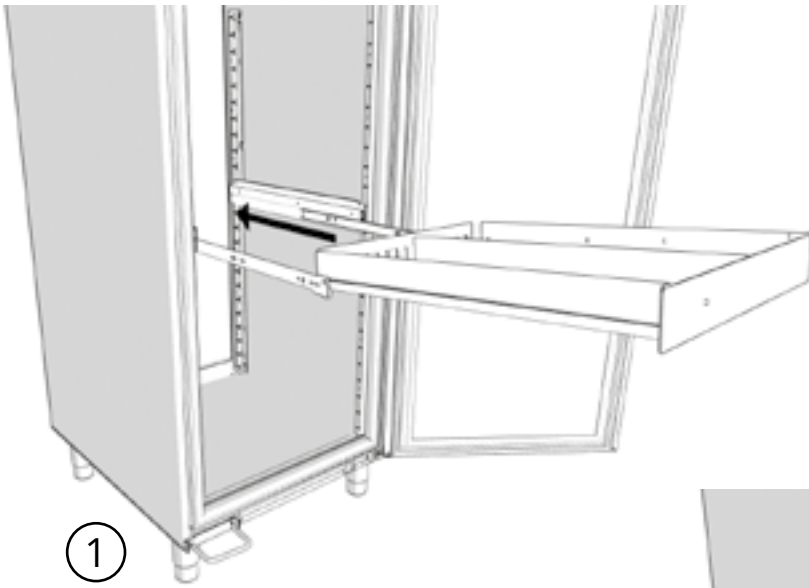

How to lock the shelf on a 40 kg drawer

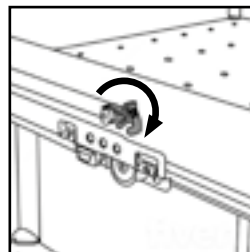
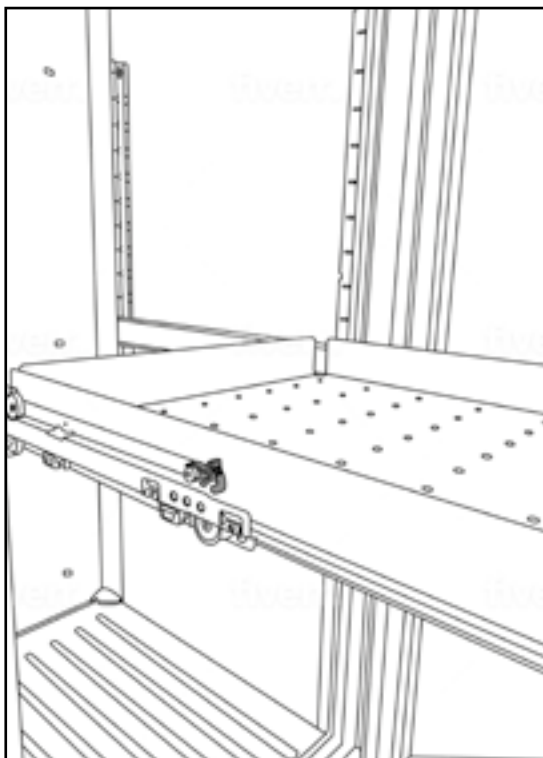
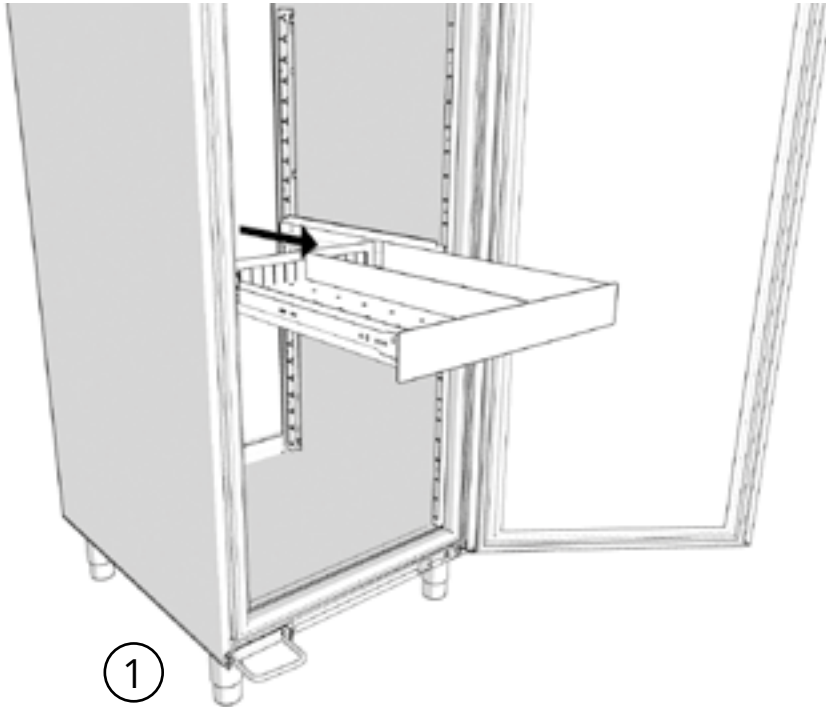

3 Push down

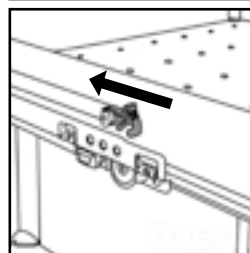

4 Push towards cabinet

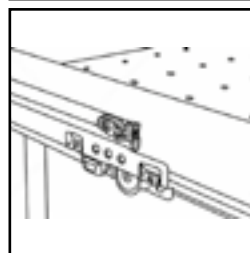

5 Locked shelf

2 Unlocked shelf

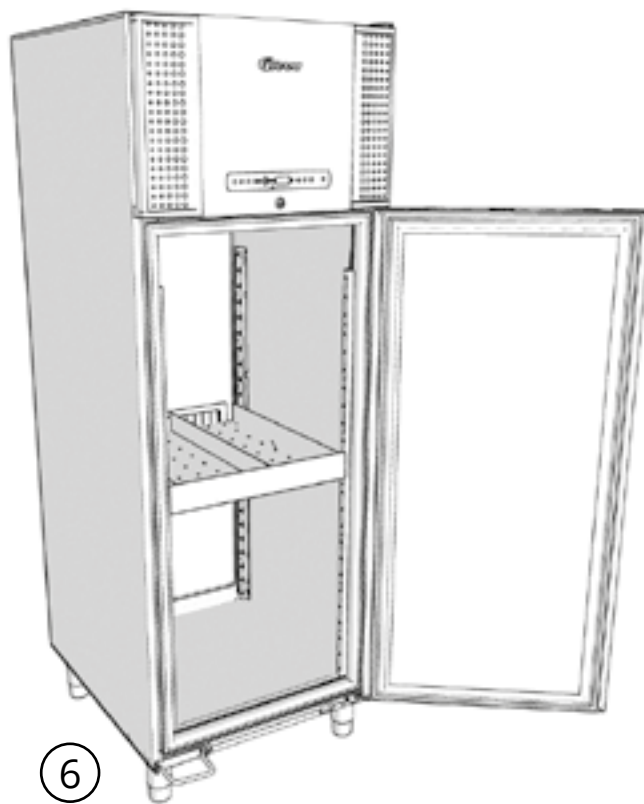

Carriers for 30 kg drawer

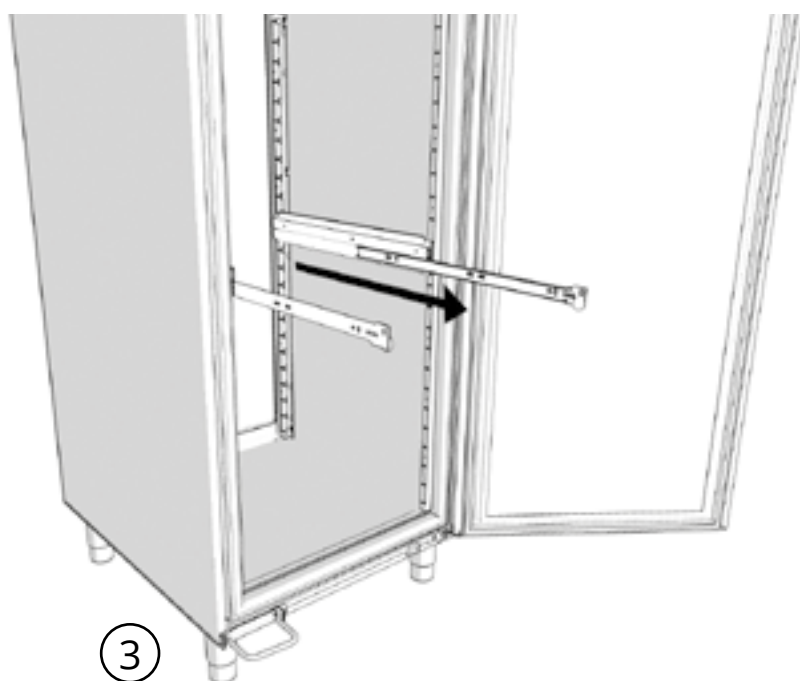
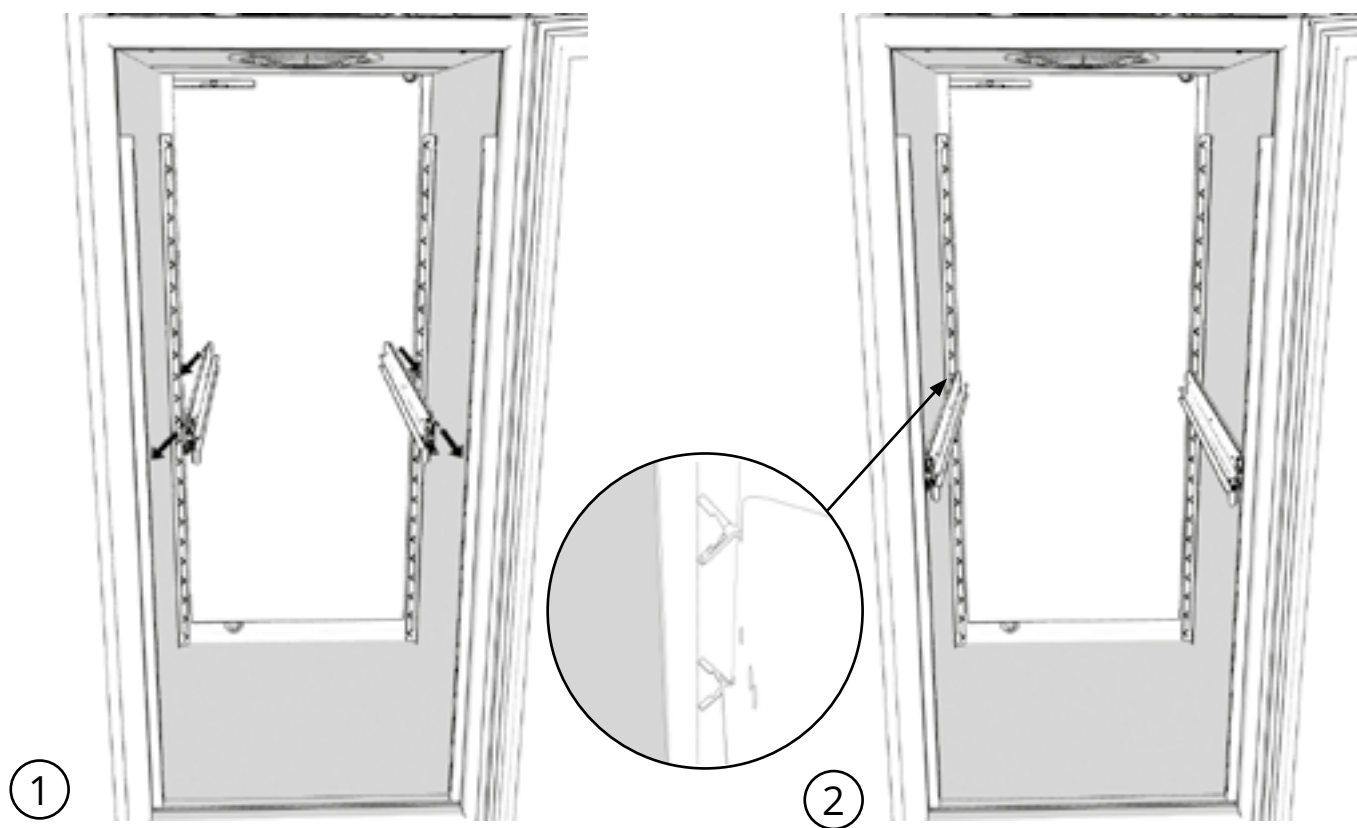

30 kg drawer

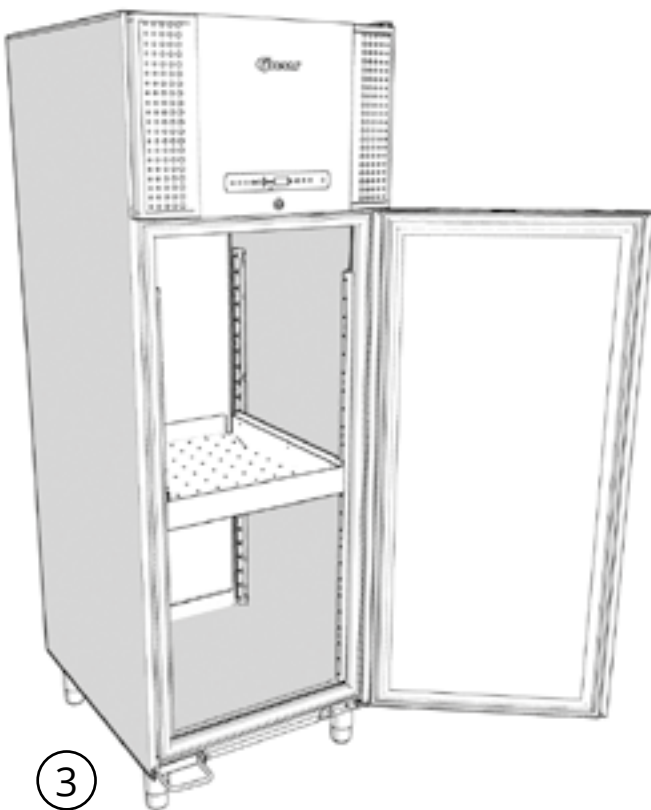
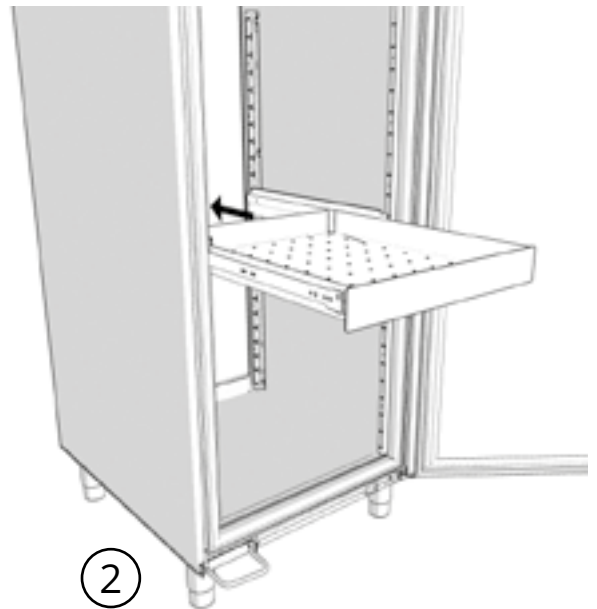
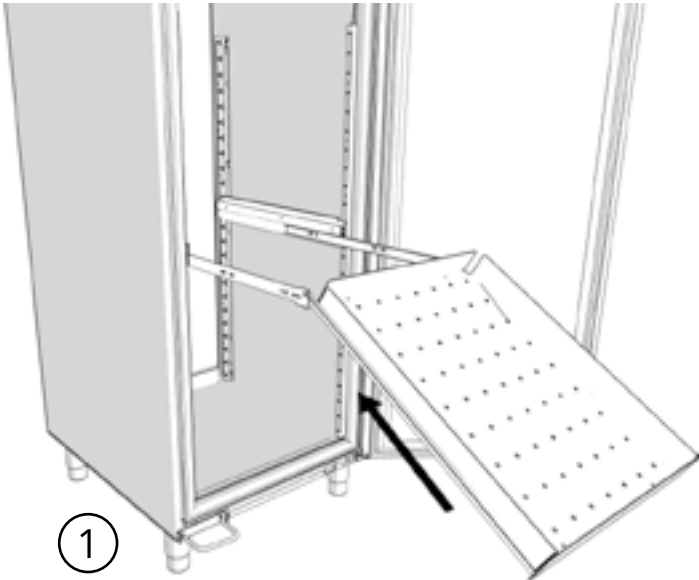

How to lock the 30 kg drawer

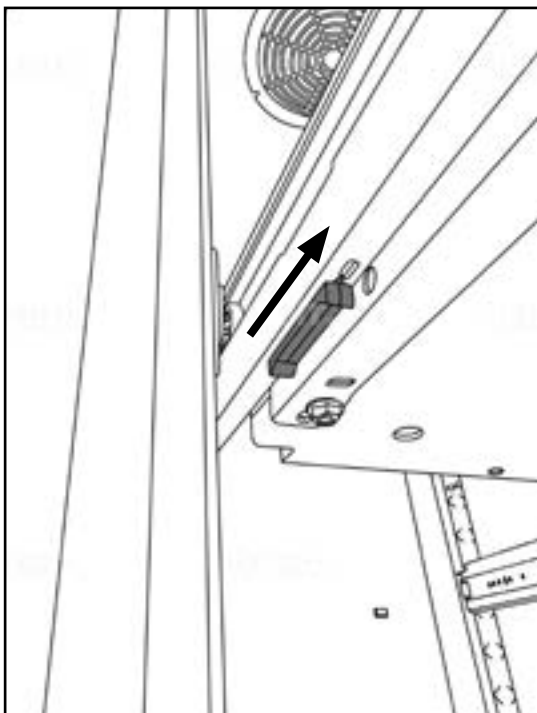
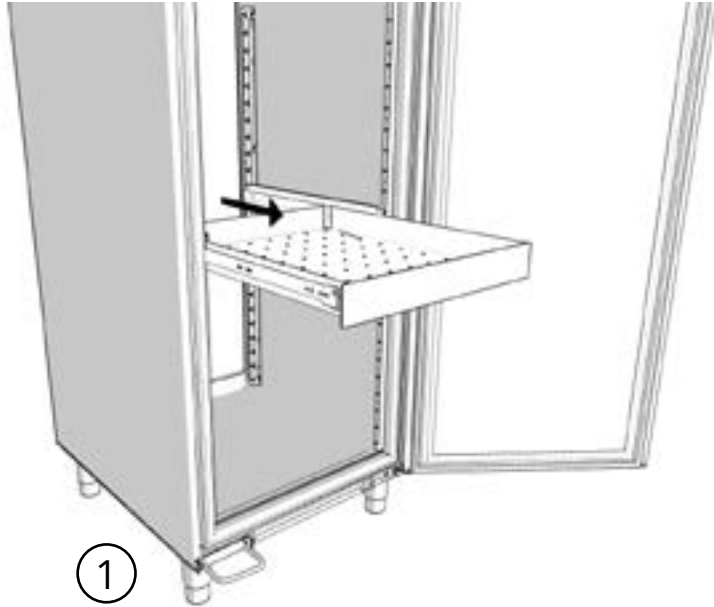

② Unlocked shelf

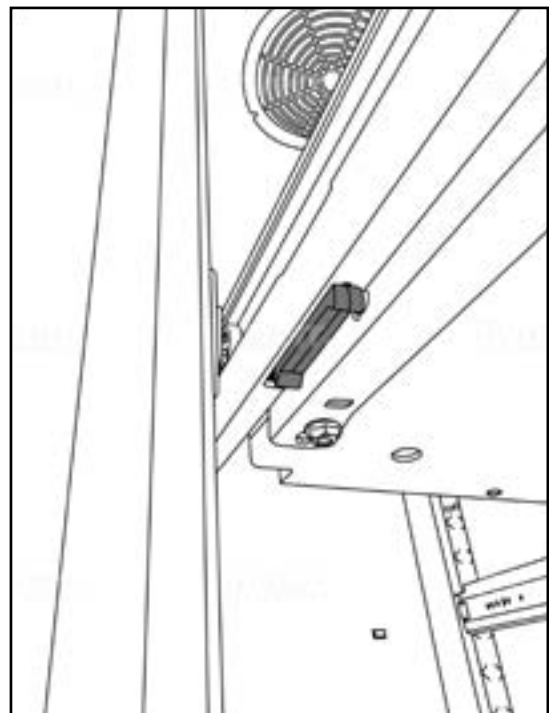

③ Locked shelf

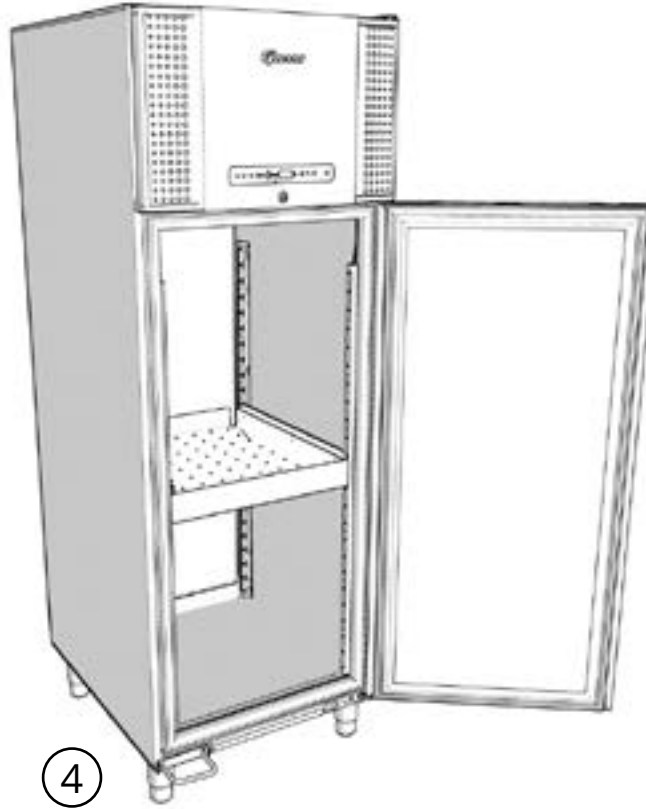

Start-up

The digital display

The digital display depicted below, shows the cabinet's temperature and indicates if the cabinet is connected to a power source. The following chapter explains the conventional operation of the cabinet and alarms for temperature, door etc.

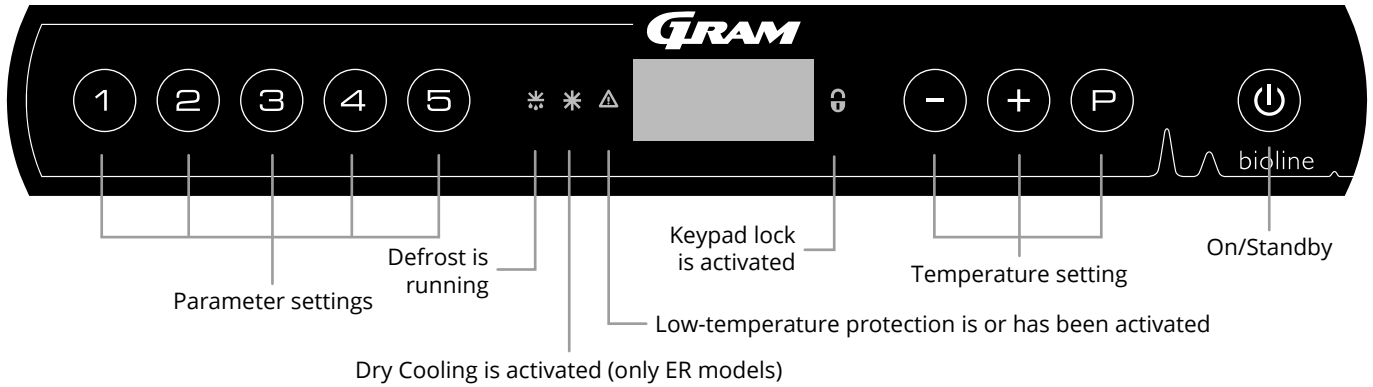

O-1*: On/Standby

Press to turn the cabinet on. Press for 6 seconds to switch to standby. The software version of the cabinet will be shown when turning the cabinet on, followed by the software variant and a display test.

The cabinet is ready when the temperature is displayed. The cabinet will automatically start a defrost-cycle when turned on, and terminate it again after a system check.

The cabinet will always commence operation when initially connected to a power supply. For instance after a power outage or when plugging the cabinet in for the first time.

- **Parameter setting**
Gives access to the cabinet's configurable parameters.
- **Defrost**
Defrost in progress
- **Dry cool**
Dry cool in progress (ER-models)
- **Keypad lock**
Keypad is locked, no access to functions or menus
- **Temperature setting**
Setting of temperature setpoint and navigation in the menus
- **On/Standby**
Turn the cabinet on or switch to standby, and navigation in the menus.

- ATTENTION -



Make sure the appliance is switched off at the socket before service is performed on electrical parts. It is not sufficient to switch the cabinet to standby on the , as current will persist in some electrical parts of the cabinet.

O-2*: Temperature setting

Temperature adjustments are done by holding and pressing either or . Confirm the settings by letting go of the keys.

- WARNING -



DO NOT OPEN, MAINTAIN OR SERVICE IN AN AREA WHEN AN EXPLOSIVE ATMOSPHERE IS PRESENT.

All-round introduction to navigating the menus

Beyond setting the temperature and On/Standby, , , and are used to navigate the menu and set the parameters of the cabinet.

The keys have the following functions in the menu:

- Open a menu step or confirm a set value in the parameter settings.
- Scroll upwards in a given menu or raise a given value in parameter settings (alarm setpoint for instance).
- Scroll downwards in a given menu or lower a given value in parameter settings.
- Go a step back in the menus.

- ATTENTION -



High and low temperature alarms set up in the cabinet's controller (including EAL alarms) must be accompanied.

Walkthrough of menu

The menu below gives a quick overview of the parameter settings for the cabinet.

User menu

Menu access	Ⓟ + ① → ↴	↵	→	
		dC*		Dry cooling [HO=Off/H1=On]
Local alarm settings	LAL	LhL	[° C]	Upper alarm limit. Code for activated alarm [A2]
		LLL	[° C]	Lower alarm limit. Code for activated alarm [A3]
		Lhd	[min.]	Delay of upper alarm limit
		LLd	[min.]	Delay of lower alarm limit
		dA	On/Off	Door alarm. Code for activated alarm [A1]. [1=On/0=Off]
		dAd	[min.]	Delay of door alarm
		bU	On/Off	Acoustic signal for alarm codes [A1], [A2] and [A3]. [1=On/0=Off]
External alarm settings	EAL	EhL	[° C]	Upper alarm limit. Code for activated alarm [A4]
		ELL	[° C]	Lower alarm limit. Code for activated alarm [A5]
		Ehd	[min.]	Delay of upper alarm limit
		ELd	[min.]	Delay of lower alarm limit
		dA	On/Off	Door alarm. Code for activated alarm [A1]. [1=On/0=Off]
		dAd	[min.]	Delay of external door alarm
		bU	On/Off	Acoustic signal for external alarm codes [A1], [A4], [A5]. [1=On/0=Off]
Offset of sensors	CAL	cA	[° K]	Calibration of A-sensor. Reference sensor for the refrigeration system
		cE	[° K]	Calibration of E-sensor. Reference sensor for the display and alarms
		cF	[° K]	Offset setting for F-sensor. Reference sensor for the low-temperature protection
Low-temperature protection	FP	ACt	On/off	Activation/deactivation of low-temperature protection
		tES	On	Test of low-temperature protection
		SEt	[° C]	Setting of the cut-off temperature for the low-temperature protection
		PrE	[...]	Read-out of the real-time temperature of the F-sensor
		ALL		Activation of escorted alarm limits. [FAS]=limits/[ESC]=follows setpoint
		dEF		Number of defrosts per 24 hours (4 is factory setting)
		dPS		Reference sensor for the display (A, E or F)

Other Shortcuts

Keys	Duration	Function
Ⓟ + Ⓜ	> 3 seconds	Start or stop a defrost
Ⓜ + ①	> 6 seconds	Activating/deactivating the keypad lock
Ⓟ	-	Shows the temperature setpoint value
+	-	Shows the highest registered temperature spike (since the last reset of the alarm history)
-	-	Shows the lowest registered temperature spike (since the last reset of the alarm history)
+ + -	> 3 seconds	Reset of the alarm history
Ⓟ + ① + ③	> 6 seconds	Reset of set parameters. Restores factory settings
Ⓟ + ①	> 3 seconds	Access to the user menu and alarm settings



* Only ER

Error codes

The following table covers the different error codes that might occur.

Display code	Explanation
- 0 -	Door is open.
[A1]	Door alarm "dAd" from LAL and/or EAL has been activated.
[A2]	Local upper alarm LhL is or has been activated.
[A3]	Local lower alarm LLL is or has been activated.
[A4]	External upper alarm EhL is or has been activated.
[A5]	External lower alarm ELL is or has been activated.
F1	Error on the main cabinet sensor. The refrigeration system will use an emergency program to make the cabinet run. Temperature stability will be affected. Service is required.
F2	Error on the evaporator sensor. Service is required.
F3	Error on the condenser sensor. Service is required.
F4	Error on condensor sensor 2. Service is required.
F5	Error on sensor for display and alarm. Service is required.
F7	F7 indicates that the temperature of the condenser is too high. Turn off the cabinet and check that the condenser is not covered by undesirable items, and insure that the condenser (and possibly filter) is clean. Service is required if the problem is not alleviated.

Acknowledge an acoustic alarm

- Cancelling a door alarm: [A1] Flashes in the display. Press  to cancel.
- Cancelling a temperature alarm: [A2, A3] Flashes in the display. Press  to cancel.









The display will continue to flash if the temperature is outside the alarm limits, and will continue so until the temperature has recovered.

Latching alarms: [A2], [A3], [A4], [A5]

Due to the potential implications of alarms, the red alarm triangle icon will turn on along with the corresponding alarm code will flash in the display. The alarm state will remain on until acknowledged by pressing .

Reading the alarm history – Example [A2]

[A2] Flashes in the display – This means that the temperature has exceeded the set value for the upper temperature limit, LhL.

- Press  to cancel the [A2]. The display continues to flash, indicating that there is information in the alarm history.
- Press , Htt (High temperature time) is shown, press  to see for how long the temperature was above the set alarm limit.
- Press  to return to Htt. Press  to reach Ht (Highest temperature).
- Press  to read the highest recorded temperature during Htt. Press  to return to Ht and press  again to leave the alarm history function.

The procedure for reading an [A3] alarm is identical, apart from entering the alarm history with . When reading out temperatures below set limits, the parameters are Ltt and Lt.

A flashing display with no alarm codes indicates that the alarm codes have been cancelled, but the alarm history contains information.

Dry cool

The following part covers activation/deactivation of the dry cool feature (only applicable to ER models).

dC – Setting the dry cool feature

- ↳ Press and hold P + 1 until dC is shown in the display
- ↳ Press P to choose “dC”
- ↳ Press + or - to choose between [H1= Off] [H0=On]
- ↳ Press P to confirm
- ↳ Leave the user menu by pressing ⏏ , press several times until the cabinet’s temperature is shown in the display.

Please note: Dry cool feature reduces the relative humidity in the cabinet, but does not control it. Activation of the dry cool feature can cause greater fluctuations in the cabinet’s temperature during defrost.

Local alarm settings

Local high alarm Local low alarm

The following part covers the setting of the upper and lower temperature alarm limits.

O-3*: LhL – Setting the upper alarm limit [° C]

- ↳ Press and hold (P) + (1) for more than 3 seconds
- ↳ Press (+) to proceed to "LAL"
- ↳ Press (P) to select "LAL". "LhL" is now shown in the display
- ↳ Press (P) to select "LhL". The upper alarm limit is now shown in the display
- ↳ Press (+) or (-) to set the desired value for the upper alarm limit
- ↳ Press (P) to confirm the set value
 - The upper alarm limit is now set, proceed to other parameters by pressing (⏪), then navigate by using (+) or (-)
- ↳ Leave the user menu by pressing (⏪) several times until the cabinet's temperature is shown in the display

O-4*: LLL – Setting the lower alarm limit [° C]

- ↳ Press and hold (P) + (1) for more than 3 seconds
- ↳ Press (+) to proceed to "LAL"
- ↳ Press (P) to select "LAL". "LhL" is now shown in the display
- ↳ Press (+) to proceed to "LLL"
- ↳ Press (P) to select "LLL". The lower alarm limit is now shown in the display
- ↳ Press (+) or (-) to set the desired value for the lower alarm limit
- ↳ Press (P) to confirm the set value
 - The lower alarm limit is now set, proceed to other parameters by pressing (⏪), then navigate by using (+) or (-)
- ↳ Leave the user menu by pressing (⏪) several times until the cabinet's temperature is shown in the display



- ATTENTION -

High and low temperature alarms set up in the cabinet's controller (including EAL alarms) must be accompanied by additional redundant independent external alarms to ensure maximum item safety.

Local high alarm delay

Local low alarm delay

The following part covers the setting of the delay for the local upper and lower temperature alarm limits.

O-5*: Lhd – Setting the delay of the local upper alarm limit [min.]

- ↳ Press and hold **(P)** + **(1)** for more than 3 seconds
- ↳ Press **(+)** to proceed to “LAL”
- ↳ Press **(P)** to select “LAL”. “LhL” is now shown in the display
- ↳ Press **(+)** several times until “Lhd” is shown in the display
- ↳ Press **(P)** to select “Lhd”. The delay of the upper alarm limit is now shown in the display
- ↳ Press **(+)** or **(-)** to set the desired value for the delay of the upper alarm limit
- ↳ Press **(P)** to confirm the set value
 - The delay of the upper alarm limit is now set, proceed to other parameters by pressing **(⏏)**, then navigate by using **(+)** or **(-)**
- ↳ Leave the user menu by pressing **(⏏)** several times until the cabinet’s temperature is shown in the display

O-6*: LLd – Setting the delay of the local lower alarm limit [min.]

- ↳ Press and hold **(P)** + **(1)** for more than 3 seconds
- ↳ Press **(+)** to proceed to “LAL”
- ↳ Press **(P)** to select “LAL”. “LhL” is now shown in the display
- ↳ Press **(+)** several times until “LLd” is shown in the display
- ↳ Press **(P)** to select “LLd”. The delay of the lower alarm limit is now shown in the display
- ↳ Press **(+)** or **(-)** to set the desired value for the delay of the lower alarm limit
- ↳ Press **(P)** to confirm the set value
 - The delay of the lower alarm limit is now set, proceed to other parameters by pressing **(⏏)**, then navigate by using **(+)** or **(-)**
- ↳ Leave the user menu by pressing **(⏏)** several times until the cabinet’s temperature is shown in the display



- ATTENTION -

High and low temperature alarms set up in the cabinet’s controller (including EAL alarms) must be accompanied by additional redundant independent external alarms to ensure maximum item safety.

On/Off local door alarm

Delay for local door alarm

The following part covers the setting of the door alarm and the delay of the door alarm.

O-7*: dA – Activate/deactivate of local door alarm

- ↳ Press and hold (P) + (1) for more than 3 seconds
- ↳ Press (+) to proceed to "LAL"
- ↳ Press (P) to select "LAL". "LhL" is now shown in the display
- ↳ Press (+) several times until "dA" is shown in the display
- ↳ Press (P) to select "dA"
- ↳ Press (+) or (-) to activate/deactivate the local door alarm [1 = activated/0 = deactivated]
- ↳ Press (P) to confirm the set value
 - The local door alarm is now configured, proceed to other parameters by pressing (⏪), then navigate by using (+) or (-)
- ↳ Leave the user menu by pressing (⏪) several times until the cabinet's temperature is shown in the display

O-8*: dAd – Setting the delay of the local door alarm [min.]

- ↳ Press and hold (P) + (1) for more than 3 seconds
- ↳ Press (+) to proceed to "LAL"
- ↳ Press (P) to select "LAL". "LhL" is now shown in the display
- ↳ Press (+) several times until "dAd" is shown in the display
- ↳ Press (P) to select "dAd". The delay of the local door alarm is now shown in the display
- ↳ Press (+) or (-) to set the desired value for the delay of the local door alarm
- ↳ Press (P) to confirm the set value
 - The delay of the local door alarm is now configured, proceed to other parameters by pressing (⏪), then navigate by using (+) or (-)
- ↳ Leave the user menu by pressing (⏪) several times until the cabinet's temperature is shown in the display



- ATTENTION -

High and low temperature alarms set up in the cabinet's controller (including EAL alarms) must be accompanied by additional redundant independent external alarms to ensure maximum item safety.

Buzzer – Acoustic local alarms

The following part covers the setting of the acoustic local alarms.

O-9*: BU – Activation/deactivation of the acoustic local alarms

- ↳ Press and hold $\text{P} + \text{1}$ for more than 3 seconds
- ↳ Press + to proceed to "LAL"
- ↳ Press P to select "LAL". "LhL" is now shown in the display
- ↳ Press + several times until "BU" is shown in the display
- ↳ Press P to select "BU"
- ↳ Press + or - to activate/deactivate the local acoustic alarms [1 = activated/0 = deactivated]
- ↳ Press P to confirm the set value
 - The local acoustic alarms is configured, proceed to other parameters by pressing P , then navigate by using + or -
- ↳ Leave the user menu by pressing P several times until the cabinet's temperature is shown in the display



- ATTENTION -

High and low temperature alarms set up in the cabinet's controller (including EAL alarms) must be accompanied by additional redundant independent external alarms to ensure maximum item safety.

External alarm settings

External high alarm External low alarm

The following part covers the setting of the upper and lower external temperature alarm limits.

O-10*: EhL – Setting the external upper alarm limit [° C]

- ↳ Press and hold (P) + (1) for more than 3 seconds
- ↳ Press (+) several times until "EAL" is shown in the display
- ↳ Press (P) to select "EAL". "EhL" is now shown in the display
- ↳ Press (P) to select "EhL". The external upper alarm limit is now shown in the display
- ↳ Press (+) or (-) to set the desired value for the external upper alarm limit
- ↳ Press (P) to confirm the set value
 - The external upper alarm limit is now set, proceed to other parameters by pressing (⏪), then navigate by using (+) or (-)
- ↳ Leave the user menu by pressing (⏪) several times until the cabinet's temperature is shown in the display

O-11*: ELL – Setting the external lower alarm limit [° C]

- ↳ Press and hold (P) + (1) for more than 3 seconds
- ↳ Press (+) several times until "EAL" is shown in the display
- ↳ Press (P) to select "EAL". "EhL" is now shown in the display
- ↳ Press (+) to proceed to "ELL"
- ↳ Press (P) to select "ELL". The external lower alarm limit is now shown in the display
- ↳ Press (+) or (-) to set the desired value for the external lower alarm limit
- ↳ Press (P) to confirm the set value
 - The external lower alarm limit is now set, proceed to other parameters by pressing (⏪), then navigate by using (+) or (-)
- ↳ Leave the user menu by pressing (⏪) several times until the cabinet's temperature is shown in the display



- ATTENTION -

High and low temperature alarms set up in the cabinet's controller (including EAL alarms) must be accompanied by additional redundant independent external alarms to ensure maximum item safety.

External high alarm delay

External low alarm delay

The following parts covers the setting of the delay of the external upper and lower alarms.

O-12*: Ehd – Setting the delay of the external upper alarm limit [min.]

- ↳ Press and hold **(P)** + **(1)** for more than 3 seconds
- ↳ Press **(+)** to proceed to "EAL"
- ↳ Press **(P)** to select "EAL". "EhL" is now shown in the display
- ↳ Press **(+)** several times until "Ehd" is shown in the display
- ↳ Press **(P)** to select "Ehd". The external delay of the upper alarm limit is now shown in the display
- ↳ Press **(+)** or **(-)** to set the desired value for the external delay of the upper alarm limit
- ↳ Press **(P)** to confirm the set value
 - The delay of the external upper alarm limit is now set, proceed to other parameters by pressing **(⏏)**, then navigate by using **(+)** or **(-)**
- ↳ Leave the user menu by pressing **(⏏)** several times until the cabinet's temperature is shown in the display

O-13*: ELd – Setting the delay of the external lower alarm limit [min.]

- ↳ Press and hold **(P)** + **(1)** for more than 3 seconds
- ↳ Press **(+)** to proceed to "EAL"
- ↳ Press **(P)** to select "EAL". "EhL" is now shown in the display
- ↳ Press **(+)** several times until "ELd" is shown in the display
- ↳ Press **(P)** to select "ELd". The delay of the external lower alarm limit is now shown in the display
- ↳ Press **(+)** or **(-)** to set the desired value for the delay of the lower alarm limit
- ↳ Press **(P)** to confirm the set value
 - The delay of the external lower alarm limit is now set, proceed to other parameters by pressing **(⏏)**, then navigate by using **(+)** or **(-)**
- ↳ Leave the user menu by pressing **(⏏)** several times until the cabinet's temperature is shown in the display



- ATTENTION -

High and low temperature alarms set up in the cabinet's controller (including EAL alarms) must be accompanied by additional redundant independent external alarms to ensure maximum item safety.

On/Off external door alarm

External door alarm delay

The following parts covers the setting and delay, of the external door alarm.

O-14*: dA – Activation/deactivation of external door alarm

- ↳ Press and hold $\text{P} + \text{1}$ for more than 3 seconds
- ↳ Press + to proceed to "EAL"
- ↳ Press P to select "EAL". "EhL" is now shown in the display
- ↳ Press + several times until "dA" is shown in the display
- ↳ Press P to select "dA"
- ↳ Press + or - to activate/deactivate the external door alarm [1 = activated/0 = deactivated]
- ↳ Press P to confirm the set value
 - The external door alarm is now configured, proceed to other parameters by pressing P , then navigate by using + or -
- ↳ Leave the user menu by pressing P several times until the cabinet's temperature is shown in the display

O-15*: dAd – Setting the delay of the external door alarm [min.]

- ↳ Press and hold $\text{P} + \text{1}$ for more than 3 seconds
- ↳ Press + to proceed to "EAL"
- ↳ Press P to select "EAL". "EhL" is now shown in the display
- ↳ Press + several times until "dAd" is shown in the display
- ↳ Press P to select "dAd". The delay of the external door alarm is now shown in the display
- ↳ Press + or - to set the desired value for the delay of the external door alarm
- ↳ Press P to confirm the set value
 - The delay of the external door alarm is now configured, proceed to other parameters by pressing P , then navigate by using + or -
- ↳ Leave the user menu by pressing P several times until the cabinet's temperature is shown in the display



- ATTENTION -

High and low temperature alarms set up in the cabinet's controller (including EAL alarms) must be accompanied by additional redundant independent external alarms to ensure maximum item safety.

Buzzer – External acoustic settings

The following part covers the setting of the acoustic external alarms.

O-16*: BU – Activation/deactivation of the acoustic external alarms

- ↳ Press and hold $\text{P} + \text{1}$ for more than 3 seconds
- ↳ Press + to proceed to "EAL"
- ↳ Press P to select "EAL". "EhL" is now shown in the display
- ↳ Press + several times until "BU" is shown in the display
- ↳ Press P to select "BU"
- ↳ Press + or - to activate/deactivate the external acoustic alarms [1 = activated/0 = deactivated]
- ↳ Press P to confirm the set value
 - The external acoustic alarms is configured, proceed to other parameters by pressing P , then navigate by using + or -
- ↳ Leave the user menu by pressing P several times until the cabinet's temperature is shown in the display



- ATTENTION -

High and low temperature alarms set up in the cabinet's controller (including EAL alarms) must be accompanied by additional redundant independent external alarms to ensure maximum item safety.

Parameter settings

Sensor offset

The temperature sensors connected to the controller can be offset independently of each other in the parameter settings cAL.

Offset is used in cases where there are deviations in the cabinet's actual operation compared to the display and/or control measurements by independent temperature monitoring.

The cabinet is equipped with an A-sensor and an E-sensor.

The A-sensor is used to manage the cabinet's refrigeration system and is fixated in a given position in the cabinet, not in storage space. The location of the A-sensor must not be altered.

The A-sensor should be offset if the actual temperature in the cabinet does not match the setpoint, despite taking the hysteresis into consideration. Offset of A-sensor is named "cA".

The E-sensor is placed in the cabinet's storage space and can be moved around in the cabinet to get the desired reference point for temperature. The E-sensor is the default display sensor and reference for the alarms. The E-sensor has no effect on control of the refrigeration system.

The E-sensor should be offset if the actual temperature in the cabinet's display, provided that the display sensor for reference is the E-sensor, does not match the independent temperature monitoring used for control. Offset of E-sensor is named "cE".

The F-sensor is placed inside the storage space, close to the airflow of the cold air exiting the air distribution system. The location of the F-sensor must not be altered as this will have an effect on when the low-temperature protection activates.

The F-sensor should be offset if the cut-off temperature for the low-temperature protection, does not match the setpoint temperature for the low-temperature protection. Offset of the F-sensor is named "cF".

Practical example of offset:

Example 1

The temperature in the cabinet is operating colder than the actual setpoint.

With a setpoint of +4 °C, the actual temperature inside the cabinet is between +2 and +4 °C. The desired temperature range is between +3 and +5 °C. This means that "cA", in this case, should be -1.0K, so that the refrigeration system stops 1.0K before and starts 1.0K later than the setpoint normally otherwise would dictate.

Example 2

The temperature in the cabinet is operating warmer than the actual setpoint.

With a setpoint of +4 °C, the actual temperature inside the cabinet is between +4 and +6 °C. The desired temperature range is between +3 and +5 °C. This means that "cA", in this case, should be +1.0K, so that the refrigeration system stops 1.0K later and starts 1.0K earlier than the setpoint normally otherwise would dictate.

Offset of the A-sensor

- ↳ Press and hold (P) + (1) for more than 3 seconds
- ↳ Press (+) several times until "cAL" is shown in the display
- ↳ Press (P) to select "cAL". "cA" is shown in the display
- ↳ Press (P) to select "cA"
- ↳ Press (+) or (-) to offset the A-sensor
- ↳ Press (P) to confirm the set value
 - The A-sensor is now offset, proceed to other parameters by pressing (M), then navigate by using (+) or (-)
- ↳ Leave the user menu by pressing (M) several times the cabinet's temperature is shown in the display

Offset of the E-sensor

- ↳ Press and hold (P) + (1) for more than 3 seconds
- ↳ Press (+) several times until "cAL" is shown in the display
- ↳ Press (P) to select "cAL". "cA" is shown in the display
- ↳ Press (+) until "cE" is shown in the display
- ↳ Press (P) to select "cE"
- ↳ Press (+) or (-) to offset the E-sensor
- ↳ Press (P) to confirm the set value
 - The E-sensor is now offset, proceed to other parameters by pressing (M), then navigate by using (+) or (-)
- ↳ Leave the user menu by pressing (M) several times until the cabinet's temperature is shown in the display

Offset of the F-sensor

- ↳ Press and hold (P) + (1) for more than 3 seconds
- ↳ Press (+) several times until "cAL" is shown in the display
- ↳ Press (P) to select "cAL". "cA" is shown in the display
- ↳ Press (+) until "cF" is shown in the display
- ↳ Press (P) to select "cF"
- ↳ Press (+) or (-) to offset the F-sensor
- ↳ Press (P) to confirm the set value
 - The F-sensor is now offset, proceed to other parameters by pressing (M), then navigate by using (+) or (-)
- ↳ Leave the user menu by pressing (M) several times until the cabinet's temperature is shown in the display

Escorted/set alarm limits

The following part covers the setting of the escorted or set alarm limits.

ALL – Setting of escorted/set alarm limits

- ↳ Press and hold $\text{P} + \text{1}$ for more than 3 seconds
- ↳ Press + several times until "ALL" is shown in the display
- ↳ Press P to select "ALL"
- ↳ Press + or - to select set or escorted alarm limits
- ↳ Press P to confirm the set value
- ↳ Leave the user menu by pressing D several times until the cabinet's temperature is shown in the display

"Set alarm" is fixed, operating independently from the setpoint. The alarm limits will not change and the selected values will remain regardless of the setpoint being altered.

"Escorted alarm" is fixed and locked to the setpoint. The alarm limits will change according to the altered setpoint.

Defrosts/24 hours

The following part covers the setting of the amount of defrosts per 24 hours.

O-17*: dEF – Number of defrosts

- ↳ Press and hold $\text{P} + \text{1}$ for more than 3 seconds
- ↳ Press + several times until “dEF” is shown in the display
- ↳ Press P to select “dEF”
- ↳ Press + or - to set the desired amount of defrosts per 24 hours (factory setting is 4)
- ↳ Press P to confirm the set value
- ↳ Leave the user menu by pressing P several times until the cabinet's temperature is shown in the display

Please note: It is very important that defrosts should not be set to 0 for a prolonged period of time, as this will reduce the cooling capacity of the cabinet.

Display sensor

The following part covers the setting of which the sensor is to be shown in the display

O-18*: dPS – Selection of reference sensor for the display

- ↳ Press and hold $\text{P} + \text{1}$ for more than 3 seconds
- ↳ Press + several times until "dPS" is shown in the display
- ↳ Press P to select "dPS"
- ↳ Press + or - to select either the A- or E-sensor
- ↳ Press P to confirm the set value
- ↳ Leave the user menu by pressing 0 several times until the cabinet's temperature is shown in the display



The dPS only changes the reference sensor for the display, and not the reference sensor for the alarms.



The reference sensor for the refrigeration system is the A-sensor, this cannot be altered.

Electric low-temperature protection

The following part covers the electric low-temperature protection

FP – Activation/deactivation of low-temperature protection

- ↳ Press and hold $\text{P} + \text{1}$ for more than 3 seconds
- ↳ Press + several times until "FP" is shown in the display
- ↳ Press P to select "FP". "Act" is now shown in the display
- ↳ Press P to select "Act"
- ↳ Press - or + to activate/deactivate [1 = activated/0 = deactivated]
- ↳ Press P to confirm the set value
- ↳ Leave the user menu by pressing ⏻ several times until the cabinet's temperature is shown in the display

FP – Setpoint of low-temperature protection

- ↳ Press and hold $\text{P} + \text{1}$ for more than 3 seconds
- ↳ Press + several times until "FP" is shown in the display
- ↳ Press P to select "FP". "Act" is now shown in the display
- ↳ Press + several times until "SEt" is shown in the display
- ↳ Press P to select "SEt"
- ↳ Press - or + to select the setpoint temperature for the low-temperature protection
- ↳ Press P to confirm the set value
- ↳ Leave the user menu by pressing ⏻ several times until the cabinet's temperature is shown in the display

FP – Test of low-temperature protection

- ↳ Press and hold $\text{P} + \text{1}$ for more than 3 seconds
- ↳ Press + several times until "FP" is shown in the display
- ↳ Press P to select "FP". "Act" is now shown in the display
- ↳ Press + to progress to "tES"
- ↳ Press P to select "tES" – Test will then be performed
- ↳ Leave the user menu by pressing ⏻ several times until the cabinet's temperature is shown in the display

FP – Temperature of low-temperature protection sensor

- ↳ Press and hold $\text{P} + \text{1}$ for more than 3 seconds
- ↳ Press + several times until "FP" is shown in the display
- ↳ Press P to select "FP". "Act" is now shown in the display
- ↳ Press + several times until "Pre" is shown in the display
- ↳ Press P to select "Pre"
- ↳ Press P to show the low-temperature protection sensor temperature
- ↳ Leave the user menu by pressing ⏻ several times until the cabinet's temperature is shown in the display

Ordinary use

Load line

The following part shows how items should be placed and stored in the cabinet.

Keep the marked areas in the cabinets clear of all items (see illustrations below), thereby ensuring adequate air circulation, and therein cooling. Do not place items beneath the lowest shelf bracket.

All products to be stored, that are not wrapped or packed, must be covered in order to avoid unnecessary corrosion of the inner parts of the cabinet.



Items placed on the bottom of the cabinet will cause the air circulation to be impeded, which reduces the cabinets' performance. The illustrations below depict examples of maximum load height of a BioPlus and BioMidi cabinet.



The cabinet interior must not be exposed to corrosive atmospheres.

BioPlus

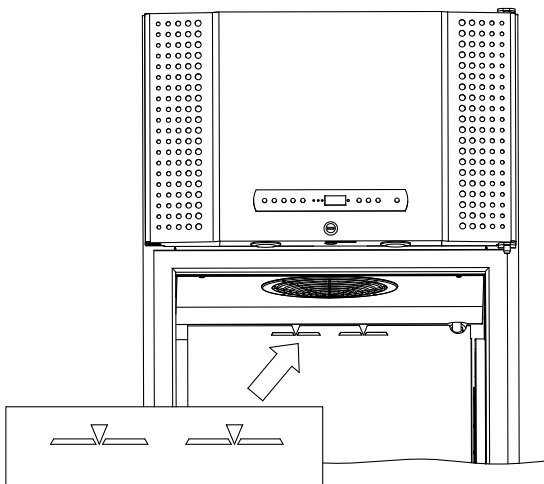

BioMidi

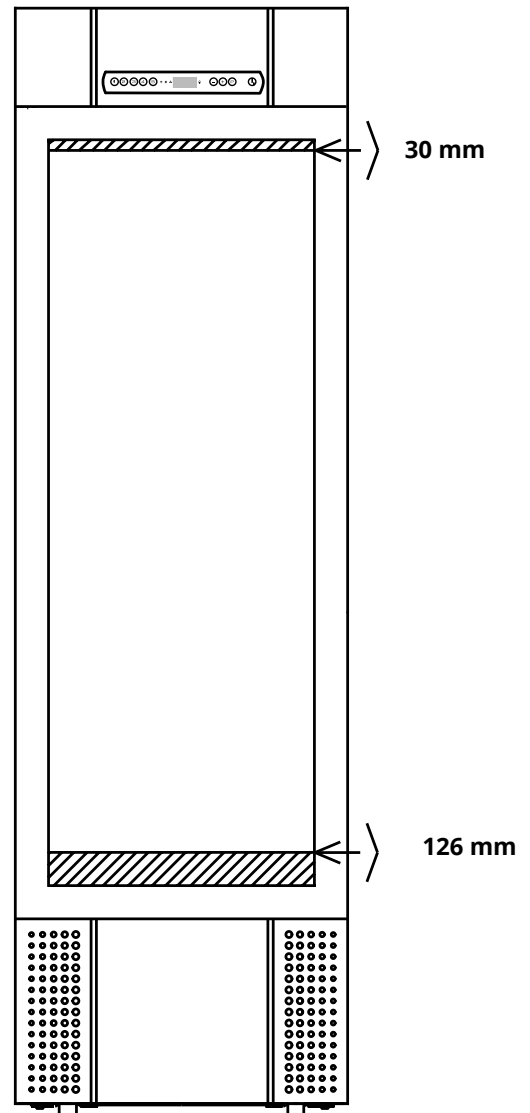

Cleaning

Inadequate cleaning can lead to the cabinet not functioning properly or at all.



The cabinet should be cleaned internally with a mild soap solution (max. 85° C) at suitable intervals and checked thoroughly before it is put into operation again.

Cleaning agents with a pH of 5 ± 1 can be used when a mild soap solution and/or water is used to remove any substance that might damage cabinet components or surfaces. The cleaning agent should be compatible with materials such as steel, alloy, sheet metal, paint, and plastics.

The compressor compartment and in particular the condenser must be kept free from dust and dirt. This is best done with a vacuum cleaner and a brush. The air filters on the condenser and the front panel should be removed and cleaned with warm water (max. 50° C).

It is recommended that the re-evaporation tray is checked regularly for foreign objects and cleaned at least once a year.

Do not flush the compressor compartment and evaporator with water as this may cause short-circuits in the electrical system.

Cleaning agents containing chlorine or compounds of chlorine as well as other corrosive agents, may not be used, as they might cause corrosion to the stainless panels of the cabinet and the evaporator system.

The location of the condenser for both bottom and top-mounted compressors are illustrated below

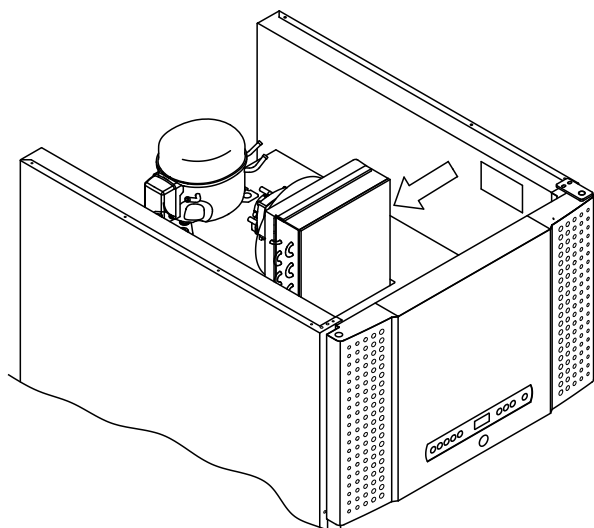

BioPlus

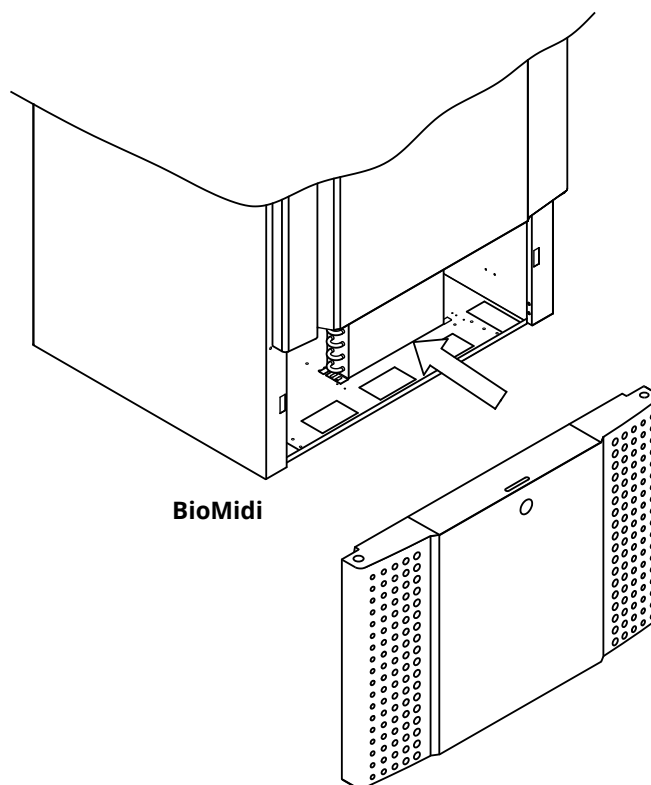

BioMidi

Door gasket

The following part covers the importance of a properly functioning door gasket.

The door gaskets are an important part of a cabinet. Impaired door gaskets can lead to increased humidity, iced up evaporator (thus reduced cooling capacity), and in some cases, decreased longevity of the cabinet.

It is therefore very important to be aware of the door gasket's condition. Regular inspection is recommended.

The door gasket should be cleaned regularly with a mild soap solution.

If a gasket is to be replaced, please contact your local Gram BioLine distributor.

The illustration below shows the location of the door gasket

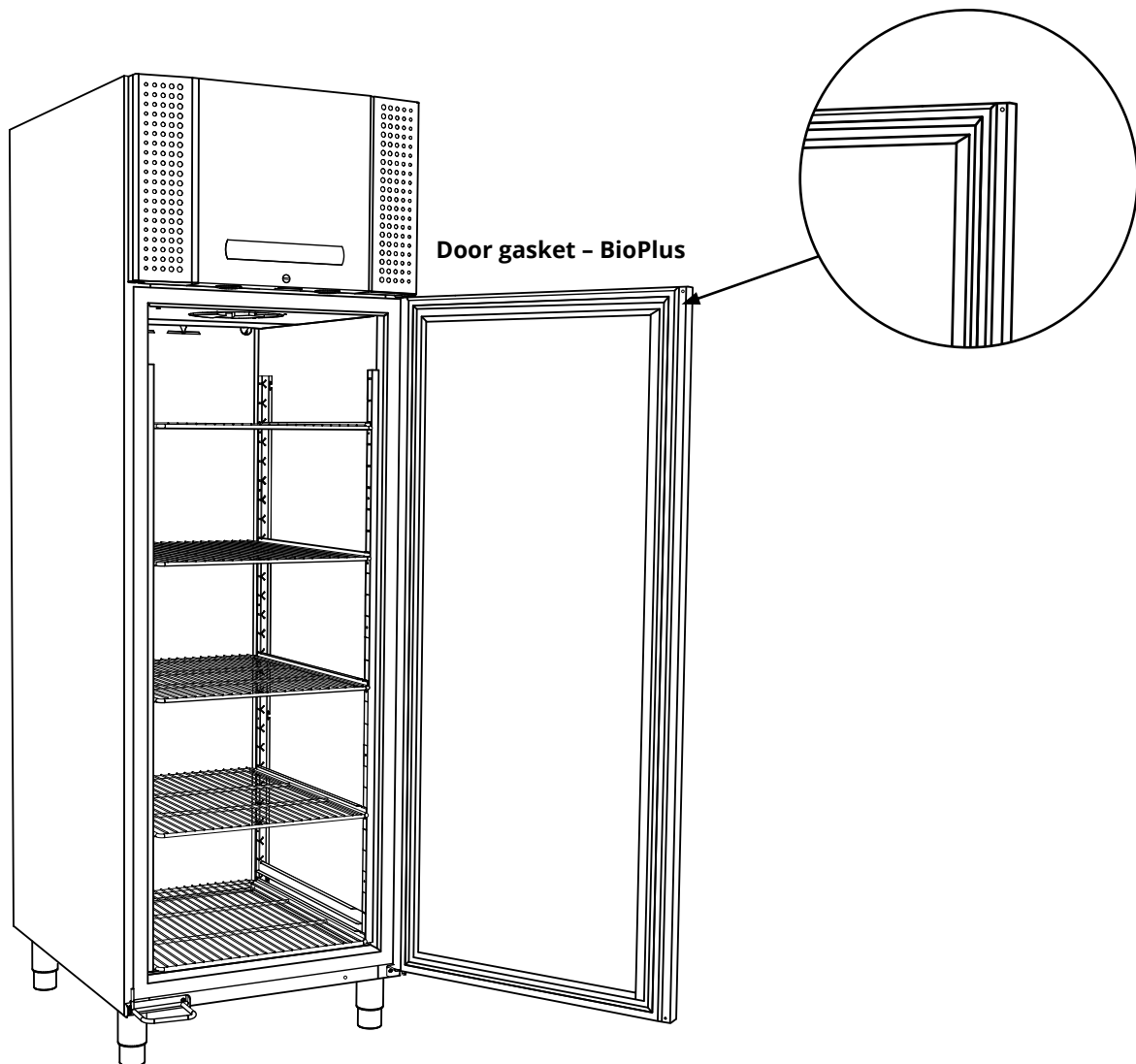

Responsibility

Read the following carefully, for information on technical safety and responsibility on Gram BioLine products.

 **- WARNING -**
DO NOT OPEN, MAINTAIN OR SERVICE IN AN AREA WHEN AN EXPLOSIVE ATMOSPHERE IS PRESENT.



During servicing make sure the appliance is switched off at the socket before service is performed on the cabinet. It is not sufficient to switch the cabinet to standby on the On/Standby  key, as current will persist in some electrical parts of the cabinet.



Warranty may be void in the event of the cabinet being used for applications other than its intended use, or otherwise not in accordance with the guidelines stipulated in the instructions for use.



Defective parts must be replaced with original parts from Gram BioLine. Gram BioLine can only guarantee functional and safety requirements on the cabinets, if above mentioned is adhered to.



The cabinet should be checked at least once yearly by a Gram BioLine-authorized technician. The refrigeration system and the hermetically sealed compressor require no maintenance. However the condenser requires regular cleaning.



Be aware that cabinets using hydrocarbons (HC) as refrigerant, may require special handling by qualified technicians.

Type/number plate

If refrigeration fails, first look to see whether the cabinet has been unintentionally switched off, or whether a fuse has blown.

If the cause of failure cannot be found, contact your supplier quoting type and S/N. This information can be found on the type/number plate.

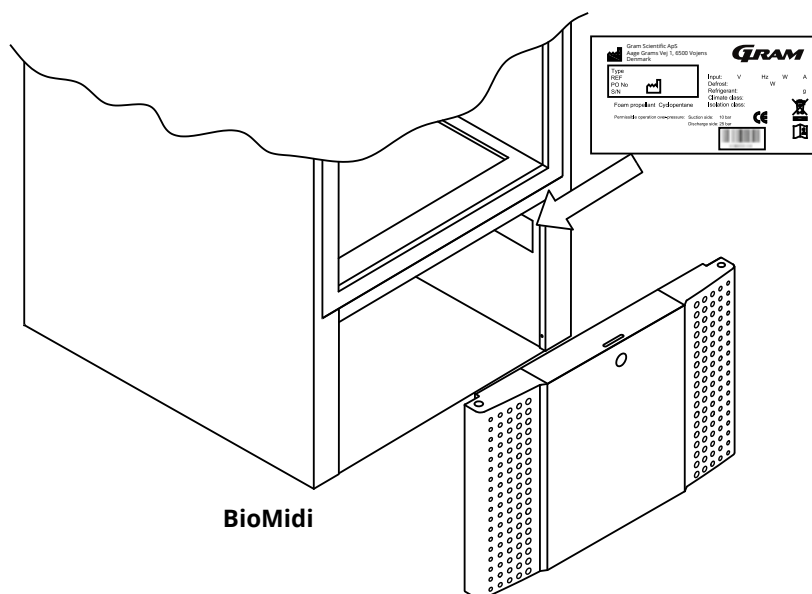
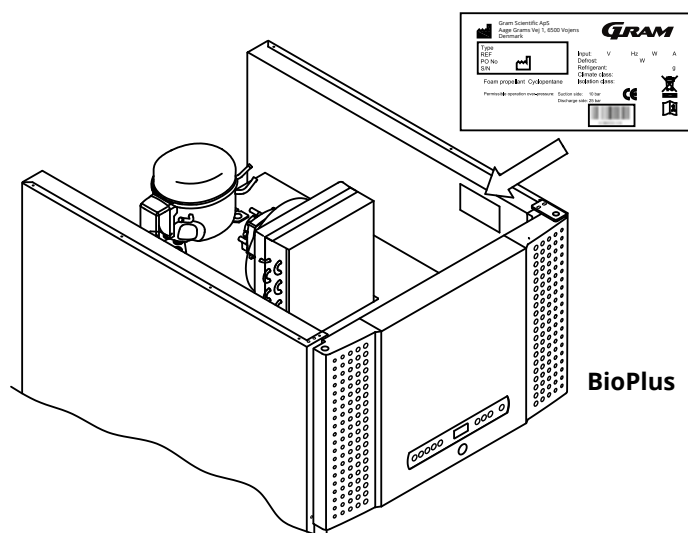

Defrost water

The cabinet creates defrost water, that is directed out into a re-evaporation tray at the back of the cabinet.

Defrost water is led through a tube in the insulation to the re-evaporation tray at the back of the cabinet.



It is recommended that the re-evaporation tray is checked regularly for foreign objects and cleaned accordingly. This shall only be done while the cabinet is turned off.

Be careful not to damage the defrost water tube and the heating element (located in the tray) when cleaning.

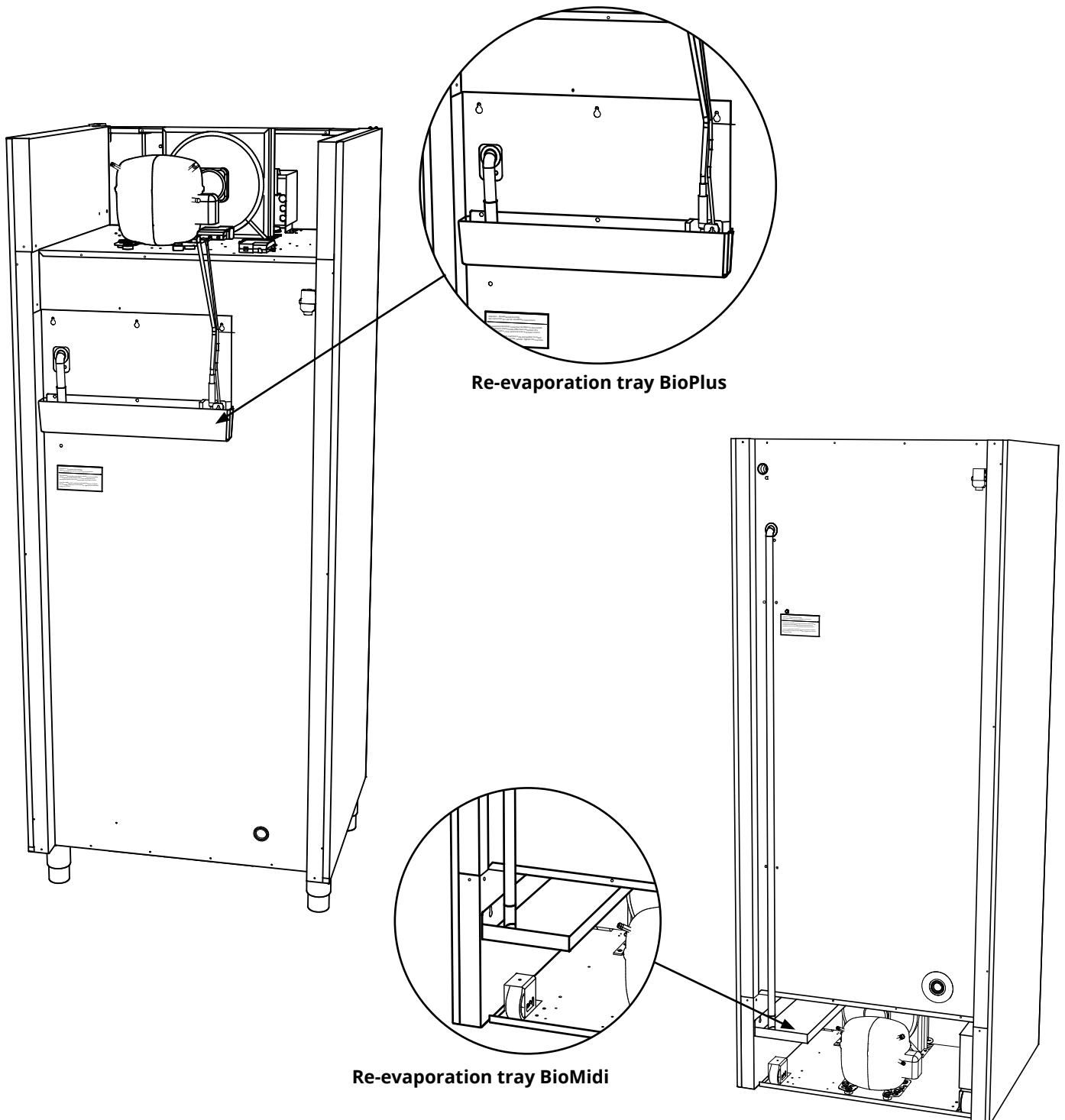

Door self-closing mechanism

Please note: BioMidi and BioPlus cabinets are equipped with doors that have a door self-closing mechanism.

The door is equipped with a door self-closing mechanism. Open the door up to 90°, and it will shut by itself. Open the door more than 90° and door will remain open.

Door lock

The BioMidi and BioPlus cabinets are equipped with a safety lock.

The illustrations below shows the safety lock.

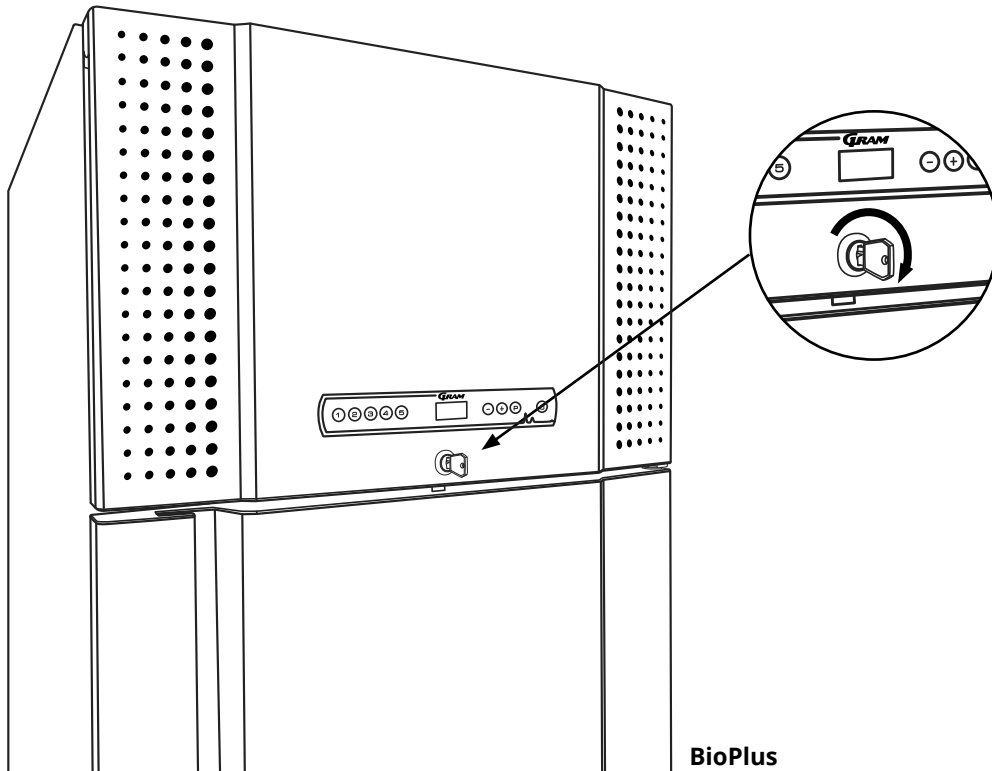
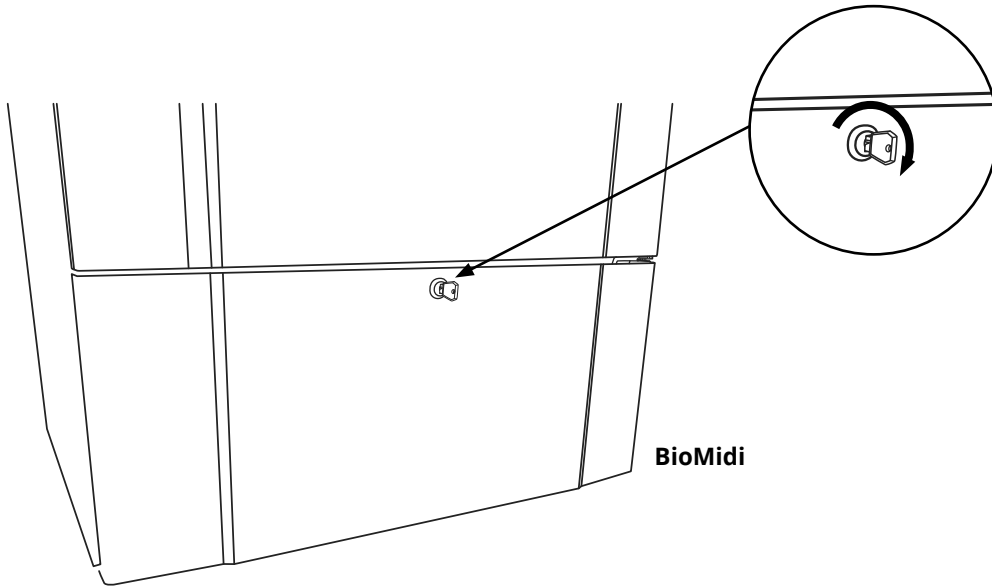

Access port

All BioLine cabinets are equipped with an access port on the back of the cabinets, this can be used to easily fit external sensors and the like.

The illustration below shows the access port in the BioPlus cabinet. All access ports are constructed in the same fashion, with a conical polystyrene plug (fitted from the back of the cabinet) and a plastic cap (fitted from the inside of the cabinet).



It is very important to refit the polystyrene plug (position 1) and plastic cap (position 2) after mounting a sensor, probe etc. failing to do so can result in lowered performance or malfunction of the cabinet.

Due to the intended use of the BioMidi and BioPlus cabinets, it is critical to ensure a proper seal in the access port.

Access ports are clearly marked "Access port" on the cabinet.

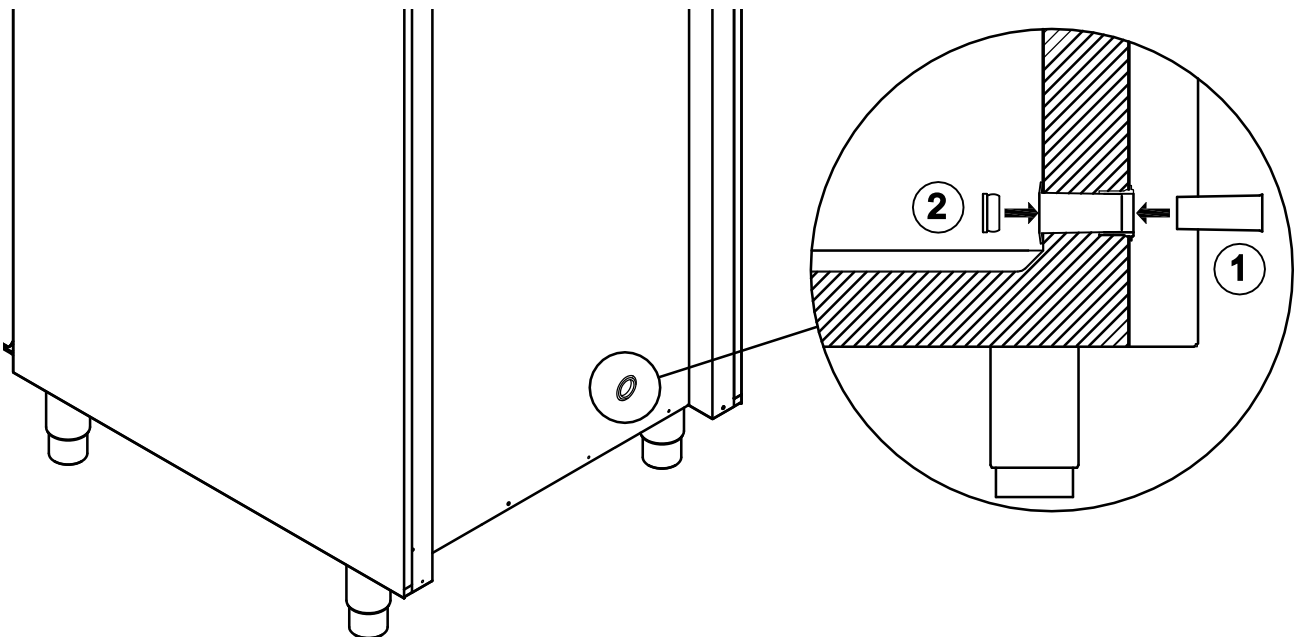

Important

In the event of need for product support. Do not hesitate to contact us at: support@gram-bioline.com.



– IMPORTANT –

1. There may be sharp edges on the cabinet housing, compressor room, and interior. Show due diligence when handling the cabinet, negligence of these precautions can lead to injuries.
2. Be cautious about the potential risk of body parts getting wedged in the frame slot between the door and the cabinet when opening or closing the cabinet. Exercise due diligence to avoid any accidents. Failure to take these precautions may result in injuries.
3. Exercise caution to prevent the potential wedging of body parts in the drawer column between the drawers and the interior of the cabinet. Demonstrate due diligence to avoid accidents, as negligence in observing these precautions may lead to injuries.
4. Be particularly vigilant in relation to closing doors with self-close mechanism as these are spring-loaded. Negligence of these precautions can lead to injuries.
5. Unlocked castors can lead to unexpected movements of the cabinet. Lock the castors after installation. Negligence of these precautions can lead to injuries.
6. The re-evaporation tray, re-evaporation tray heating element, pressure pipes and compressor develops considerable heat during operation. Assure yourself that these components are sufficiently tempered before touching. Negligence of these precautions can lead to injuries.
7. The evaporator develops considerable cold during operation. Reassure yourself that the evaporator is sufficiently tempered before touching. Negligence of this precaution may lead to injuries.
8. The fan may cause injury during operation, avoiding touching the fans while the cabinet is connected to the mains. Negligence of these precautions can lead to injuries.
9. No unauthorised modification are allowed.

Disposal

This part describes the disposal of electrical and electronic equipment.

At Gram BioLine we are dedicated to environmental sustainability and comply fully with the Waste Electrical and Electronic Equipment (WEEE) Directive.

Electrical and electronic equipment (EEE) contains materials, components and substances that can be dangerous and harmful to human health and the environment if the waste (WEEE) is not disposed of correctly. When disposing the appliance in an EU Member State, it should be in accordance with the Waste Electrical and Electronic Equipment Regulations (WEEE).

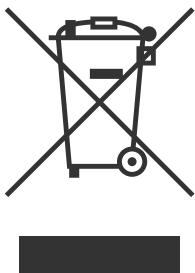

Products that are labelled with a “crossed-out wheeled bin” are electric and electronic equipment. The crossed-out wheeled bin symbolizes that waste of this type cannot be disposed of with unsorted municipal waste but must be collected separately.

This refrigerator or freezer is specifically designed for bioscience purposes, it is therefore important to thoroughly clean the appliance to ensure that no residues or harmful substances remain. While it is not a requirement under the (WEEE) Directive to document the cleaning, it is considered good practice to ensure the refrigerator is free of contamination before it is sent for recycling or disposal. This helps protect individuals responsible for handling the appliance and ensures a safe and environmentally friendly recycling process.

Correct disposal and recycling of electrical and electronic equipment help reduce waste and minimize environmental impact. By adhering to proper handling practices, your organization supports pollution prevention and resource conservation. Recycled materials are sorted, cleaned, and processed for reuse, contributing to sustainability and reducing the need for new raw materials.



Should you have any uncertainties, please feel free to contact Gram BioLine for professional support and guidance.

BioMidi 425

General data – BioMidi 425

Technical specifications	Data
Connection	230 VAC/50 Hz
Control Unit	Gram Control Unit with voltage-free contact, alarms, and offset function
Alarms	Acoustic and visual, High/Low temperature alarms and door alarm
Alarm ports	Voltage-free contact
Access port	1 pc. ø24.5 mm
Gross volume	425 litres
Net volume	303 litres
Door	Left or right hinged
Material interior	Aluminium/stainless steel, or stainless steel
Materiale exterior	White lacquered steel, or stainless steel
Insulation	60 mm polyurethane with HFC-free cyclopentane propellant
Dimensions – W x D x H	600 x 731 x 1980/2000 mm (RR & RF) 622 x 731 x 1980/2000 mm (EF)
Air system	BioLine ventilated air distribution system
Defrost system	Automatic smart defrost with re-evaporation of the defrost water
IP class	IP21

BioMidi RR425 H - with solid door

Technical specifications	Data
Temperature range	+2/+20 °C
Ambient temperature range	+10/+43 °C
Software variant	K2+
K-Value	0.31 W/(m ² *K)
ATEX Marking	II 3G Ex nA nC nL IIB T5 Gc
ATEX certificate	-
Refrigerant	R134a
Refrigerant charge	205 g
Refrigeration capacity at -10 °C	279 Watt
GWP - CO ₂ e	293.15
Energy consumption	1.19 kWh/24h
Heat emission 100 %	217 Watt
Heat emission default setpoint	50 Watt
Nominal consumption	222 Watt
Start current	10.5A
Sound level	-

BioMidi RR425 H - with glass door

Technical specifications	Data
Temperature range	+2/+20 °C
Ambient temperature range	+10/+38 °C
Software variant	K2+
K-Value	0.529 W/(m ² *K)
ATEX Marking	II 3G Ex nA nC nL IIB T5 Gc
ATEX certificate	-
Refrigerant	R134a
Refrigerant charge	205 g
Refrigeration capacity at -10 °C	279 Watt
GWP - CO ₂ e	293.15
Energy consumption	1.87 kWh/24h
Heat emission 100 %	218 Watt
Heat emission default setpoint	78 Watt
Nominal consumption	222 Watt
Start current	10.5A
Sound level	-



BioMidi RF425 H – with solid door

Technical specifications	Data
Temperature range	-25/-5 °C
Ambient temperature range	+10/+43 °C
Software variant	F51
K-Value	0.31 W/(m ² *K)
ATEX Marking	II 3G Ex nA nC nL IIB T3 Gc
ATEX certificate	-
Refrigerant	R404A
Refrigerant charge	200 g
Refrigeration capacity at -25 °C	424 Watt
GWP – CO ₂ e	784.4
Energy consumption	4.45 kWh/24h
Heat emission 100 %	424 Watt
Heat emission default setpoint	185 Watt
Nominal consumption	426 Watt
Start current	12.6A
Sound level	44.7 dB(A)

BioMidi EF425 H – extended freezer – with solid door

Technical specifications	Data
Temperature range	-40/-5 °C
Ambient temperature range	+10/+30 °C
Software variant	E5+
K-Value	0.31 W/(m ² *K)
ATEX Marking	II 3G Ex nA nC nL IIB T3 Gc
ATEX certificate	-
Refrigerant	R404A
Refrigerant charge	270 g
Refrigeration capacity at -40 °C	378 Watt
GWP – CO ₂ e	1058.94
Energy consumption	9.40 kWh/24h
Heat emission 100 %	549 Watt
Heat emission default setpoint	392 Watt
Nominal consumption	595 Watt
Start current	23.4A
Sound level	-

BioMidi RR425 G - with solid door

Technical specifications	Data
Temperature range	+2/+20 °C
Ambient temperature range	+10/+43 °C
Software variant	K2+
K-Value	0.529 W/(m ² *K)
ATEX Marking	II 3G Ex nA nC nL IIB T5 Gc
ATEX certificate	-
Refrigerant	R290
Refrigerant charge	102 g
Refrigeration capacity at -10 °C	389 Watt
GWP - CO ₂ e	0.3366
Energy consumption	1.27 kWh/24h
Heat emission 100 %	260 Watt
Heat emission default setpoint	53 Watt
Nominal consumption	258 Watt
Start current	9.7A
Sound level	47.2 dB(A)

BioMidi RR425 G - with glass door

Technical specifications	Data
Temperature range	+2/+20 °C
Ambient temperature range	+10/+38 °C
Software variant	K2+
K-Value	0.47 W/(m ² *K)
ATEX Marking	II 3G Ex nA nC nL IIB T5 Gc
ATEX certificate	-
Refrigerant	R290
Refrigerant charge	102 g
Refrigeration capacity at -10 °C	389 Watt
GWP - CO ₂ e	0.3366
Energy consumption	1.63 kWh/24h
Heat emission 100 %	249 Watt
Heat emission default setpoint	68 Watt
Nominal consumption	258 Watt
Start current	9.7A
Sound level	47.2 dB(A)



BioMidi RF425 G – with solid door

Technical specifications	Data
Temperature range	-25/-5 °C
Ambient temperature range	+10/+43 °C
Software variant	F51
K-Value	0.31 W/(m ² *K)
ATEX Marking	II 3G Ex nA nC nL IIB T3 Gc
ATEX certificate	–
Refrigerant	R290
Refrigerant charge	86 g
Refrigeration capacity at -25 °C	374 Watt
GWP – CO ₂ e	0.2838
Energy consumption	3.61 kWh/24h
Heat emission 100 %	341 Watt
Heat emission default setpoint	150 Watt
Nominal consumption	336 Watt
Start current	13.6A
Sound level	46.3 dB(A)

BioMidi EF425 G – extended freezer – with solid door

Technical specifications	Data
Temperature range	-40/-5 °C
Ambient temperature range	+10/+30 °C
Software variant	E5+
K-Value	0.31 W/(m ² *K)
ATEX Marking	II 3G Ex nA nC nL IIB T3 Gc
ATEX certificate	–
Refrigerant	R290
Refrigerant charge	105 g
Refrigeration capacity at -40 °C	338 Watt
GWP – CO ₂ e	0.3465
Energy consumption	8.93 kWh/24h
Heat emission 100 %	529 Watt
Heat emission default setpoint	372 Watt
Nominal consumption	565 Watt
Start current	23.5A
Sound level	–

BioMidi 625

General data – BioMidi 625

Technical specifications	Data
Connection	230 VAC, 50 Hz
Control Unit	Gram Control Unit with voltage-free contact, alarms and offset function
Alarms	Acoustic and visual, High/Low temperature alarms and door alarm
Alarm ports	Voltage-free contact
Access port	1 pc. ø24.5 mm
Gross volume	625 litres
Net volume	451 litres
Door	Left or right hinged
Material interior	Aluminium/stainless steel or stainless steel
Materiale exterior	White lacquered steel or stainless steel
Insulation	60 mm polyurethane with HFC-free cyclopentane propellant
Dimensions – W x D x H	815 x 731 x 1980/2000 mm
Air system	BioLine ventilated air distribution system
Defrost system	Automatic smart defrost with re-evaporation of the defrost water
IP class	IP21



BioMidi RR625 H - with solid door

Technical specifications	Data
Temperature range	+2/+20 °C
Ambient temperature range	+10/+43 °C
Software variant	K2+
K-Value	0.31 W/(m ² *K)
ATEX Marking	II 3G Ex nA nC nL IIB T5 Gc
ATEX certificate	-
Refrigerant	R134a
Refrigerant charge	230 g
Refrigeration capacity at -10 °C	314 Watt
GWP - CO ₂ e	328.9
Energy consumption	1.33 kWh/24h
Heat emission 100 %	247 Watt
Heat emission default setpoint	55 Watt
Nominal consumption	244 Watt
Start current	11.4A
Sound level	-

BioMidi RR625 H - with glass door

Technical specifications	Data
Temperature range	+2/+20 °C
Ambient temperature range	+10/+38 °C
Software variant	K2+
K-Value	0.5574 W/(m ² *K)
ATEX Marking	II 3G Ex nA nC nL IIB T5 Gc
ATEX certificate	-
Refrigerant	R134a
Refrigerant charge	230 g
Refrigeration capacity at -10 °C	314 Watt
GWP - CO ₂ e	328.9
Energy consumption	1.82 kWh/24h
Heat emission 100 %	245 Watt
Heat emission default setpoint	76 Watt
Nominal consumption	244 Watt
Start current	11.4A
Sound level	-



BioMidi RF625 H – with solid door

Technical specifications	Data
Temperature range	-25/-5 °C
Ambient temperature range	+10/+43 °C
Software variant	F51
K-Value	0.31 W/(m ² *K)
ATEX Marking	II 3G Ex nA nC nL IIB T2 Gc
ATEX certificate	–
Refrigerant	R404A
Refrigerant charge	240 g
Refrigeration capacity at -25 °C	616 Watt
GWP – CO ₂ e	941.28
Energy consumption	4.74 kWh/24h
Heat emission 100 %	553 Watt
Heat emission default setpoint	198 Watt
Nominal consumption	558 Watt
Start current	19.6A
Sound level	47.4 dB(A)



BioMidi RR625 G - with solid door

Technical specifications	Data
Temperature range	+2/+20 °C
Ambient temperature range	+10/+43 °C
Software variant	K2+
K-Value	0.31 W/(m ² *K)
ATEX Marking	II 3G Ex nA nC nL IIB T5 Gc
ATEX certificate	-
Refrigerant	R290
Refrigerant charge	102 g
Refrigeration capacity at -10 °C	389 Watt
GWP - CO ₂ e	0.3366
Energy consumption	1.30 kWh/24h
Heat emission 100 %	255 Watt
Heat emission default setpoint	54 Watt
Nominal consumption	258 Watt
Start current	9.7A
Sound level	46.6 dB(A)

BioMidi RR625 G - with glass door

Technical specifications	Data
Temperature range	+2/+20 °C
Ambient temperature range	+10/+38 °C
Software variant	K2+
K-Value	0.5574 W/(m ² *K)
ATEX Marking	II 3G Ex nA nC nL IIB T5 Gc
ATEX certificate	-
Refrigerant	R290
Refrigerant charge	102 g
Refrigeration capacity at -10 °C	389 Watt
GWP - CO ₂ e	0.3366
Energy consumption	1.64 kWh/24h
Heat emission 100 %	253 Watt
Heat emission default setpoint	68 Watt
Nominal consumption	258 Watt
Start current	9.7A
Sound level	46.6 dB(A)

BioMidi RF625 G
- with solid door

Technical specifications	Data
Temperature range	-25/-5 °C
Ambient temperature range	+10/+43 °C
Software variant	F51
K-Value	0.31 W/(m ² *K)
ATEX Marking	II 3G Ex nA nC nL IIB T2 Gc
ATEX certificate	-
Refrigerant	R290
Refrigerant charge	95 g
Refrigeration capacity at -25 °C	512 Watt
GWP - CO ₂ e	0.3135
Energy consumption	4.03 kWh/24h
Heat emission 100 %	445 Watt
Heat emission default setpoint	168 Watt
Nominal consumption	460 Watt
Start current	13.1A
Sound level	48.4 dB(A)

BioPlus 500

General data – BioPlus 500

Technical specifications	Data
Connection	230 VAC/50 Hz
Control Unit	Gram Control Unit with voltage-free contact, E-sensor, dry cooling and offset function
Alarms	Acoustic and visual, High/Low temperature alarms and door alarm
Alarm ports	Voltage-free contact
Access port	1 pc. ø24.5 mm
Gross volume	500 litres
Net volume	365 litres
Door	Left or right hinged
Material interior	Stainless steel
Material exterior	White lacquered steel or stainless steel
Insulation	60 mm polyurethane with HFC-free cyclopentane propellant
Dimensions – W x D x H	600 x 805 x 2025/2275 mm
Air system	BioLine ventilated air distribution system
Defrost system	Automatic smart defrost with re-evaporation of the defrost water
IP class	IP21

BioPlus ER500 H – with solid door

Technical specifications	Data
Temperature range	-2/+20 °C
Ambient temperature range	+10/+43 °C
Software variant	M5+
K-Value	0.31 W/(m ² *K)
ATEX Marking	II 3G Ex nA nC nL IIB T2 Gc
ATEX certificate	-
Refrigerant	R134a
Refrigerant charge	260 g
Refrigeration capacity at -10 °C	314 Watt
GWP – CO ₂ e	371.8
Energy consumption	1.37 kWh/24h
Heat emission 100 %	318 Watt
Heat emission default setpoint	57 Watt
Nominal consumption	304 Watt
Start current	11.4A
Sound level	-

BioPlus ER500 H – with glass door

Technical specifications	Data
Temperature range	-2/+20 °C
Ambient temperature range	+10/+38 °C
Software variant	M5+
K-Value	0.5199 W/(m ² *K)
ATEX Marking	II 3G Ex nA nC nL IIB T2 Gc
ATEX certificate	-
Refrigerant	R134a
Refrigerant charge	260 g
Refrigeration capacity at -10 °C	314 Watt
GWP – CO ₂ e	371.8
Energy consumption	1.88 kWh/24h
Heat emission 100 %	324.08 Watt
Heat emission default setpoint	79 Watt
Nominal consumption	304 Watt
Start current	11.4A
Sound level	-



BioPlus RF500 H - with solid door

Technical specifications	Data
Temperature range	-25/-5 °C
Ambient temperature range	+10/+43 °C
Software variant	F51
K-Value	0.31 W/(m ² *K)
ATEX Marking	II 3G Ex nA nC nL IIB T2 Gc
ATEX certificate	-
Refrigerant	R404A
Refrigerant charge	250 g
Refrigeration capacity at -25 °C	616 Watt
GWP - CO ₂ e	980.5
Energy consumption	4.78 kWh/24h
Heat emission 100 %	519 Watt
Heat emission default setpoint	199 Watt
Nominal consumption	558 Watt
Start current	19.6A
Sound level	-

BioPlus ER500 G - with solid door

Technical specifications	Data
Temperature range	-2/+20 °C
Ambient temperature range	+10/+43 °C
Software variant	M5+
K-Value	0.31 W/(m ² *K)
ATEX Marking	II 3G Ex nA nC nL IIB T2 Gc
ATEX certificate	-
Refrigerant	R290
Refrigerant charge	95 g
Refrigeration capacity at -10 °C	389 Watt
GWP - CO ₂ e	0.3135
Energy consumption	1.26 kWh/24h
Heat emission 100 %	320 Watt
Heat emission default setpoint	53 Watt
Nominal consumption	318 Watt
Start current	9.7A
Sound level	46.2 dB(A)

BioPlus ER500 G - with glass door

Technical specifications	Data
Temperature range	-2/+20 °C
Ambient temperature range	+10/+38 °C
Software variant	M5+
K-Value	0.5199 W/(m ² *K)
ATEX Marking	II 3G Ex nA nC nL IIB T2 Gc
ATEX certificate	-
Refrigerant	R290
Refrigerant charge	95 g
Refrigeration capacity at -10 °C	389 W
GWP - CO ₂ e	0.3135
Energy consumption	1.67 kWh/24h
Heat emission 100 %	316 Watt
Heat emission default setpoint	70 Watt
Nominal consumption	318 Watt
Start current	9.7A
Sound level	46.2 dB(A)



BioPlus RF500 G - with solid door

Technical specifications	Data
Temperature range	-25/-5 °C
Ambient temperature range	+10/+43 °C
Software variant	F51
K-Value	0.31 W/(m ² *K)
ATEX Marking	II 3G Ex nA nC nL IIB T2 Gc
ATEX certificate	-
Refrigerant	R290
Refrigerant charge	92 g
Refrigeration capacity at -25 °C	374 Watt
GWP - CO ₂ e	0.3036
Energy consumption	3.83 kWh/24h
Heat emission 100 %	351 Watt
Heat emission default setpoint	160 Watt
Nominal consumption	336 Watt
Start current	10.4A
Sound level	48.7 dB(A)

BioPlus 600D

General data – BioPlus 600D

Technical specifications	Data
Connection	230 VAC/50 Hz
Control Unit	Gram Control Unit with voltage-free contact, E-sensor, dry cooling and offset function
Alarms	Acoustic and visual, High/Low temperature alarms and door alarm
Alarm ports	Voltage-free contact
Access port	1 pc. ø24.5 mm
Gross volume	600 litres
Net volume	432 litres
Door	Left or right hinged
Material interior	Stainless steel
Materiale exterior	White lacquered steel or stainless steel
Insulation	60 mm polyurethane with HFC-free cyclopentane propellant
Dimensions – W x D x H	695 x 876 x 1875/2125 mm
Air system	BioLine ventilated air distribution system
Defrost system	Automatic smart defrost with re-evaporation of defrost water
IP class	IP21



BioPlus ER600D H - with solid door

Technical specifications	Data
Temperature range	-2/+20 °C
Ambient temperature range	+10/+43 °C
Software variant	M5+
K-Value	0.31 W/(m ² *K)
ATEX Marking	II 3G Ex nA nC nL IIB T2 Gc
ATEX certificate	-
Refrigerant	R134a
Refrigerant charge	230 g
Refrigeration capacity at -10 °C	314 Watt
GWP - CO ₂ e	328.9
Energy consumption	1.30 kWh/24h
Heat emission 100 %	312 Watt
Heat emission default setpoint	54 Watt
Nominal consumption	306 Watt
Start current	11.4A
Sound level	-

BioPlus ER600D H - with glass door

Technical specifications	Data
Temperature range	-2/+20 °C
Ambient temperature range	+10/+38 °C
Software variant	M5+
K-Value	0.5189 W/(m ² *K)
ATEX Marking	II 3G Ex nA nC nL IIB T2 Gc
ATEX certificate	-
Refrigerant	R134a
Refrigerant charge	230 g
Refrigeration capacity at -10 °C	314 Watt
GWP - CO ₂ e	328.9
Energy consumption	1.64 kWh/24h
Heat emission 100 %	309 Watt
Heat emission default setpoint	68 Watt
Nominal consumption	306 Watt
Start current	11.4A
Sound level	-



BioPlus RF600D H – with solid door

Technical specifications	Data
Temperature range	-25/-5 °C
Ambient temperature range	+10/+43 °C
Software variant	F51
K-Value	0.31 W/(m ² *K)
ATEX Marking	II 3G Ex nA nC nL IIB T2 Gc
ATEX certificate	-
Refrigerant	R404A
Refrigerant charge	230 g
Refrigeration capacity at -25 °C	616 Watt
GWP – CO ₂ e	902.06
Energy consumption	4.60 kWh/24h
Heat emission 100 %	506 Watt
Heat emission default setpoint	192 Watt
Nominal consumption	580 Watt
Start current	19.6A
Sound level	-



BioPlus ER600D G - with solid door

Technical specifications	Data
Temperature range	-2/+20 °C
Ambient temperature range	+10/+43 °C
Software variant	M5+
K-Value	0.31 W/(m ² *K)
ATEX Marking	II 3G Ex nA nC nL IIB T2 Gc
ATEX certificate	-
Refrigerant	R290
Refrigerant charge	102 g
Refrigeration capacity at -10 °C	389 Watt
GWP - CO ₂ e	0.3366
Energy consumption	1.26 kWh/24h
Heat emission 100 %	316 Watt
Heat emission default setpoint	52 Watt
Nominal consumption	320 Watt
Start current	9.7A
Sound level	46 dB(A)

BioPlus ER600D G - with glass door

Technical specifications	Data
Temperature range	-2/+20 °C
Ambient temperature range	+10/+38 °C
Software variant	M5+
K-Value	0.5189 W/(m ² *K)
ATEX Marking	II 3G Ex nA nC nL IIB T2 Gc
ATEX certificate	-
Refrigerant	R290
Refrigerant charge	102 g
Refrigeration capacity at -10 °C	389 Watt
GWP - CO ₂ e	0.3366
Energy consumption	1.71 kWh/24h
Heat emission 100 %	321 Watt
Heat emission default setpoint	71 Watt
Nominal consumption	320 Watt
Start current	9.7A
Sound level	46 dB(A)

BioPlus RF600D G
- with solid door

Technical specifications	Data
Temperature range	-25/-5 °C
Ambient temperature range	+10/+43 °C
Software variant	F51
K-Value	0.31 W/(m ² *K)
ATEX Marking	II 3G Ex nA nC nL IIB T2 Gc
ATEX certificate	-
Refrigerant	R290
Refrigerant charge	92 g
Refrigeration capacity at -25 °C	512 Watt
GWP - CO ₂ e	0.3036
Energy consumption	4.03 kWh/24h
Heat emission 100 %	444 Watt
Heat emission default setpoint	168 Watt
Nominal consumption	482 Watt
Start current	13.1A
Sound level	47.3 dB(A)

BioPlus 600W

General data – BioPlus 600W

Technical specifications	Data
Connection	230 VAC/50 Hz
Control Unit	Gram Control Unit with voltage-free contact, E-sensor, dry cooling and offset function
Alarms	Acoustic and visual, High/Low temperature alarms and door alarm
Alarm ports	Voltage-free contact
Access port	1 pc. ø24.5 mm
Gross volume	600 litres
Net volume	432 litres
Door	Left or right hinged
Material interior	Stainless steel
Materiale exterior	White lacquered steel or stainless steel
Insulation	60 mm polyurethane with HFC-free cyclopentane propellant
Dimensions – W x D x H	815 x 756 x 1875/2125 mm
Air system	BioLine ventilated air distribution system
Defrost system	Automatic smart defrost with re-evaporation of defrost water
IP class	IP21

BioPlus ER600W H - with solid door

Technical specifications	Data
Temperature range	-2/+20 °C
Ambient temperature range	+10/+43 °C
Software variant	M5+
K-Value	0.31 W/(m ² *K)
ATEX Marking	II 3G Ex nA nC nL IIB T2 Gc
ATEX certificate	-
Refrigerant	R134a
Refrigerant charge	230 g
Refrigeration capacity at -10 °C	314 Watt
GWP - CO ₂ e	328.9
Energy consumption	1.52 kWh/24h
Heat emission 100 %	315 Watt
Heat emission default setpoint	64 Watt
Nominal consumption	306 Watt
Start current	11.4A
Sound level	-

BioPlus ER600W H - with glass door

Technical specifications	Data
Temperature range	-2/+20 °C
Ambient temperature range	+10/+38 °C
Software variant	M5+
K-Value	0.5563 W/(m ² *K)
ATEX Marking	II 3G Ex nA nC nL IIB T2 Gc
ATEX certificate	-
Refrigerant	R134a
Refrigerant charge	230 g
Refrigeration capacity at -10 °C	314 Watt
GWP - CO ₂ e	328.9
Energy consumption	1.89 kWh/24h
Heat emission 100 %	250 Watt
Heat emission default setpoint	79 Watt
Nominal consumption	306 Watt
Start current	11.4A
Sound level	-



BioPlus RF600W H – with solid door

Technical specifications	Data
Temperature range	-25/-5 °C
Ambient temperature range	+10/+43 °C
Software variant	F51
K-Value	0.31 W/(m ² *K)
ATEX Marking	II 3G Ex nA nC nL IIB T2 Gc
ATEX certificate	-
Refrigerant	R404A
Refrigerant charge	230 g
Refrigeration capacity at -25 °C	616 Watt
GWP – CO ₂ e	902.06
Energy consumption	N/A
Heat emission 100 %	N/A
Heat emission default setpoint	N/A
Nominal consumption	580 Watt
Start current	19.6A
Sound level	-

BioPlus ER600W H – with dual compressor and solid door

Technical specifications	Data
Temperature range	-2/+20 °C
Ambient temperature range	+10/+43 °C
Software variant	M5+
K-Value	0.31 W/(m ² *K)
ATEX Marking	II 3G Ex nA nC nL IIB T2 Gc
ATEX certificate	-
Refrigerant	R134a
Refrigerant charge	2 x 215 g
Refrigeration capacity at -10 °C	2 x 314 Watt
GWP – CO ₂ e	614.9
Energy consumption	N/A
Heat emission 100 %	65 Watt
Heat emission default setpoint	N/A
Nominal consumption	538 Watt
Start current	-
Sound level	-

BioPlus ER600W H – with dual compressor and glass door

Technical specifications	Data
Temperature range	-2/+20 °C
Ambient temperature range	+10/+38 °C
Software variant	M5+
K-Value	0.5563 W/(m2*K)
ATEX Marking	II 3G Ex nA nC nL IIB T2 Gc
ATEX certificate	-
Refrigerant	R134a
Refrigerant charge	2 x 215 g
Refrigeration capacity at -10 °C	2 x 314 Watt
GWP – CO2e	614.9
Energy consumption	2.79 kWh/24h
Heat emission 100 %	499 Watt
Heat emission default setpoint	116 Watt
Nominal consumption	538 Watt
Start current	11.4A
Sound level	-

BioPlus RF600W H – with dual compressor and solid door

Technical specifications	Data
Temperature range	-25/-5 °C
Ambient temperature range	+10/+43 °C
Software variant	F51
K-Value	0.31 W/(m2*K)
ATEX Marking	II 3G Ex nA nC nL IIB T2 Gc
ATEX certificate	-
Refrigerant	R404A
Refrigerant charge	2 x 197 g
Refrigeration capacity at -25 °C	2 x 616 Watt
GWP – CO2e	1545,268
Energy consumption	6.448 kWh/24h
Heat emission 100 %	903 Watt
Heat emission default setpoint	269 Watt
Nominal consumption	1072 Watt
Start current	19.6A
Sound level	-



BioPlus ER600W G - with solid door

Technical specifications	Data
Temperature range	-2/+20 °C
Ambient temperature range	+10/+43 °C
Software variant	M5+
K-Value	0.31 W/(m ² *K)
ATEX Marking	II 3G Ex nA nC nL IIB T2 Gc
ATEX certificate	-
Refrigerant	R290
Refrigerant charge	102 g
Refrigeration capacity at -10 °C	389 Watt
GWP - CO ₂ e	0.3366
Energy consumption	1.35 kWh/24h
Heat emission 100 %	322.75 Watt
Heat emission default setpoint	56 Watt
Nominal consumption	320 Watt
Start current	9.7A
Sound level	44.8 dB(A)

BioPlus ER600W G - with glass door

Technical specifications	Data
Temperature range	-2/+20 °C
Ambient temperature range	+10/+38 °C
Software variant	M5+
K-Value	0.5563 W/(m ² *K)
ATEX Marking	II 3G Ex nA nC nL IIB T2 Gc
ATEX certificate	-
Refrigerant	R290
Refrigerant charge	102 g
Refrigeration capacity at -10 °C	389 Watt
GWP - CO ₂ e	0.3366
Energy consumption	1.65 kWh/24h
Heat emission 100 %	317.18 Watt
Heat emission default setpoint	69 Watt
Nominal consumption	320 Watt
Start current	9.7A
Sound level	44.8 dB(A)

BioPlus RF600W G
- with solid door

Technical specifications	Data
Temperature range	-25/-5 °C
Ambient temperature range	+10/+43 °C
Software variant	F51
K-Value	0.31 W/(m ² *K)
ATEX Marking	II 3G Ex nA nC nL IIB T2 Gc
ATEX certificate	-
Refrigerant	R290
Refrigerant charge	92 g
Refrigeration capacity at -25 °C	512 Watt
GWP - CO ₂ e	0.3036
Energy consumption	4.07 kWh/24h
Heat emission 100 %	444 Watt
Heat emission default setpoint	169 Watt
Nominal consumption	482 Watt
Start current	13.1A
Sound level	45.8 dB(A)





BioPlus ER600W G – with dual compressor and solid door

Technical specifications	Data
Temperature range	-2/+20 °C
Ambient temperature range	+10/+43 °C
Software variant	M5+
K-Value	0.31 W/(m ² *K)
ATEX Marking	II 3G Ex nA nC nL IIB T2 Gc
ATEX certificate	-
Refrigerant	R290
Refrigerant charge	2 x 85 g
Refrigeration capacity at -10 °C	2 x 389 Watt
GWP – CO ₂ e	0.627
Energy consumption	1.953 kWh/24h
Heat emission 100 %	561 Watt
Heat emission default setpoint	81 Watt
Nominal consumption	572 Watt
Start current	9.7A
Sound level	-

BioPlus ER600W G – with dual compressor and glass door

Technical specifications	Data
Temperature range	-2/+20 °C
Ambient temperature range	+10/+38 °C
Software variant	M5+
K-Value	0.5563 W/(m ² *K)
ATEX Marking	II 3G Ex nA nC nL IIB T2 Gc
ATEX certificate	-
Refrigerant	R290
Refrigerant charge	2 x 85 g
Refrigeration capacity at -10 °C	2 x 389 Watt
GWP – CO ₂ e	0.627
Energy consumption	2.586 kWh/24h
Heat emission 100 %	550.5 Watt
Heat emission default setpoint	108 Watt
Nominal consumption	572 Watt
Start current	9.7A
Sound level	-



BioPlus RF600W G – with dual compressor and solid door

Technical specifications	Data
Temperature range	-25/-5 °C
Ambient temperature range	+10/+43 °C
Software variant	F51
K-Value	0.31 W/(m ² *K)
ATEX Marking	II 3G Ex nA nC nL IIB T2 Gc
ATEX certificate	-
Refrigerant	R290
Refrigerant charge	2 x 100 g
Refrigeration capacity at -25 °C	2 x 512 Watt
GWP – CO ₂ e	0.66
Energy consumption	5.815 kWh/24h
Heat emission 100 %	806 Watt
Heat emission default setpoint	242 Watt
Nominal consumption	876 Watt
Start current	13.1A
Sound level	-

BioPlus 660D



General data – BioPlus 660D

Technical specifications	Data
Connection	230 VAC/50 Hz
Control Unit	Gram Control Unit with voltage-free contact, E-sensor, dry cooling and calibration function
Alarms	Acoustic and visual, High/Low temperature alarms and door alarm
Alarm ports	Voltage-free contact
Access port	1 pc. ø24.5 mm
Gross volume	660 litres
Net volume	484 litres
Door	Left or right hinged
Material interior	Stainless steel
Materiale exterior	White lacquered steel or stainless steel
Insulation	60 mm polyurethane with HFC-free cyclopentane propellant
Dimensions – W x D x H	695 x 876 x 2025/2275 mm
Air system	BioLine ventilated air distribution system
Defrost system	Automatic smart defrost with re-evaporation of defrost water
IP class	IP21

BioPlus ER660D H - with solid door

Technical specifications	Data
Temperature range	-2/+20 °C
Ambient temperature range	+10/+43 °C
Software variant	M5+
K-Value	0.31 W/(m ² *K)
ATEX Marking	II 3G Ex nA nC nL IIB T2 Gc
ATEX certificate	-
Refrigerant	R134a
Refrigerant charge	230 g
Refrigeration capacity at -10 °C	314 Watt
GWP - CO ₂ e	328.9
Energy consumption	1.32 kWh/24h
Heat emission 100 %	313 Watt
Heat emission default setpoint	55 Watt
Nominal consumption	306 Watt
Start current	11.4A
Sound level	-

BioPlus ER660D H - with glass door

Technical specifications	Data
Temperature range	-2/+20 °C
Ambient temperature range	+10/+38 °C
Software variant	M5+
K-Value	0.5223 W/(m ² *K)
ATEX Marking	II 3G Ex nA nC nL IIB T2 Gc
ATEX certificate	-
Refrigerant	R134a
Refrigerant charge	230 g
Refrigeration capacity at -10 °C	314 Watt
GWP - CO ₂ e	328.9
Energy consumption	1.84 kWh/24h
Heat emission 100 %	310 Watt
Heat emission default setpoint	77 Watt
Nominal consumption	306 Watt
Start current	11.4A
Sound level	-



BioPlus RF660D H - with solid door

Technical specifications	Data
Temperature range	-25/-5 °C
Ambient temperature range	+10/+43 °C
Software variant	F51
K-Value	0.31 W/(m ² *K)
ATEX Marking	II 3G Ex nA nC nL IIB T2 Gc
ATEX certificate	-
Refrigerant	R404A
Refrigerant charge	230 g
Refrigeration capacity at -25 °C	616 Watt
GWP - CO ₂ e	902.06
Energy consumption	4.91 kWh/24h
Heat emission 100 %	505 Watt
Heat emission default setpoint	205 Watt
Nominal consumption	580 Watt
Start current	19.6A
Sound level	-

BioPlus ER660D G - with solid door

Technical specifications	Data
Temperature range	-2/+20 °C
Ambient temperature range	+10/+43 °C
Software variant	M5+
K-Value	0.31 W/(m ² *K)
ATEX Marking	II 3G Ex nA nC nL IIB T2 Gc
ATEX certificate	-
Refrigerant	R290
Refrigerant charge	102 g
Refrigeration capacity at -10 °C	389 Watt
GWP - CO ₂ e	0.3366
Energy consumption	1.18 kWh/24h
Heat emission 100 %	317 Watt
Heat emission default setpoint	49 Watt
Nominal consumption	320 Watt
Start current	9.7A
Sound level	45.9 dB(A)

BioPlus ER660D G - with glass door

Technical specifications	Data
Temperature range	-2/+20 °C
Ambient temperature range	+10/+38 °C
Software variant	M5+
K-Value	0.5223 W/(m ² *K)
ATEX Marking	II 3G Ex nA nC nL IIB T2 Gc
ATEX certificate	-
Refrigerant	R290
Refrigerant charge	102 g
Refrigeration capacity at -10 °C	389 Watt
GWP - CO ₂ e	0.3366
Energy consumption	1.69 kWh/24h
Heat emission 100 %	317 Watt
Heat emission default setpoint	70 Watt
Nominal consumption	320 Watt
Start current	9.7A
Sound level	45.9 dB(A)



BioPlus RF660D G - with solid door

Technical specifications	Data
Temperature range	-25/-5 °C
Ambient temperature range	+10/+43 °C
Software variant	F51
K-Value	0.31 W/(m ² *K)
ATEX Marking	II 3G Ex nA nC nL IIB T2 Gc
ATEX certificate	-
Refrigerant	R290
Refrigerant charge	92 g
Refrigeration capacity at -25 °C	512 Watt
GWP - CO ₂ e	0.3036
Energy consumption	4.23 kWh/24h
Heat emission 100 %	444 Watt
Heat emission default setpoint	176 Watt
Nominal consumption	482 Watt
Start current	13.1A
Sound level	45.6 dB(A)

BioPlus 660W

General data – BioPlus 660W

Technical specifications	Data
Connection	230 VAC/50 Hz
Control Unit	Gram Control Unit with voltage-free contact, E-sensor, dry cooling and calibration function
Alarms	Acoustic and visual, High/Low temperature alarms and door alarm
Alarm ports	Voltage-free contact
Access port	1 pc. ø24.5 mm
Gross volume	660 litres
Net volume	484 litres
Door	Left or right hinged
Material interior	Stainless steel
Materiale exterior	White lacquered steel or stainless steel
Insulation	60 mm polyurethane with HFC-free cyclopentane propellant
Dimensions – W x D x H	815 x 756 x 2025/2275 mm
Air system	BioLine ventilated air distribution system
Defrost system	Automatic smart defrost with re-evaporation of defrost water
IP class	IP21



BioPlus ER660W H - with solid door

Technical specifications	Data
Temperature range	-2/+20 °C
Ambient temperature range	+10/+43 °C
Software variant	M5+
K-Value	0.31 W/(m ² *K)
ATEX Marking	II 3G Ex nA nC nL IIB T2 Gc
ATEX certificate	-
Refrigerant	R134a
Refrigerant charge	230 g
Refrigeration capacity at -10 °C	314 Watt
GWP - CO ₂ e	328.9
Energy consumption	1.42 kWh/24h
Heat emission 100 %	313 Watt
Heat emission default setpoint	59 Watt
Nominal consumption	306 Watt
Start current	11.4A
Sound level	-

BioPlus ER660W H - with glass door

Technical specifications	Data
Temperature range	-2/+20 °C
Ambient temperature range	+10/+38 °C
Software variant	M5+
K-Value	0.5604 W/(m ² *K)
ATEX Marking	II 3G Ex nA nC nL IIB T2 Gc
ATEX certificate	-
Refrigerant	R134a
Refrigerant charge	230 g
Refrigeration capacity at -10 °C	314 Watt
GWP - CO ₂ e	328.9
Energy consumption	1.90 kWh/24h
Heat emission 100 %	307 Watt
Heat emission default setpoint	79 Watt
Nominal consumption	306 Watt
Start current	11.4A
Sound level	-

BioPlus RF660W H
- with solid door

Technical specifications	Data
Temperature range	-25/-5 °C
Ambient temperature range	+10/+43 °C
Software variant	F51
K-Value	0.31 W/(m ² *K)
ATEX Marking	II 3G Ex nA nC nL IIB T2 Gc
ATEX certificate	-
Refrigerant	R404A
Refrigerant charge	230 g
Refrigeration capacity at -25 °C	616 Watt
GWP - CO ₂ e	902.06
Energy consumption	5.07 kWh/24h
Heat emission 100 %	497 Watt
Heat emission default setpoint	211 Watt
Nominal consumption	580 Watt
Start current	19.6A
Sound level	-



BioPlus ER660W H – with dual compressor and solid door

Technical specifications	Data
Temperature range	-2/+20 °C
Ambient temperature range	+10/+43 °C
Software variant	M5+
K-Value	0.31 W/(m ² *K)
ATEX Marking	II 3G Ex nA nC nL IIB T2 Gc
ATEX certificate	-
Refrigerant	R134a
Refrigerant charge	2 x 215 g
Refrigeration capacity at -10 °C	2 x 314 Watt
GWP – CO ₂ e	614.9
Energy consumption	2.26 kWh/24h
Heat emission 100 %	500 Watt
Heat emission default setpoint	94 Watt
Nominal consumption	538 Watt
Start current	11.4A
Sound level	-

BioPlus ER660W H – with dual compressor and glass door

Technical specifications	Data
Temperature range	-2/+20 °C
Ambient temperature range	+10/+38 °C
Software variant	M5+
K-Value	0.5604 W/(m ² *K)
ATEX Marking	II 3G Ex nA nC nL IIB T2 Gc
ATEX certificate	-
Refrigerant	R134a
Refrigerant charge	2 x 215 g
Refrigeration capacity at -10 °C	2 x 314 Watt
GWP – CO ₂ e	614.9
Energy consumption	N/A
Heat emission 100 %	65
Heat emission default setpoint	N/A
Nominal consumption	538 Watt
Start current	11.4A
Sound level	-



BioPlus RF660W H – with dual compressor and solid door

Technical specifications	Data
Temperature range	-25/-5 °C
Ambient temperature range	+10/+43 °C
Software variant	F51
K-Value	0.31 W/(m ² *K)
ATEX Marking	II 3G Ex nA nC nL IIB T2 Gc
ATEX certificate	-
Refrigerant	R404A
Refrigerant charge	2 x 197 g
Refrigeration capacity at -25 °C	2 x 616 Watt
GWP – CO ₂ e	1545.268
Energy consumption	6.77 kWh/24h
Heat emission 100 %	963 Watt
Heat emission default setpoint	282 Watt
Nominal consumption	1072 Watt
Start current	19.6A
Sound level	-



BioPlus ER660W G - with solid door

Technical specifications	Data
Temperature range	-2/+20 °C
Ambient temperature range	+10/+43 °C
Software variant	M5+
K-Value	0.31 W/(m ² *K)
ATEX Marking	II 3G Ex nA nC nL IIB T2 Gc
ATEX certificate	-
Refrigerant	R290
Refrigerant charge	102 g
Refrigeration capacity at -10 °C	389 Watt
GWP - CO ₂ e	0.3366
Energy consumption	1.28 kWh/24h
Heat emission 100 %	316 Watt
Heat emission default setpoint	53 Watt
Nominal consumption	320 Watt
Start current	9.7A
Sound level	44.8 dB(A)

BioPlus ER660W G - with glass door

Technical specifications	Data
Temperature range	-2/+20 °C
Ambient temperature range	+10/+38 °C
Software variant	M5+
K-Value	0.5604 W/(m ² *K)
ATEX Marking	II 3G Ex nA nC nL IIB T2 Gc
ATEX certificate	-
Refrigerant	R290
Refrigerant charge	102 g
Refrigeration capacity at -10 °C	389 Watt
GWP - CO ₂ e	0.3366
Energy consumption	1.78 kWh/24h
Heat emission 100 %	320 Watt
Heat emission default setpoint	74 Watt
Nominal consumption	320 Watt
Start current	9.7A
Sound level	44.8 dB(A)

BioPlus RF660W G
- with solid door

Technical specifications	Data
Temperature range	-25 °C/-50 °C
Ambient temperature range	+10/+43 °C
Software variant	F51
K-Value	0.31 W/(m ² *K)
ATEX Marking	II 3G Ex nA nC nL IIB T2 Gc
ATEX certificate	-
Refrigerant	R290
Refrigerant charge	92 g
Refrigeration capacity at -25 °C	512 Watt
GWP - CO ₂ e	N/A
Energy consumption	4.46 kWh/24h
Heat emission 100 %	447 Watt
Heat emission default setpoint	186 Watt
Nominal consumption	482 Watt
Start current	13.1A
Sound level	49.3 dB(A)





BioPlus ER660W G – with dual compressor and solid door

Technical specifications	Data
Temperature range	-2/+20 °C
Ambient temperature range	+10/+43 °C
Software variant	M5+
K-Value	0.31 W/(m ² *K)
ATEX Marking	II 3G Ex nA nC nL IIB T2 Gc
ATEX certificate	-
Refrigerant	R290
Refrigerant charge	2 x 85 g
Refrigeration capacity at -10 °C	2 x 389 Watt
GWP – CO ₂ e	0.627
Energy consumption	2.20 kWh/24h
Heat emission 100 %	551 Watt
Heat emission default setpoint	92 Watt
Nominal consumption	572 Watt
Start current	9.7A
Sound level	-

BioPlus ER660W G – with dual compressor and glass door

Technical specifications	Data
Temperature range	-2/+20 °C
Ambient temperature range	+10/+38 °C
Software variant	M5+
K-Value	0.5604 W/(m ² *K)
ATEX Marking	II 3G Ex nA nC nL IIB T2 Gc
ATEX certificate	-
Refrigerant	R290
Refrigerant charge	2 x 85 g
Refrigeration capacity at -10 °C	2 x 389 Watt
GWP – CO ₂ e	0.627
Energy consumption	2.175 kWh/24h
Heat emission 100 %	556 Watt
Heat emission default setpoint	113 Watt
Nominal consumption	572 Watt
Start current	9.7A
Sound level	-



BioPlus RF660W G – with dual compressor and solid door

Technical specifications	Data
Temperature range	-25 °C/-5 °C
Ambient temperature range	+10/+43 °C
Software variant	F51
K-Value	0.31 W/(m ² *K)
ATEX Marking	II 3G Ex nA nC nL IIB T2 Gc
ATEX certificate	-
Refrigerant	R290
Refrigerant charge	2 x 100 g
Refrigeration capacity at -25 °C	2 x 512 Watt
GWP – CO ₂ e	0.66
Energy consumption	6.02 kWh/24h
Heat emission 100 %	821 Watt
Heat emission default setpoint	251 Watt
Nominal consumption	876 Watt
Start current	13.1A
Sound level	-

BioPlus EF600W

General data – BioPlus EF600W

Technical specifications	Data
Connection	230 VAC/50 Hz
Control Unit	Gram Control Unit with voltage-free contact, E-sensor and offset function
Alarms	Acoustic and visual, High/Low temperature alarms and door alarm
Alarm ports	Voltage-free contact
Access port	1 pc. ø24.5 mm
Gross volume	600 litres
Net volume	432 litres
Door	Left or right hinged
Material interior	Stainless steel and inner doors in PMMA
Materiale exterior	White lacquered steel or stainless steel
Insulation	60 mm polyurethane with HFC-free cyclopentane propellant
Dimensions – W x D x H	837 x 756 x 1875/2125 mm
Air system	BioLine ventilated air distribution system
Defrost system	Automatic smart defrost with re-evaporation of defrost water
IP class	IP21

BioPlus EF600W H – with solid door

Technical specifications	Data
Temperature range	-35/-5 °C
Ambient temperature range	+10/+30 °C
Software variant	E1+
K-Value	0.31 W/(m ² *K)
ATEX Marking	II 3G Ex nA nC nL IIB T2 Gc
ATEX certificate	-
Refrigerant	R404A
Refrigerant charge	360 g
Refrigeration capacity at -40 °C	313 Watt
GWP – CO ₂ e	1411.92
Energy consumption	9.13 kWh/24h
Heat emission 100 %	477 Watt
Heat emission default setpoint	380 Watt
Nominal consumption	474 Watt
Start current	20A
Sound level	-

BioPlus EF600W H – water cooled, with solid door

Technical specifications	Data
Temperature range	-35/-5 °C
Ambient temperature range	+10/+30 °C
Software variant	E1+
K-Value	0.31 W/(m ² *K)
ATEX Marking	II 3G Ex nA nC nL IIB T3 Gc
ATEX certificate	-
Refrigerant	R404A
Refrigerant charge	230 g
Refrigeration capacity at -40 °C	355 Watt
GWP – CO ₂ e	902,06
Energy consumption	7.93 kWh/24h
Heat emission 100 %	523 Watt
Heat emission default setpoint	330 Watt
Nominal consumption	494 Watt
Start current	20A
Sound level	-



BioPlus EF600W H – with dual compressor and solid door

Technical specifications	Data
Temperature range	-35/-5 °C
Ambient temperature range	+10/+30 °C
Software variant	E1+
K-Value	0.31 W/(m ² *K)
ATEX Marking	II 3G Ex nA nC nL IIB T3 Gc
ATEX certificate	-
Refrigerant	R404A
Refrigerant charge	2 x 197 g
Refrigeration capacity at -40 °C	2 x 616 Watt
GWP – CO ₂ e	1545,268
Energy consumption	12.70 kWh/24h
Heat emission 100 %	830 Watt
Heat emission default setpoint	529 Watt
Nominal consumption	748 Watt
Start current	19.6A
Sound level	-

BioPlus EF600W G
- with solid door

Technical specifications	Data
Temperature range	-35/-5 °C
Ambient temperature range	+10/+30 °C
Software variant	E1+
K-Value	0.31 W/(m ² *K)
ATEX Marking	II 3G Ex nA nC nL IIB T2 Gc
ATEX certificate	-
Refrigerant	R290
Refrigerant charge	92 g
Refrigeration capacity at -40 °C	244 Watt
GWP - CO ₂ e	0.3036
Energy consumption	8.86 kWh/24h
Heat emission 100 %	442 Watt
Heat emission default setpoint	369 Watt
Nominal consumption	402 Watt
Start current	19.5A
Sound level	-

BioPlus EF600W G
- water cooled, with solid door

Technical specifications	Data
Temperature range	-35/-5 °C
Ambient temperature range	+10/+30 °C
Software variant	E1+
K-Value	0.31 W/(m ² *K)
ATEX Marking	II 3G Ex nA nC nL IIB T3 Gc
ATEX certificate	-
Refrigerant	-
Refrigerant charge	N/A
Refrigeration capacity at -40 °C	-
GWP - CO ₂ e	N/A
Energy consumption	N/A
Heat emission 100 %	N/A
Heat emission default setpoint	N/A
Nominal consumption	N/A
Start current	-
Sound level	-



BioPlus EF600W G – with dual compressor and solid door

Technical specifications	Data
Temperature range	-35/-5 °C
Ambient temperature range	+10/+30 °C
Software variant	E1+
K-Value	0.31 W/(m ² *K)
ATEX Marking	II 3G Ex nA nC nL IIB T3 Gc
ATEX certificate	-
Refrigerant	R290
Refrigerant charge	2 x 94 g
Refrigeration capacity at -40 °C	2 x 286 Watt
GWP – CO ₂ e	0.594
Energy consumption	12.544 kWh/24h
Heat emission 100 %	828 Watt
Heat emission default setpoint	523 Watt
Nominal consumption	746 Watt
Start current	14.8A
Sound level	-

BioPlus EF660W

General data – BioPlus EF660W

Technical specifications	Data
Connection	230 VAC, 50 Hz
Control Unit	Gram Control Unit with voltage-free contact, E-sensor and offset function
Alarms	Acoustic and visual, High/Low temperature alarms and door alarm
Alarm ports	Voltage-free contact
Access port	1 pc. ø24.5 mm
Gross volume	660 litres
Net volume	484 litres
Door	Left or right hinged
Material interior	Stainless steel and inner doors in PMMA
Materiale exterior	White lacquered steel or stainless steel
Insulation	60 mm polyurethane with HFC-free cyclopentane propellant
Dimensions – W x D x H	837 x 756 x 2025/2275 mm
Air system	BioLine ventilated air distribution system
Defrost system	Automatic smart defrost with re-evaporation of defrost water
IP class	IP21



BioPlus EF660W H - with solid door

Technical specifications	Data
Temperature range	-35/-5 °C
Ambient temperature range	+10/+30 °C
Software variant	E1+
K-Value	0.31 W/m ² K
ATEX Marking	II 3G Ex nA nC nL IIB T2 Gc
ATEX certificate	-
Refrigerant	R404A
Refrigerant charge	360 g
Refrigeration capacity at -40 °C	313 Watt
GWP - CO ₂ e	1411.92
Energy consumption	9.46 kWh/24h
Heat emission 100 %	490 Watt
Heat emission default setpoint	394 Watt
Nominal consumption	474 Watt
Start current	20A
Sound level	-

BioPlus EF660W H - with dual compressor and solid door

Technical specifications	Data
Temperature range	-35/-5 °C
Ambient temperature range	+10/+30 °C
Software variant	E1+
K-Value	0.31 W/m ² K
ATEX Marking	II 3G Ex nA nC nL IIB T2 Gc
ATEX certificate	-
Refrigerant	R404A
Refrigerant charge	2 x 197 g
Refrigeration capacity at -40 °C	2 x 247 Watt
GWP - CO ₂ e	1545.268
Energy consumption	12.92 kWh/24h
Heat emission 100 %	963 Watt
Heat emission default setpoint	538 Watt
Nominal consumption	748 Watt
Start current	19.6A
Sound level	-

BioPlus EF660W G – with solid door

Technical specifications	Data
Temperature range	-35/-5 °C
Ambient temperature range	+10/+30 °C
Software variant	E1+
K-Value	0.31 W/m ² K
ATEX Marking	II 3G Ex nA nC nL IIB T2 Gc
ATEX certificate	-
Refrigerant	R290
Refrigerant charge	92 g
Refrigeration capacity at -40 °C	244 Watt
GWP – CO ₂ e	N/A
Energy consumption	9.02 kWh/24h
Heat emission 100 %	447 Watt
Heat emission default setpoint	376 Watt
Nominal consumption	437 Watt
Start current	19.5A
Sound level	55.3 dB(A)

BioPlus EF660W G – with dual compressor and solid door

Technical specifications	Data
Temperature range	-35/-5 °C
Ambient temperature range	+10/+30 °C
Software variant	E1+
K-Value	0.31 W/m ² K
ATEX Marking	II 3G Ex nA nC nL IIB T2 Gc
ATEX certificate	-
Refrigerant	R290
Refrigerant charge	394 g
Refrigeration capacity at -40 °C	572 Watt
GWP – CO ₂ e	N/A
Energy consumption	12.87 kWh/24h
Heat emission 100 %	839 Watt
Heat emission default setpoint	536 Watt
Nominal consumption	746 Watt
Start current	14.85A
Sound level	49 dB(A)

BioPlus 930

General data – BioPlus 930

Technical specifications	Data
Connection	230 VAC/50 Hz
Control Unit	Gram Control Unit with voltage-free contact, E-sensor, dry cooling and offset function
Alarms	Acoustic and visual, High/Low temperature alarms and door alarm
Alarm ports	Voltage-free contact
Access port	1 pc. ø24.5 mm
Gross volume	930 litres
Net volume	702 litres
Door	Left or right hinged
Material interior	Stainless steel
Materiale exterior	White lacquered steel or stainless steel
Insulation	60 mm polyurethane with HFC-free cyclopentane propellant
Dimensions – W x D x H	780 x 1045 x 2025/2275 mm
Air system	BioLine ventilated air distribution system
Defrost system	Automatic smart defrost with re-evaporation of defrost water
IP class	IP21

BioPlus ER930 H - with solid door

Technical specifications	Data
Temperature range	-2/+20 °C
Ambient temperature range	+10/+43 °C
Software variant	M5+
K-Value	0.31 W/(m ² *K)
ATEX Marking	II 3G Ex nA nC nL IIB T2 Gc
ATEX certificate	-
Refrigerant	R134a
Refrigerant charge	400 g
Refrigeration capacity at -10 °C	487 Watt
GWP - CO ₂ e	572
Energy consumption	2.79 kWh/24h
Heat emission 100 %	446 Watt
Heat emission default setpoint	116 Watt
Nominal consumption	480 Watt
Start current	15A
Sound level	-

BioPlus ER930 H - with glass door

Technical specifications	Data
Temperature range	-2/+20 °C
Ambient temperature range	+10/+38 °C
Software variant	M5+
K-Value	0.509 W/(m ² *K)
ATEX Marking	II 3G Ex nA nC nL IIB T2 Gc
ATEX certificate	-
Refrigerant	R134a
Refrigerant charge	400 g
Refrigeration capacity at -10 °C	487 Watt
GWP - CO ₂ e	572
Energy consumption	2.80 kWh/24h
Heat emission 100 %	423 Watt
Heat emission default setpoint	117 Watt
Nominal consumption	480 Watt
Start current	15A
Sound level	-



BioPlus RF930 H - with solid door

Technical specifications	Data
Temperature range	-25/-5 °C
Ambient temperature range	+10/+43 °C
Software variant	F51
K-Value	0.31 W/(m ² *K)
ATEX Marking	II 3G Ex nA nC nL IIB T2 Gc
ATEX certificate	-
Refrigerant	R404A
Refrigerant charge	300 g
Refrigeration capacity at -25 °C	714 Watt
GWP - CO ₂ e	1176.6
Energy consumption	6.28 kWh/24h
Heat emission 100 %	668 Watt
Heat emission default setpoint	262 Watt
Nominal consumption	776 Watt
Start current	18.6A
Sound level	49.9 dB(A)

BioPlus ER930 G - with solid door

Technical specifications	Data
Temperature range	-2/+20 °C
Ambient temperature range	+10/+43 °C
Software variant	M5+
K-Value	0.31 W/(m ² *K)
ATEX Marking	II 3G Ex nA nC nL IIB T2 Gc
ATEX certificate	-
Refrigerant	R290
Refrigerant charge	126 g
Refrigeration capacity at -10 °C	627 Watt
GWP - CO ₂ e	0.4158
Energy consumption	2.10 kWh/24h
Heat emission 100 %	420 Watt
Heat emission default setpoint	88 Watt
Nominal consumption	457 Watt
Start current	10.4A
Sound level	-

BioPlus ER930 G - with glass door

Technical specifications	Data
Temperature range	-2/+20 °C
Ambient temperature range	+10/+38° C
Software variant	M5+
K-Value	0.509 W/(m ² *K)
ATEX Marking	II 3G Ex nA nC nL IIB T2 Gc
ATEX certificate	-
Refrigerant	R290
Refrigerant charge	126 g
Refrigeration capacity at -10 °C	627 Watt
GWP - CO ₂ e	0.4158
Energy consumption	2.81 kWh/24h
Heat emission 100 %	421 Watt
Heat emission default setpoint	117 Watt
Nominal consumption	457 Watt
Start current	10.4A
Sound level	-



BioPlus RF930 G - with solid door

Technical specifications	Data
Temperature range	-25/-5 °C
Ambient temperature range	+10/+43 °C
Software variant	F51
K-Value	0.31 W/(m ² *K)
ATEX Marking	II 3G Ex nA nC nL IIB T2 Gc
ATEX certificate	-
Refrigerant	R290
Refrigerant charge	90 g
Refrigeration capacity at -25 °C	828 Watt
GWP - CO ₂ e	0.297
Energy consumption	7.25 kWh/24h
Heat emission 100 %	675 Watt
Heat emission default setpoint	255 Watt
Nominal consumption	830.5 Watt
Start current	23.5A
Sound level	-

BioPlus 1270

General data – BioPlus 1270

Technical specifications	Data
Connection	230 VAC/50 Hz
Control Unit	Gram Control Unit with voltage-free contact, E-sensor, dry cooling and offset function
Alarms	Acoustic and visual, High/Low temperature alarms and door alarm
Alarm ports	Voltage-free contact
Access port	1 pc. ø24.5 mm
Gross volume	1270 litres
Net volume	864 litres
Door	One left hinged and one right hinged
Material interior	Stainless steel
Material exterior	White lacquered steel or stainless steel
Insulation	60 mm polyurethane with HFC-free cyclopentane propellant
Dimensions – W x D x H	1390 x 876 x 1875/2125 mm
Air system	BioLine ventilated air distribution system
Defrost system	Automatic smart defrost with re-evaporation of defrost water
IP class	IP21



BioPlus ER1270 H - with solid door

Technical specifications	Data
Temperature range	-2/+20 °C
Ambient temperature range	+10/+43 °C
Software variant	M5+
K-Value	0.31 W/(m ² *K)
ATEX Marking	II 3G Ex nA nC nL IIB T3 Gc
ATEX certificate	-
Refrigerant	R134a
Refrigerant charge	355 g
Refrigeration capacity at -10 °C	703 Watt
GWP - CO ₂ e	507.65
Energy consumption	2.85 kWh/24h
Heat emission 100 %	578 Watt
Heat emission default setpoint	119 Watt
Nominal consumption	570 Watt
Start current	14.8A
Sound level	-

BioPlus ER1270 H - with glass door

Technical specifications	Data
Temperature range	-2/+20 °C
Ambient temperature range	+10/+38° C
Software variant	M5+
K-Value	0.5752 W/(m ² *K)
ATEX Marking	II 3G Ex nA nC nL IIB T3 Gc
ATEX certificate	-
Refrigerant	R134a
Refrigerant charge	355 g
Refrigeration capacity at -10 °C	703 Watt
GWP - CO ₂ e	507.65
Energy consumption	3.39 kWh/24h
Heat emission 100 %	578 Watt
Heat emission default setpoint	141 Watt
Nominal consumption	570 Watt
Start current	14.8A
Sound level	-

BioPlus RF1270 H
- with solid door

Technical specifications	Data
Temperature range	-25/-5 °C
Ambient temperature range	+10/+43 °C
Software variant	F51
K-Value	0.31 W/(m ² *K)
ATEX Marking	II 3G Ex nA nC nL IIB T3 Gc
ATEX certificate	-
Refrigerant	R404A
Refrigerant charge	420 g
Refrigeration capacity at -25 °C	947 Watt
GWP - CO ₂ e	1647.24
Energy consumption	7.48 kWh/24h
Heat emission 100 %	778 Watt
Heat emission default setpoint	312 Watt
Nominal consumption	844 Watt
Start current	14.8A
Sound level	-





BioPlus ER1270 H – with dual compressor and solid door

Technical specifications	Data
Temperature range	-2/+20 °C
Ambient temperature range	+10/+43 °C
Software variant	M5+
K-Value	0.31 W/(m ² *K)
ATEX Marking	II 3G Ex nA nC nL IIB T3 Gc
ATEX certificate	-
Refrigerant	R134a
Refrigerant charge	2 x 215 g
Refrigeration capacity at -10 °C	2 x 703 Watt
GWP – CO ₂ e	614.9
Energy consumption	N/A
Heat emission 100 %	N/A
Heat emission default setpoint	N/A
Nominal consumption	1040 Watt
Start current	14.8A
Sound level	-

BioPlus ER1270 H – with dual compressor and glass door

Technical specifications	Data
Temperature range	-2/+20 °C
Ambient temperature range	+10/+38° C
Software variant	M5+
K-Value	0.5752 W/(m ² *K)
ATEX Marking	II 3G Ex nA nC nL IIB T3 Gc
ATEX certificate	-
Refrigerant	R134a
Refrigerant charge	2 x 215 g
Refrigeration capacity at -10 °C	2 x 703 Watt
GWP – CO ₂ e	614,9
Energy consumption	5.09 kWh/24h
Heat emission 100 %	468 Watt
Heat emission default setpoint	212 Watt
Nominal consumption	1040 Watt
Start current	14.8A
Sound level	-



BioPlus RF1270 H – with dual compressor and solid door

Technical specifications	Data
Temperature range	-25/-5 °C
Ambient temperature range	+10/+43 °C
Software variant	F51
K-Value	0.31 W/(m ² *K)
ATEX Marking	II 3G Ex nA nC nL IIB T3 Gc
ATEX certificate	-
Refrigerant	R404A
Refrigerant charge	2 x 220 g
Refrigeration capacity at -25 °C	2 x 616 Watt
GWP – CO ₂ e	1725,68
Energy consumption	8.89 kWh/24h
Heat emission 100 %	1048 Watt
Heat emission default setpoint	370 Watt
Nominal consumption	1118 Watt
Start current	19.6A
Sound level	-



BioPlus ER1270 G - with solid door

Technical specifications	Data
Temperature range	-2/+20 °C
Ambient temperature range	+10/+43 °C
Software variant	M5+
K-Value	0.31 W/(m ² *K)
ATEX Marking	II 3G Ex nA nC nL IIB T3 Gc
ATEX certificate	-
Refrigerant	R290
Refrigerant charge	110 g
Refrigeration capacity at -10 °C	946 Watt
GWP - CO ₂ e	0.363
Energy consumption	2.50 kWh/24h
Heat emission 100 %	530 Watt
Heat emission default setpoint	104 Watt
Nominal consumption	586 Watt
Start current	13.2A
Sound level	48.3 dB(A)

BioPlus ER1270 G - with glass door

Technical specifications	Data
Temperature range	-2/+20 °C
Ambient temperature range	+10/+38° C
Software variant	M5+
K-Value	0.5752 W/(m ² *K)
ATEX Marking	II 3G Ex nA nC nL IIB T3 Gc
ATEX certificate	-
Refrigerant	R290
Refrigerant charge	110 g
Refrigeration capacity at -10 °C	946 Watt
GWP - CO ₂ e	0.363
Energy consumption	3.48 kWh/24h
Heat emission 100 %	540 Watt
Heat emission default setpoint	145 Watt
Nominal consumption	586 Watt
Start current	13.2A
Sound level	48.3 dB(A)

BioPlus RF1270 G
- with solid door

Technical specifications	Data
Temperature range	-25/-5 °C
Ambient temperature range	+10/+43 °C
Software variant	F51
K-Value	0.31 W/(m ² *K)
ATEX Marking	II 3G Ex nA nC nL IIB T3 Gc
ATEX certificate	-
Refrigerant	R290
Refrigerant charge	2 x 85 g
Refrigeration capacity at -25 °C	2 x 475 Watt
GWP - CO ₂ e	0.561
Energy consumption	7.97 kWh/24h
Heat emission 100 %	828 Watt
Heat emission default setpoint	332 Watt
Nominal consumption	860 Watt
Start current	13.2A
Sound level	51 dB(A)



BioPlus ER1270 G – with dual compressor and solid door

Technical specifications	Data
Temperature range	-2/+20 °C
Ambient temperature range	+10/+43 °C
Software variant	M5+
K-Value	0.31 W/(m ² *K)
ATEX Marking	II 3G Ex nA nC nL IIB T3 Gc
ATEX certificate	-
Refrigerant	R290
Refrigerant charge	2 x 120 g
Refrigeration capacity at -10 °C	2 x 719 Watt
GWP – CO ₂ e	0.792
Energy consumption	2.61 kWh/24h
Heat emission 100 %	753 Watt
Heat emission default setpoint	109 Watt
Nominal consumption	828 Watt
Start current	13.2A
Sound level	48.3 dB(A)

BioPlus ER1270 G – with dual compressor and glass door

Technical specifications	Data
Temperature range	-2/+20 °C
Ambient temperature range	+10/+38 °C
Software variant	M5+
K-Value	0.5752 W/(m ² *K)
ATEX Marking	II 3G Ex nA nC nL IIB T3 Gc
ATEX certificate	-
Refrigerant	R290
Refrigerant charge	2 x 120 g
Refrigeration capacity at -10 °C	2 x 719 Watt
GWP – CO ₂ e	0.792
Energy consumption	2,945 kWh/24h
Heat emission 100 %	751 Watt
Heat emission default setpoint	123 Watt
Nominal consumption	828 Watt
Start current	13.2A
Sound level	48.3 dB(A)



BioPlus RF1270 G – with dual compressor and solid door

Technical specifications	Data
Temperature range	-25/-5 °C
Ambient temperature range	+10/+43 °C
Software variant	F51
K-Value	0.31 W/(m ² *K)
ATEX Marking	II 3G Ex nA nC nL IIB T3 Gc
ATEX certificate	-
Refrigerant	R290
Refrigerant charge	2 x 120 g
Refrigeration capacity at -25 °C	2 x 512 Watt
GWP – CO ₂ e	0.792
Energy consumption	7.92 kWh/24h
Heat emission 100 %	828 Watt
Heat emission default setpoint	332 Watt
Nominal consumption	930 Watt
Start current	13.1A
Sound level	-

BioPlus 1400

General data – BioPlus 1400

Technical specifications	Data
Connection	230 VAC/50 Hz
Control Unit	Gram Control Unit with voltage-free contact, E-sensor, dry cooling and offset function
Alarms	Acoustic and visual, High/Low temperature alarms and door alarm
Alarm ports	Voltage-free contact
Access port	1 pc. ø24.5 mm
Gross volume	1400 litres
Net volume	968 litres
Door	One left hinged and one right hinged
Material interior	Stainless steel
Material exterior	White lacquered steel or stainless steel
Insulation	60 mm polyurethane with HFC-free cyclopentane propellant
Dimensions – W x D x H	1390 x 876 x 2025/2275 mm
Air system	BioLine ventilated air distribution system
Defrost system	Automatic smart defrost with re-evaporation of defrost water
IP class	IP21

BioPlus ER1400 H - with solid door

Technical specifications	Data
Temperature range	-2/+20 °C
Ambient temperature range	+10/+43 °C
Software variant	M5+
K-Value	0.31 W/(m ² *K)
ATEX Marking	II 3G Ex nA nC nL IIB T3 Gc
ATEX certificate	-
Refrigerant	R134a
Refrigerant charge	355 g
Refrigeration capacity at -10 °C	703 Watt
GWP - CO ₂ e	507,65
Energy consumption	2.80 kWh/24h
Heat emission 100 %	553 Watt
Heat emission default setpoint	117 Watt
Nominal consumption	570 Watt
Start current	14.8A
Sound level	-

BioPlus ER1400 H - with glass door

Technical specifications	Data
Temperature range	-2/+20 °C
Ambient temperature range	+10/+38° C
Software variant	M5+
K-Value	0.5808 W/(m ² *K)
ATEX Marking	II 3G Ex nA nC nL IIB T3 Gc
ATEX certificate	-
Refrigerant	R134a
Refrigerant charge	355 g
Refrigeration capacity at -10 °C	703 Watt
GWP - CO ₂ e	507,65
Energy consumption	4.16kWh/24h
Heat emission 100 %	577 Watt
Heat emission default setpoint	173 Watt
Nominal consumption	570 Watt
Start current	14.8A
Sound level	-



BioPlus RF1400 H – with solid door

Technical specifications	Data
Temperature range	-25/-5 °C
Ambient temperature range	+10/+43 °C
Software variant	F51
K-Value	0.31 W/(m ² *K)
ATEX Marking	II 3G Ex nA nC nL IIB T3 Gc
ATEX certificate	-
Refrigerant	R404A
Refrigerant charge	420 g
Refrigeration capacity at -25 °C	947 Watt
GWP – CO ₂ e	1647,24
Energy consumption	8.08 kWh/24h
Heat emission 100 %	815 Watt
Heat emission default setpoint	337 Watt
Nominal consumption	844 Watt
Start current	14.8A
Sound level	-

BioPlus ER1400 H – with dual compressor and solid door

Technical specifications	Data
Temperature range	-2/+20 °C
Ambient temperature range	+10/+43 °C
Software variant	M5+
K-Value	0.31 W/(m ² *K)
ATEX Marking	II 3G Ex nA nC nL IIB T3 Gc
ATEX certificate	-
Refrigerant	R134a
Refrigerant charge	2 x 215 g
Refrigeration capacity at -10 °C	2 x 703 Watt
GWP – CO ₂ e	614.9
Energy consumption	2.83 kWh/24h
Heat emission 100 %	462 Watt
Heat emission default setpoint	118 Watt
Nominal consumption	1040 Watt
Start current	14.8A
Sound level	-

BioPlus ER1400 H – with dual compressor and glass door

Technical specifications	Data
Temperature range	-2/+20 °C
Ambient temperature range	+10/+38° C
Software variant	M5+
K-Value	0.5808 W/(m2*K)
ATEX Marking	II 3G Ex nA nC nL IIB T3 Gc
ATEX certificate	-
Refrigerant	R134a
Refrigerant charge	2 x 215 g
Refrigeration capacity at -10 °C	2 x 703 Watt
GWP – CO2e	614.9
Energy consumption	3.90 kWh/24h
Heat emission 100 %	452 Watt
Heat emission default setpoint	162 Watt
Nominal consumption	1040 Watt
Start current	14.8A
Sound level	-

BioPlus RF1400 H – with dual compressor and solid door

Technical specifications	Data
Temperature range	-25/-5 °C
Ambient temperature range	+10/+43 °C
Software variant	F51
K-Value	0.31 W/(m2*K)
ATEX Marking	II 3G Ex nA nC nL IIB T3 Gc
ATEX certificate	-
Refrigerant	R404A
Refrigerant charge	2 x 220 g
Refrigeration capacity at -25 °C	2 x 616 Watt
GWP – CO2e	1725.68
Energy consumption	8,56 kWh/24h
Heat emission 100 %	1071 Watt
Heat emission default setpoint	394 Watt
Nominal consumption	1118 Watt
Start current	14.8A
Sound level	-



BioPlus ER1400 G - with solid door

Technical specifications	Data
Temperature range	-2/+20 °C
Ambient temperature range	+10/+43 °C
Software variant	M5+
K-Value	0.31 W/(m ² *K)
ATEX Marking	II 3G Ex nA nC nL IIB T3 Gc
ATEX certificate	-
Refrigerant	R290
Refrigerant charge	110 g
Refrigeration capacity at -10 °C	946 Watt
GWP - CO ₂ e	0.363
Energy consumption	2.56 kWh/24h
Heat emission 100 %	538 Watt
Heat emission default setpoint	106 Watt
Nominal consumption	586 Watt
Start current	13.2A
Sound level	47.5 dB(A)

BioPlus ER1400 G - with glass door

Technical specifications	Data
Temperature range	-2/+20 °C
Ambient temperature range	+10/+38° C
Software variant	M5+
K-Value	0.5808 W/(m ² *K)
ATEX Marking	II 3G Ex nA nC nL IIB T3 Gc
ATEX certificate	-
Refrigerant	R290
Refrigerant charge	110 g
Refrigeration capacity at -10 °C	946 Watt
GWP - CO ₂ e	0.363
Energy consumption	3.72 kWh/24h
Heat emission 100 %	539 Watt
Heat emission default setpoint	155 Watt
Nominal consumption	586 Watt
Start current	13.2A
Sound level	47.5 dB(A)

BioPlus RF1400 G
- with solid door

Technical specifications	Data
Temperature range	-25/-5 °C
Ambient temperature range	+10/+43 °C
Software variant	F51
K-Value	0.31 W/(m ² *K)
ATEX Marking	II 3G Ex nA nC nL IIB T3 Gc
ATEX certificate	-
Refrigerant	R290
Refrigerant charge	2 x 85 g
Refrigeration capacity at -25 °C	2 x 475 Watt
GWP - CO ₂ e	0.561
Energy consumption	8,56 kWh/24h
Heat emission 100 %	790 Watt
Heat emission default setpoint	349 Watt
Nominal consumption	860 Watt
Start current	13.2A
Sound level	46.6 dB(A)



BioPlus ER1400 G – with dual compressor and solid door

Technical specifications	Data
Temperature range	-2/+20 °C
Ambient temperature range	+10/+43 °C
Software variant	M5+
K-Value	0.31 W/(m ² *K)
ATEX Marking	II 3G Ex nA nC nL IIB T3 Gc
ATEX certificate	-
Refrigerant	R290
Refrigerant charge	2 x 120 g
Refrigeration capacity at -10 °C	2 x 719 Watt
GWP – CO ₂ e	0.792
Energy consumption	2.81 kWh/24h
Heat emission 100 %	761 Watt
Heat emission default setpoint	117 Watt
Nominal consumption	828 Watt
Start current	13.6A
Sound level	-

BioPlus ER1400 G – with dual compressor and glass door

Technical specifications	Data
Temperature range	-2/+20 °C
Ambient temperature range	+10/+38 °C
Software variant	M5+
K-Value	0.5808 W/(m ² *K)
ATEX Marking	II 3G Ex nA nC nL IIB T3 Gc
ATEX certificate	-
Refrigerant	R290
Refrigerant charge	2 x 120
Refrigeration capacity at -10 °C	2 x 719 Watt
GWP – CO ₂ e	0.792
Energy consumption	3.965 kWh/24h
Heat emission 100 %	767 Watt
Heat emission default setpoint	165 Watt
Nominal consumption	828 Watt
Start current	13.6A
Sound level	-



BioPlus RF1400 G – with dual compressor and solid door

Technical specifications	Data
Temperature range	-25/-5 °C
Ambient temperature range	+10/+43 °C
Software variant	F51
K-Value	0.31 W/(m ² *K)
ATEX Marking	II 3G Ex nA nC nL IIB T3 Gc
ATEX certificate	-
Refrigerant	R290
Refrigerant charge	2 x 85 g
Refrigeration capacity at -25 °C	2 x 633 Watt
GWP – CO ₂ e	0.561
Energy consumption	8.56 kWh/24h
Heat emission 100 %	790 Watt
Heat emission default setpoint	349 Watt
Nominal consumption	930 Watt
Start current	13.2A
Sound level	46.6 dB(A)

BioMidi



English EC Declaration of Conformity

We, **Gram Scientific ApS**, declare as manufacturers under sole responsibility that the following products comply with all relevant regulations:

Range:	BioMidi
Model:	RR425, RF425, RR625, RF625 & EF425
Refrigeration:	R290, R404A & R134a
Product description:	Refrigerators and freezer for laboratory and biostorage
Valid from (Year/Week):	2023/01

This declaration pertains to compliance with all applicable essential requirements and other provisions of the European Council Directive and regulations. Specifically, the following Directives and Regulations of the European Parliament and of the Council apply:

Directives and Regulations of the European Parliament and of the Council:
Machinery Directive 2006/42/EC
- ATEX Directive 2014/34/EU
- Pressure Equipment Directive 2014/68/EU
- Low Voltage Directive 2014/35/EU
- EMC Directive 2014/30/EU
- RoHS Directive 2011/65/EU
- REACH EC No. 1907/2006
- F-Gas Regulation (EU) No 2024/573

Product compliance has been demonstrated based on the following harmonized standards:

Harmonized Standards:	Text:
EN 61010-1:2010	Safety requirements for electrical equipment for measurement, control, and laboratory use – Part 1: General requirements
EN 60601-1:2006	Medical electrical equipment. General requirements for basic safety and essential performance
EN 60601-1-2:2015	Medical electrical equipment – Part 1-2: General requirements for basic safety and essential performance - Collateral standard: Electromagnetic compatibility - Requirements and tests
EN 60079-0:2012	Electrical apparatus for explosive atmospheres – Part 0: General requirements
EN 60079-11:2012	Explosive atmospheres – Part 11: Equipment protection by intrinsic safety "i"
EN 60079-15:2010	Explosive atmospheres – Part 15: Equipment protection by type of protection "n"
EN 60079-25:2010	Explosive atmospheres – Part 25: Intrinsically safe systems
EN ISO 3744:2010	Acoustics – Determination of sound power levels of noise sources using sound pressure - Engineering method in an essentially free field over a reflecting plane
EN ISO 9001:2015	Quality management systems
EN ISO 14001:2015	Environment management systems – Requirements with guidance for use

Gram Scientific ApS
 Aage Grams Vej 1
 DK-6500 Vojsens
 Denmark
 Telephone: + 45 73 20 13 00

Vojsens, 05.03.2024



John B. S. Petersen
 Approval Manager

BioMidi – Accessory code 69



English EC Declaration of Conformity

We, **Gram Scientific ApS**, declare as manufacturer under sole responsibility that the following products comply with all relevant regulations:

Range:	BioMidi (Accessory code 69)
Model:	RR425, RF425, RR625, RF625 & EF425
Refrigeration:	R290, R404A & R134a
Product description:	Refrigerators for laboratory and biostorage
Valid from (Year/Week):	2024/01

This declaration pertains to compliance with all applicable essential requirements and other provisions of the European Council Directive and regulations. Specifically, the following Directives and Regulations of the European Parliament and of the Council apply:

Directives and Regulations of the European Parliament and of the Council:

Machinery Directive 2006/42/EC
 - Pressure Equipment Directive 2014/68/EU
 - Low Voltage Directive 2014/35/EU
 - EMC Directive 2014/30/EU
 - RoHS Directive 2011/65/EU
 - REACH EC No.1907/2006
 - F-Gas Regulation (EU) No 2024/573

Product compliance has been demonstrated based on the following harmonized standards:

Harmonized Standards:	Text:
EN 61010-1:2010	Safety requirements for electrical equipment for measurement, control, and laboratory use – Part 1: General requirements
EN 60601-1:2006	Medical electrical equipment. General requirements for basic safety and essential performance
EN 60601-1-2:2015	Medical electrical equipment – Part 1-2: General requirements for basic safety and essential performance - Collateral standard: Electromagnetic compatibility - Requirements and tests
DIN 13277:2022-05	Refrigerators and freezers for laboratory and medical applications – Terminology, requirements, testing
EN ISO 3744:2010	Acoustics – Determination of sound power levels of noise sources using sound pressure - Engineering method in an essentially free field over a reflecting plane
EN ISO 9001:2015	Quality management systems
EN ISO 14001:2015	Environment management systems – Requirements with guidance for use

Gram Scientific ApS
 Aage Grams Vej 1
 DK-6500 Vojens
 Denmark
 Telephone: + 45 73 20 13 00

Vojens, 15.05.2024

John B. S. Petersen
 Approval Manager

Rev. 009 – 15.05.2024

BioPlus



English EC Declaration of Conformity

We, **Gram Scientific ApS**, declare as manufacturers under sole responsibility that the following products comply with all relevant regulations:

Range:	BioPlus
Model:	ER500, RF500, ER600D, RF600D, ER600W, RF600W, ER660D, RF660D, ER660W, RF660W, ER930, RF930, ER1270, RF1270, ER1400, RF1400, EF600W & EF660W
Refrigeration:	R290, R404A & R134a
Product description:	Refrigerators and freezer for laboratory and biostorage
Valid from (Year/Week):	2023/01

This declaration pertains to compliance with all applicable essential requirements and other provisions of the European Council Directive and regulations. Specifically, the following Directives and Regulations of the European Parliament and of the Council apply:

Directives and Regulations of the European Parliament and of the Council:
Machinery Directive 2006/42/EC
- ATEX Directive 2014/34/EU
- Pressure Equipment Directive 2014/68/EU
- Low Voltage Directive 2014/35/EU
- EMC Directive 2014/30/EU
- RoHS Directive 2011/65/EU
- REACH EC No.1907/2006
- F-Gas Regulation (EU) No 2024/573

Product compliance has been demonstrated based on the following harmonized standards:

Harmonized Standards:	Text:
EN 61010-1:2010	Safety requirements for electrical equipment for measurement, control, and laboratory use – Part 1: General requirements
EN 60601-1:2006	Medical electrical equipment. General requirements for basic safety and essential performance
EN 60601-1-2:2015	Medical electrical equipment – Part 1-2: General requirements for basic safety and essential performance - Collateral standard: Electromagnetic compatibility - Requirements and tests
EN 60079-0:2012	Electrical apparatus for explosive atmospheres – Part 0: General requirements
EN 60079-11:2012	Explosive atmospheres – Part 11: Equipment protection by intrinsic safety "i"
EN 60079-15:2010	Explosive atmospheres – Part 15: Equipment protection by type of protection "n"
EN 60079-25:2010	Explosive atmospheres – Part 25: Intrinsically safe systems
EN ISO 3744:2010	Acoustics – Determination of sound power levels of noise sources using sound pressure - Engineering method in an essentially free field over a reflecting plane
EN ISO 9001:2015	Quality management systems
EN ISO 14001:2015	Environment management systems – Requirements with guidance for use

Gram Scientific ApS
 Aage Grams Vej 1
 DK-6500 Vojens
 Denmark
 Telephone: + 45 73 20 13 00

Vojens, 05.03.2024



John B. S. Petersen
 Approval Manager

BioPlus – Accessory code 69



English EC Declaration of Conformity

We, **Gram Scientific ApS**, declare as manufacturer under sole responsibility that the following products comply with all relevant regulations:

Range:	BioPlus (Accessory code 69)
Model:	ER500, RF500, ER600D, RF600D, ER600W, RF600W, ER660D, RF660D, ER660W, RF660W, ER930, RF930, ER1270, RF1270, ER1400, RF1400, EF600W & EF660W
Refrigeration:	R290, R404A & R134a
Product description:	Refrigerators for laboratory and biostorage
Valid from (Year/Week):	2024/01

This declaration pertains to compliance with all applicable essential requirements and other provisions of the European Council Directive and regulations. Specifically, the following Directives and Regulations of the European Parliament and of the Council apply:

Directives and Regulations of the European Parliament and of the Council:

Machinery Directive 2006/42/EC
- Pressure Equipment Directive 2014/68/EU
- Low Voltage Directive 2014/35/EU
- EMC Directive 2014/30/EU
- RoHS Directive 2011/65/EU
- REACH EC No.1907/2006
- F-Gas Regulation (EU) No 2024/573

Product compliance has been demonstrated based on the following harmonized standards:

Harmonized Standards:	Text:
EN 61010-1:2010	Safety requirements for electrical equipment for measurement, control, and laboratory use – Part 1: General requirements
EN 60601-1:2006	Medical electrical equipment. General requirements for basic safety and essential performance
EN 60601-1-2:2015	Medical electrical equipment – Part 1-2: General requirements for basic safety and essential performance - Collateral standard: Electromagnetic compatibility - Requirements and tests
DIN 13277:2022-05	Refrigerators and freezers for laboratory and medical applications – Terminology, requirements, testing
EN ISO 3744:2010	Acoustics – Determination of sound power levels of noise sources using sound pressure - Engineering method in an essentially free field over a reflecting plane
EN ISO 9001:2015	Quality management systems
EN ISO 14001:2015	Environment management systems – Requirements with guidance for use

Gram Scientific ApS
Aage Grams Vej 1
DK-6500 Vojens
Denmark
Telephone: + 45 73 20 13 00

Vojens, 15.05.2024

John B. S. Petersen
Approval Manager

Rev. 009 – 15.05.2024

BioMidi/BioPlus

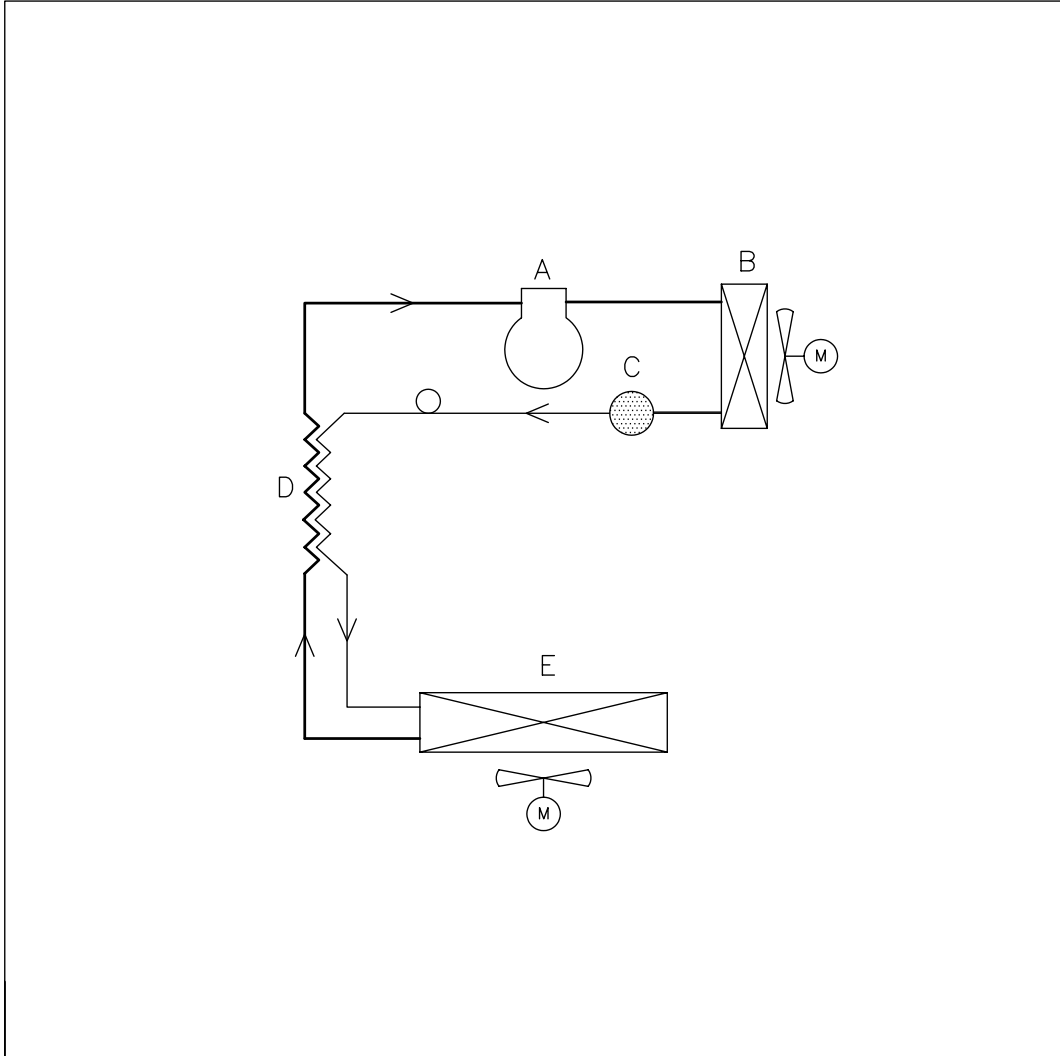

	DK	GB	D
A	Kompressor	Compressor	Kompressor
B	Kondensator	Condenser	Verflüssiger
C	Tørrefilter	Filter drier	Trockenfilter
D	Varmeudveksler	Heat exchanger	Wärmeaustauscher
E	Fordamper	Evaporator	Verdampfer

Description: Rørdiagram/Piping diagram/Rohrleitungsplan HAV		General tolerances: ISO 2768-1 (m) ISO 2768-2 (L)		
 © Gram Scientific ApS DENMARK	Date: 141201	Drawing no.:	Sheet no.:	Rev.
	Name: JP	765040844	1 of 1	00
	Scale 1/1			

All rights to this drawing belongs to Gram Scientific ApS, cf. law of Copyright. Thus the drawing should not without our written permission be copied, presented or passed over to a third person. Misuse will lead to prosecution.

BioPlus – With dual refrigeration

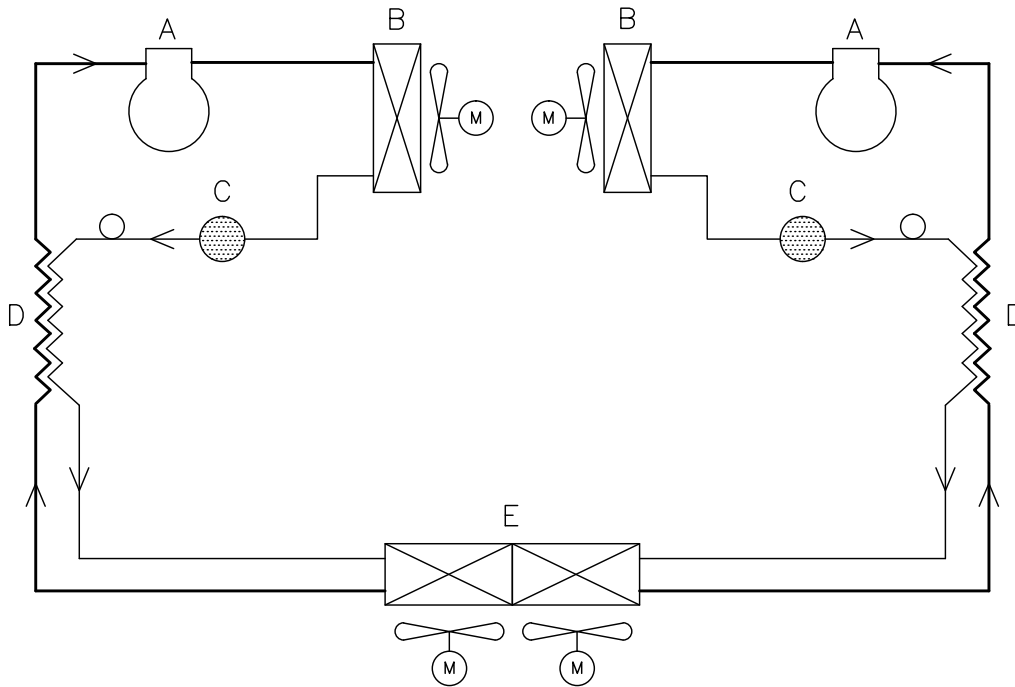

	DK	GB	D
A	Kompressor	Compressor	Kompressor
B	Kondensator	Condenser	Verflüssiger
C	Tørrefilter	Filter drier	Trockenfilter
D	Varmeudveksler	Heat exchanger	Wärmeaustauscher
E	Fordamper	Evaporator	Verdampfer

Revision:

Description: Piping diagram BioPlus w/dual refrigeration		General tolerances: ISO 2768-1 (m) ISO 2768-2 (L)			
 © Gram Scientific ApS DENMARK	Date: 09-07-2010	Drawing no.:	Sheet no.:	Rev.	A format
	Name: JABP	765041375	1 of 1	000	4
	Scale: 1/1				

All rights to this drawing belongs to Gram Scientific ApS, cf. law of Copyright. Thus the drawing should not without our written permission be copied, presented or passed over to a third person. Misuse will lead to prosecution.

BioPlus RF - With SSR

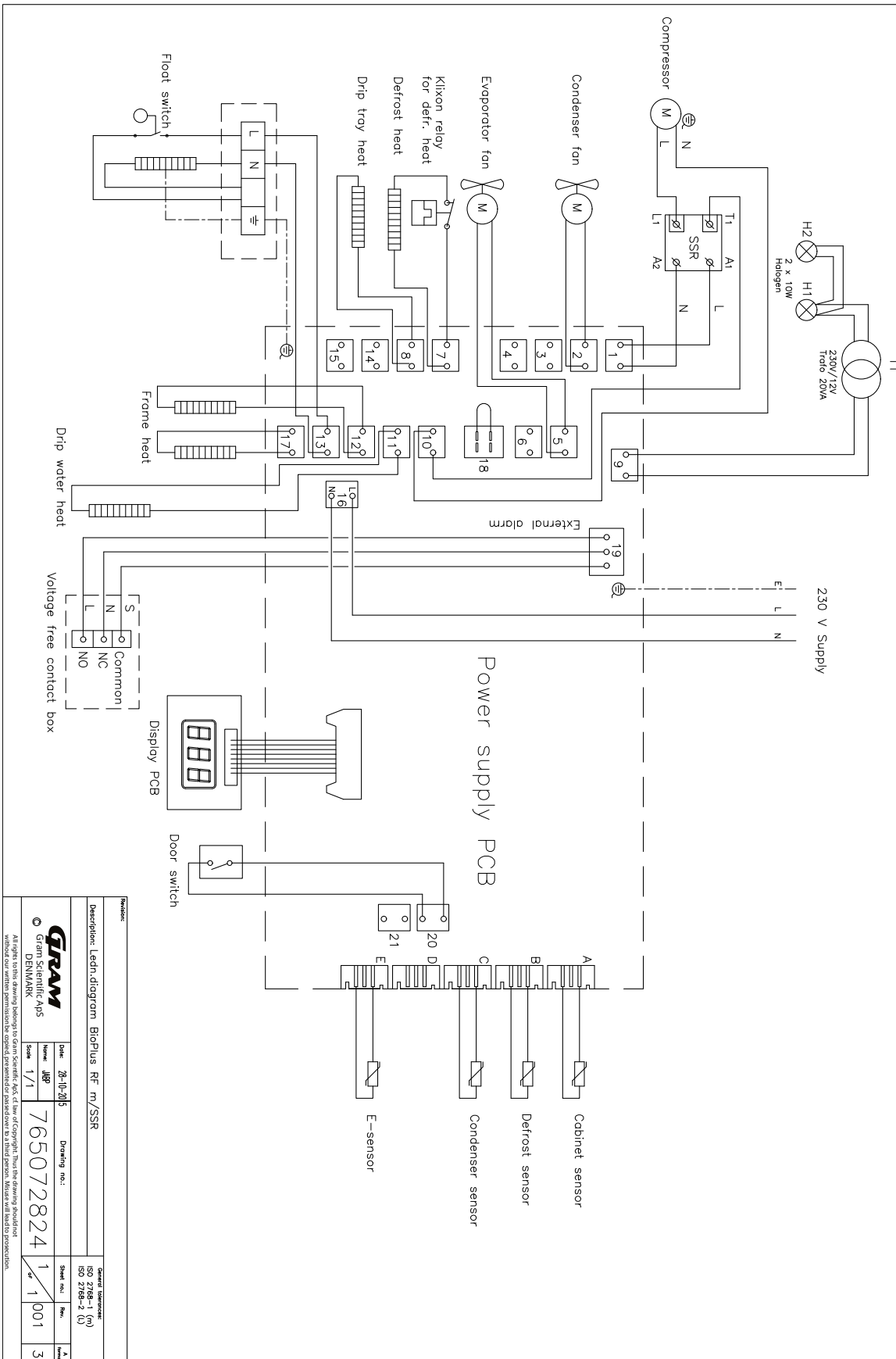

Revision		Drawing no.:		Serial no.:		Rev.:		A	
Description: Ledn. diagram BioPlus RF m/SSR		Date: 26-10-2015		765072824		1		1	
© Gram Scientific A/S DENMARK		Name: JBP		Scale: 1/1		1		001	
All rights in this drawing belong to Gram Scientific A/S. All use of copyright. That the drawing is made without our written permission is copied, presented or passed down by third person. Material will lead to prosecution.		ISO 2768-1 (M) ISO 2768-2 (L)							

BioPlus ER – With SSR

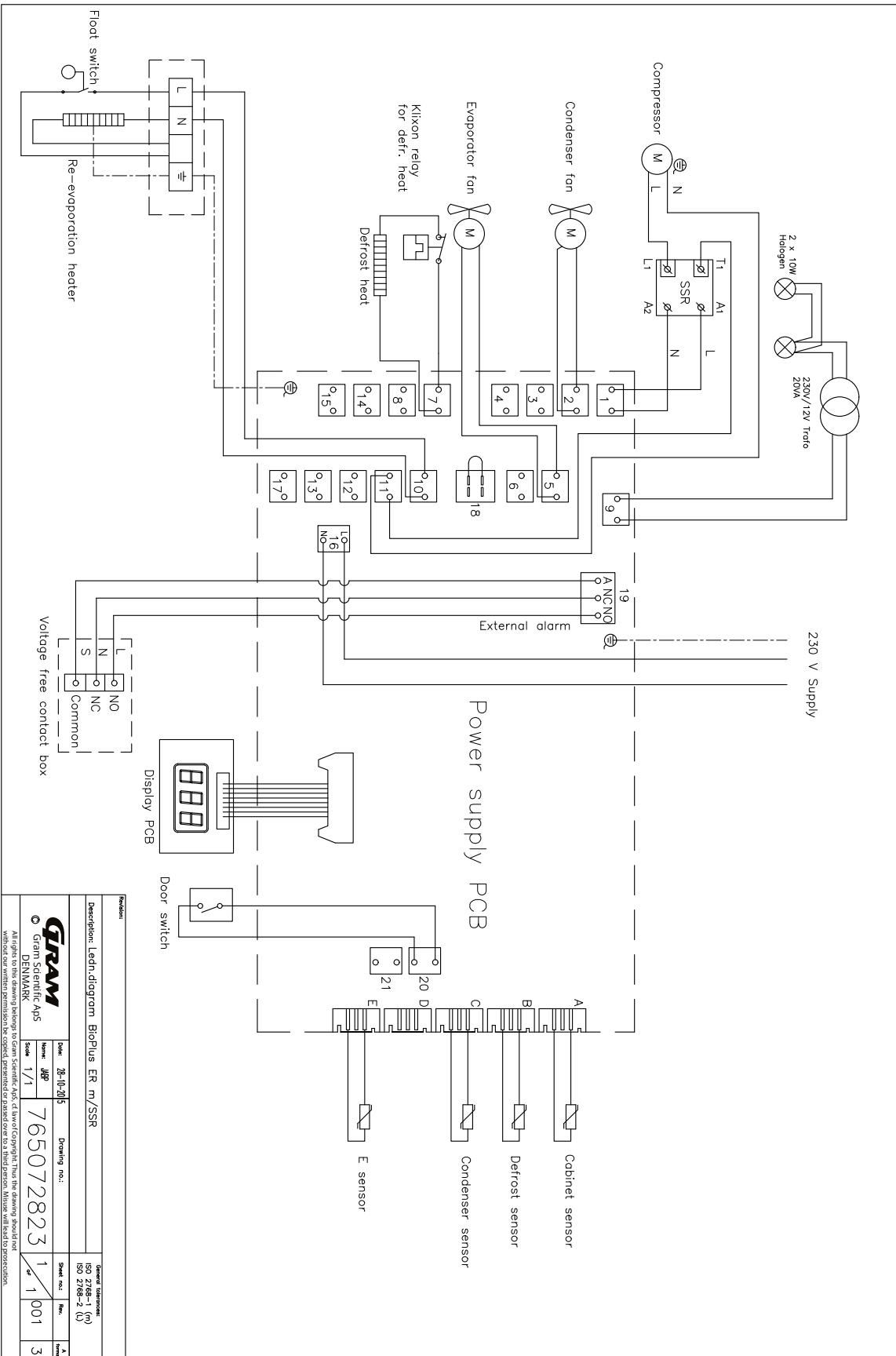

Revision:		765072823	
Description: Ledn.diagram BioPlus ER m/SSR		Drawing no.:	
© Gram Scientific ApS		Scale: 1/1	
DANMARK		Sheet no.:	
All rights of this drawing belongs to Gram Scientific ApS. All other Copyright. This drawing should not be copied, reproduced or passed over to a third person. Misuse will lead to prosecution.		Rev.:	
765072823		1	
1		1	
3		3	

BioPlus EF600/660 – With SSR

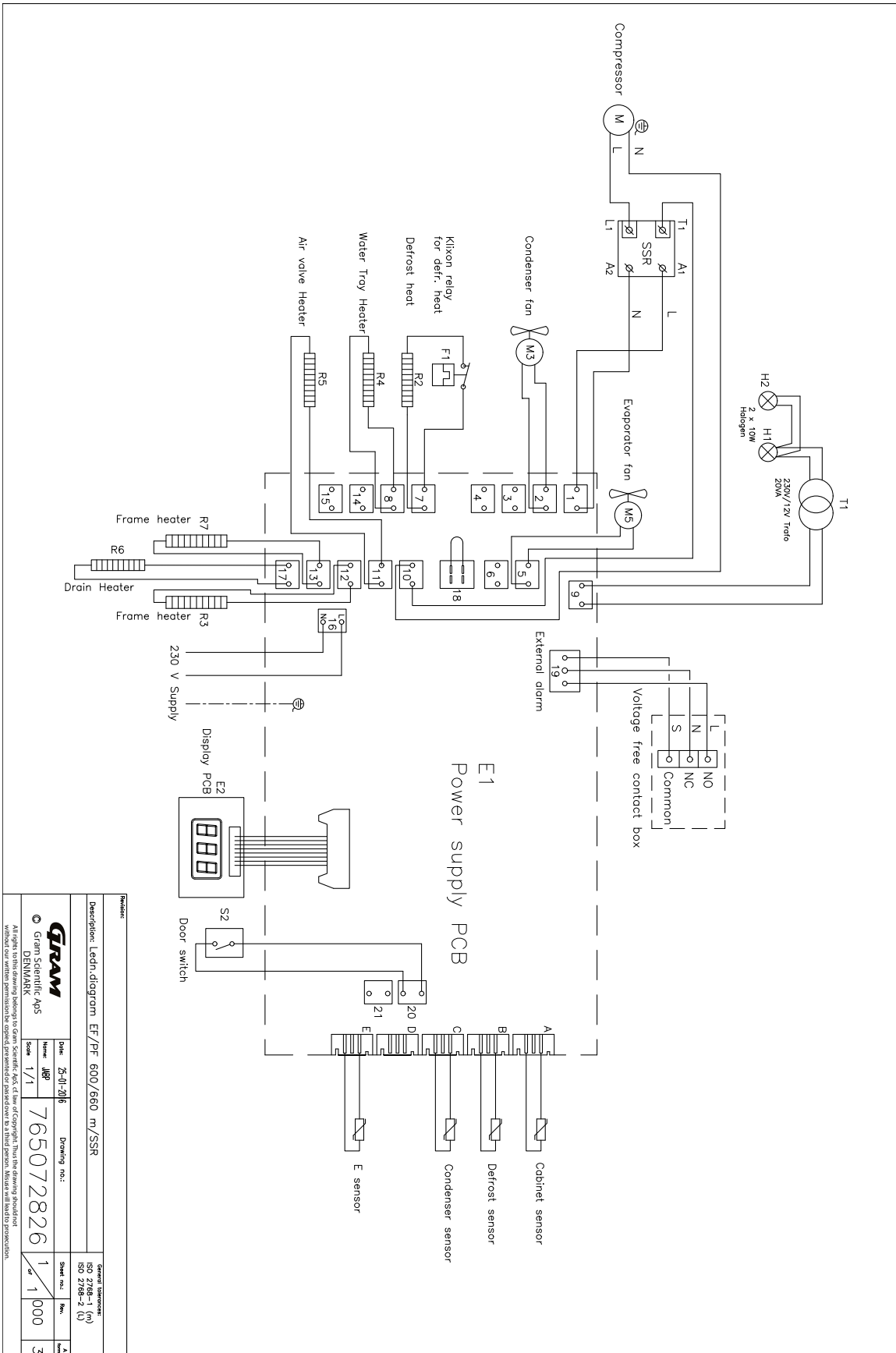

Revision:

Description: Ledn. diagram EF/PF 600/660 m/SSR

Geometrische Normen:
ISO 2768-1 (M)
ISO 2768-2 (C)

GRAM
Gramm Scientific APS
DIN/ANSI

Rev: 25-01-2016
Name: JRP
Scale: 1/1
Drawing no.: 765072826

Sheet no.: 1
Rev: 1
A

All rights reserved. Inquiries to Gram Scientific APS, all other rights reserved. This drawing is the property of Gram Scientific APS and may be used only for the production of the product for which it was created. Any other use without our written permission is strictly prohibited. Gram Scientific APS shall not be held liable for any damage or loss of data.

BioPlus ER1270/1400 - With SSR

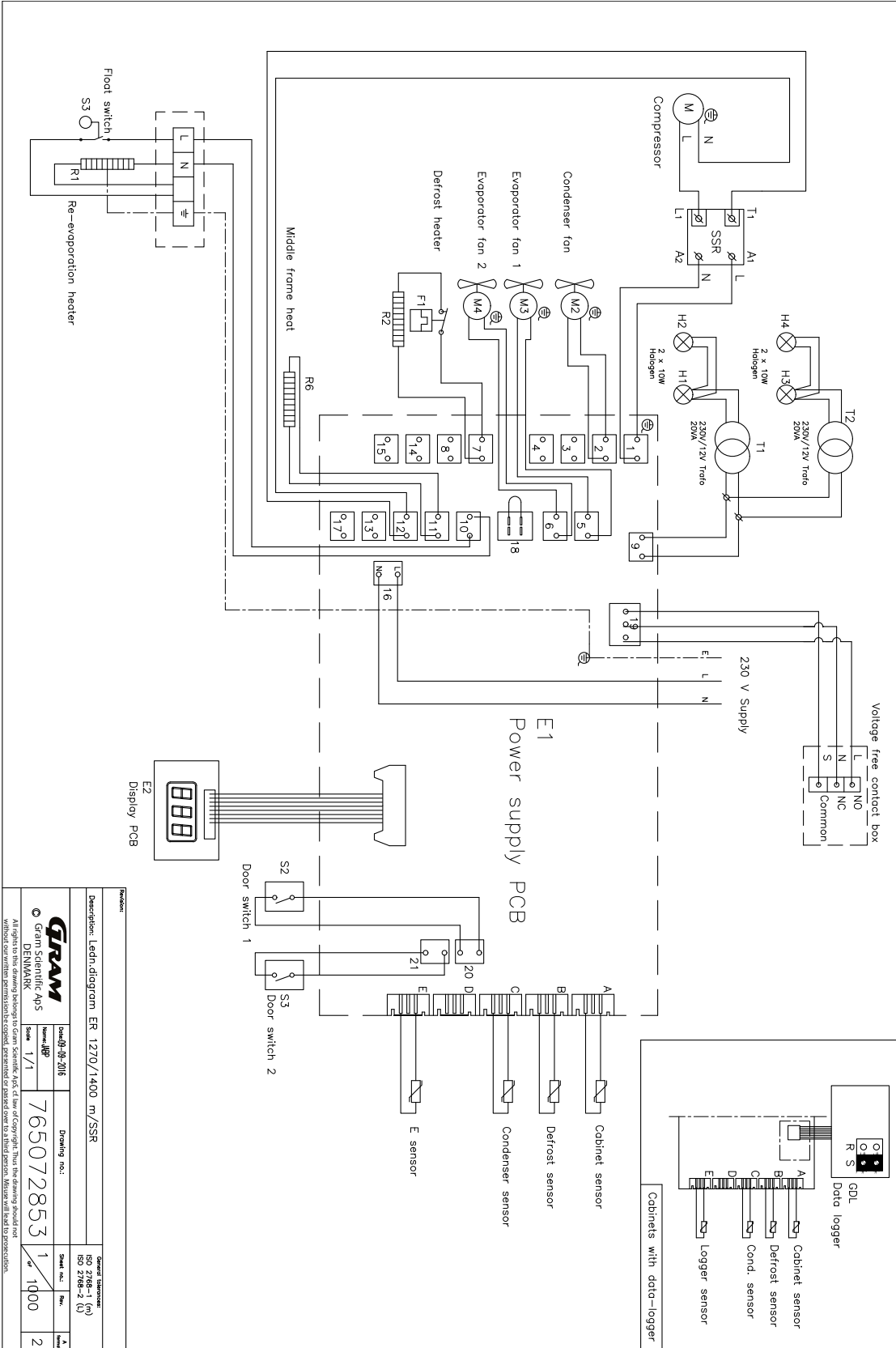

Revision		Drawing no.:		Scale		Sheet no.:		Total sheets:	
Description: Ledn-diagram ER 1270/1400 m/SSR		765072853		1/1		1		2	
Gramsnummer: ISO 2768-1 (M) ISO 2768-2 (L)		765072853		1/1		1		2	
Description: Ledn-diagram ER 1270/1400 m/SSR		765072853		1/1		1		2	
Gramsnummer: ISO 2768-1 (M) ISO 2768-2 (L)		765072853		1/1		1		2	

© Gram Scientific Aps
DENMARK
Scale 1/1
Drawing no.: 765072853
Sheet no.: 1
Total sheets: 2

All rights to this drawing belong to Gram Scientific Aps. If law of copyright, thus the drawing should not be copied, reproduced or passed over to a third person. Anyone who does so will lead to prosecution.

BioPlus RF1270/1400 - With dual compressor - With SSR

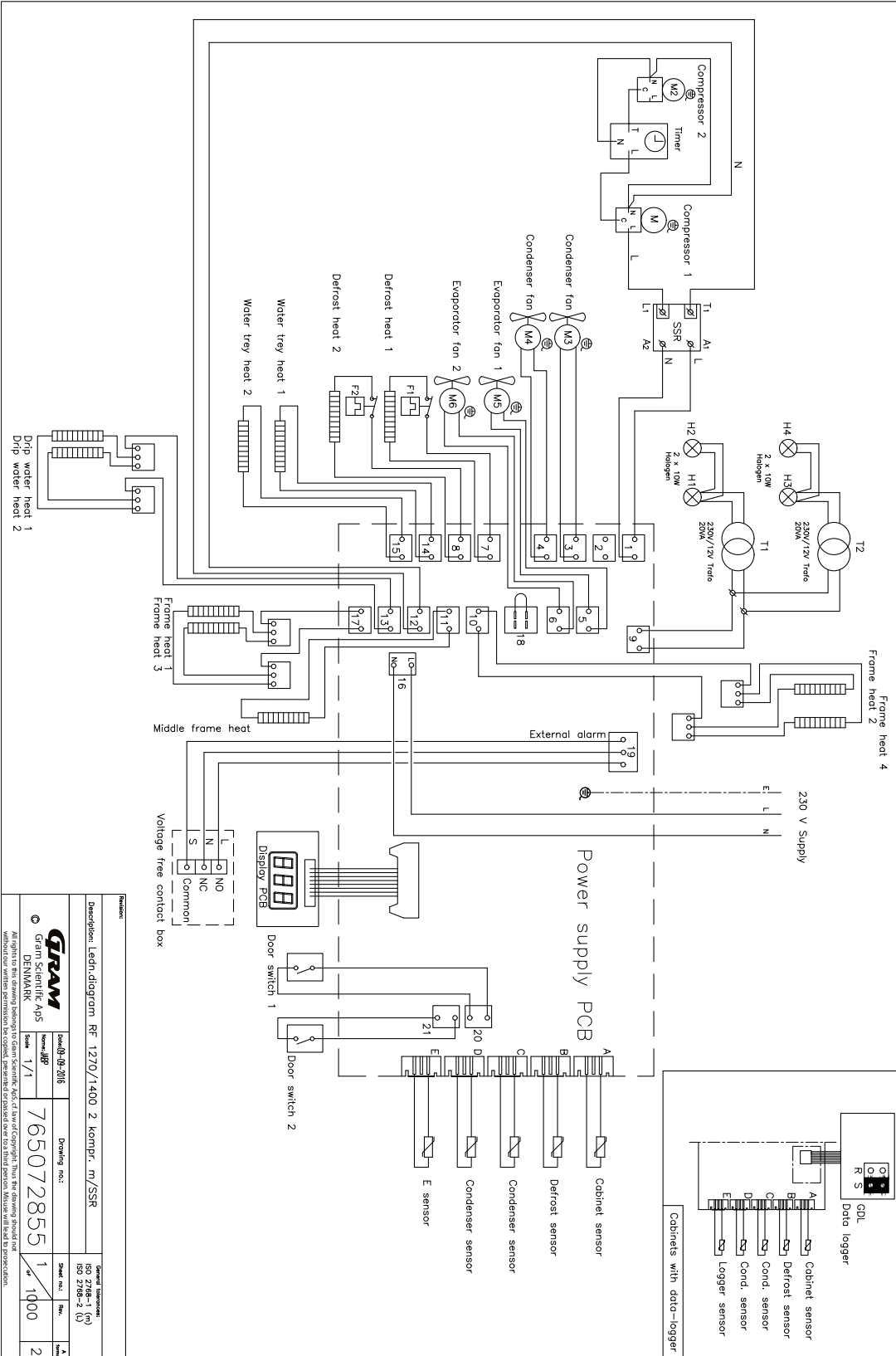

BioPlus ER1270/1400 - With dual compressor - With SSR

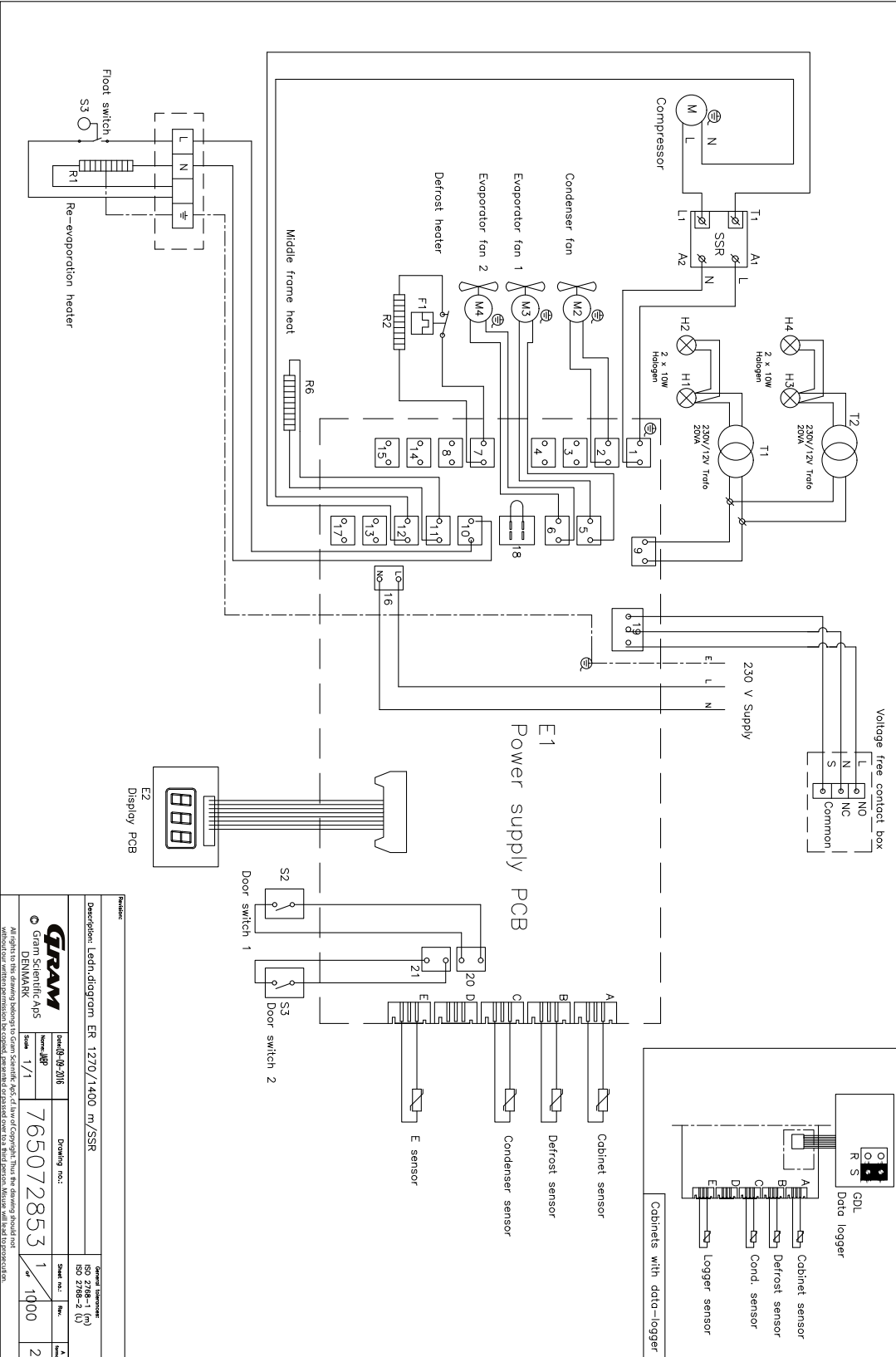

Description: LetIn.dlogram ER 1270/1400 m/SSR		Drawing no:	
Date: 09-09-2016		Scale: 1/1	
765072853		1	
100 2706-1 (A)		1000	
100 2706-1 (A)		2	

BioPlus RF/EF - With dual compressor - With SSR

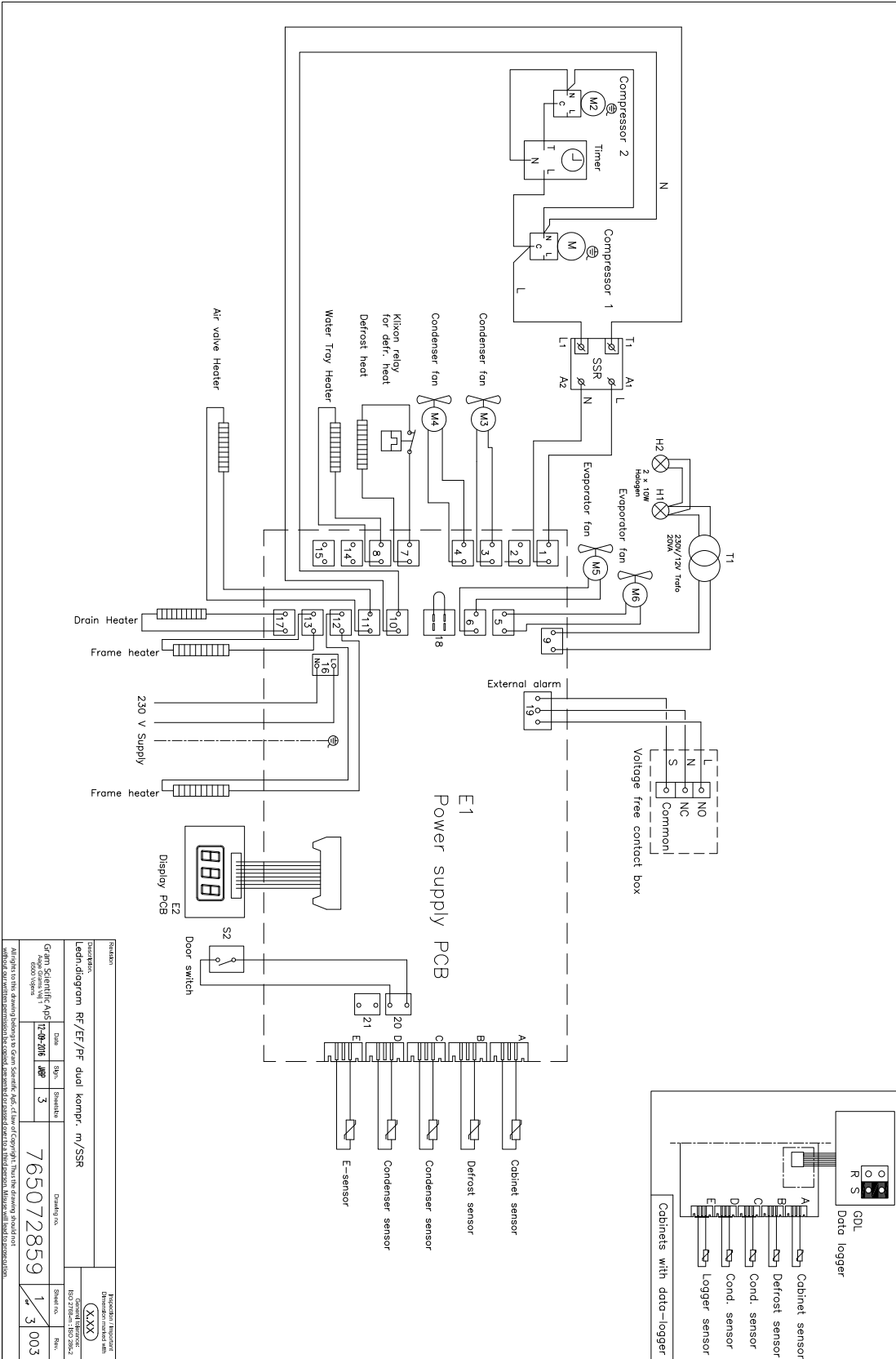

Description:		Klixa	
Leden/diagram RF/EF/RF dual kompr. in/SSR		Klixa	
Grunt Scientific ApS	Dato:	Stipo:	Shedule:
12-08-2016	18-08-2016	3	
765072859	1	3	003

BioMidi RF425/625 - With SSR

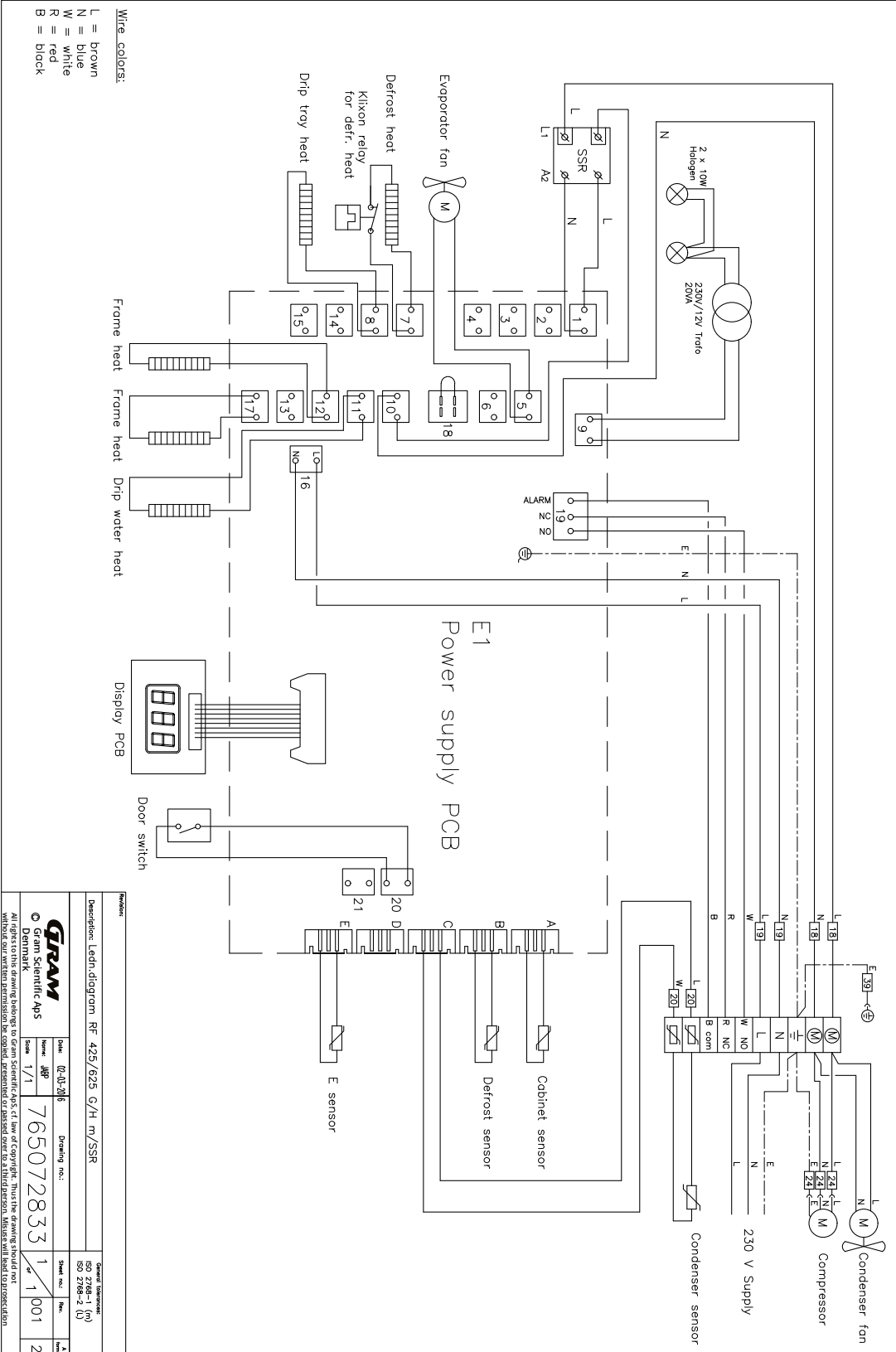

Revision

Description: Ledlin diagram RF 425/625 G/H m/SSR

General Information

Date: 02-01-2016

SSO 2786-1 (A)

Author: JBP

SSO 2786-2 (U)

Scale: 1/1

Sheet no.: 1

Drawing no.: 765072833

Rev.: 1

© Gram Scientific Aps

Page: 2

Denmark

1/1

All rights reserved. No part of this publication may be reproduced, stored in a retrieval system, or transmitted, in any form or by any means, without the written permission of the copyright holder.

1/1

Gram Scientific Aps

1/1

Denmark

1/1

All rights reserved. No part of this publication may be reproduced, stored in a retrieval system, or transmitted, in any form or by any means, without the written permission of the copyright holder.

1/1

Gram Scientific Aps

1/1

Denmark

1/1

All rights reserved. No part of this publication may be reproduced, stored in a retrieval system, or transmitted, in any form or by any means, without the written permission of the copyright holder.

1/1

Gram Scientific Aps

1/1

BioMidi EF425 - With SSR

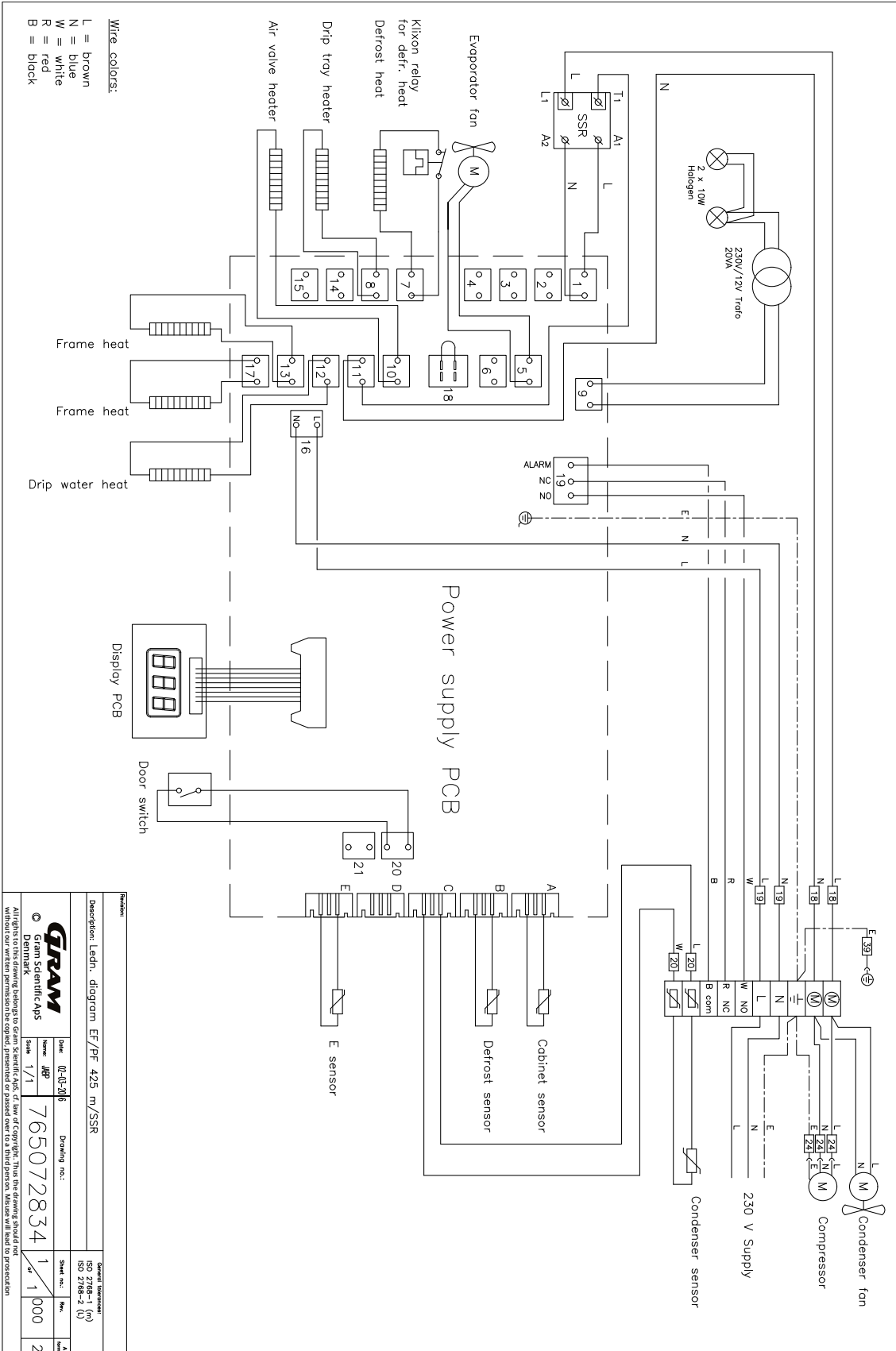

Description: Ledn. diagram EF/PF 425 m/SSR		Drawing no.:	
Date: 02-05-2016		Scale: 1/1	
Author: JPP		Sheet no.: 1	
765072834		Rev.: 1	
Scale: 1/1		Total sheets: 2	

© Gram Scientific APS
 All rights to the drawing belong to Gram Scientific A/S. In case of copyright, this drawing should not be reproduced or used in any way without our written permission. The copyright is reserved for Gram Scientific A/S. Misuse will lead to prosecution.

General maintenance information

- Implement a cleaning routine.
- Cleaning tasks should be documented and kept record of.
- Check the temperature of your refrigerator/freezer regularly.
- When storing valuable or temperature-sensitive materials or products, it is advisable to employ a continuously monitoring autonomous alarm system. This alarm system should be designed in a manner that allows authorised individuals to promptly detect each alarm state and take the necessary corrective actions.

- WARNING -

Maintenance work should only be performed by a Gram BioLine authorised technician.



Make sure that the refrigerator/freezer is switched off at the socket before any maintenance work is performed. Transfer all contents to another refrigerator or freezer under safe and regulated conditions.

Maintenance plan

Component	Task	Frequency
Base	<ul style="list-style-type: none"> Ensure cabinets with legs are levelled properly and cabinets with castors are placed on a level surface and locked. 	Yearly
Interior fittings	<ul style="list-style-type: none"> Ensure that all interior fittings are fixed correctly. 	Yearly
Door gasket	<ul style="list-style-type: none"> Ensure that the gasket is pliable and in good working order. Ensure that the door is aligned with the door frame and fits tightly when closed. 	Yearly
Condenser and fan	<ul style="list-style-type: none"> Ensure it is not dented or shows any other signs of damage and does not make any abnormal noises. 	Yearly
Keypad	<ul style="list-style-type: none"> Ensure it is not dented or shows any other signs of damage. 	Yearly
Ice build-up	<ul style="list-style-type: none"> Ensure ice accumulation does not hinder operation or performance. 	Monthly
Power cord	<ul style="list-style-type: none"> Ensure correct fitment. 	Yearly
Compressor compartment	<ul style="list-style-type: none"> Ensure that the compressor compartment is kept free of dust or other contaminants. 	Yearly
Re-evaporation tray	<ul style="list-style-type: none"> Ensure it is not cracked or shows any other signs of damage. 	Yearly
Access port	<ul style="list-style-type: none"> Ensure that the access port is sealed properly and check for moisture ingress. 	Yearly
Defrost water tube (if applicable)	<ul style="list-style-type: none"> Inspect for damage and obstructions. 	Yearly
Door switch (if applicable)	<ul style="list-style-type: none"> Ensure proper functionality to guarantee the fan in the cabinet stops, the interior lighting turns on if present, and the display shows "-0-". 	Yearly
Door alarm test	<ul style="list-style-type: none"> Ensure it activates when the door is left open. 	Yearly
Temperature	<ul style="list-style-type: none"> Ensure the appliance consistently maintains correct storage conditions. When storing valuable or temperature sensitive materials or products, it is advisable to employ a continuously monitoring autonomous alarm system. This alarm system should be designed in a manner that allows authorised individuals to promptly detect each alarm state and take the necessary corrective actions. 	Yearly

Component	Task	Frequency
High and low temperature alarms	<ul style="list-style-type: none"> • Ensure that the temperature alarms are set and work accordingly. • When storing valuable or temperature sensitive materials or products, it is advisable to employ a continuously monitoring autonomous alarm system. This alarm system should be designed in a manner that allows authorised individuals to promptly detect each alarm state and take the necessary corrective actions. 	Yearly
Door hinges	<ul style="list-style-type: none"> • Check for wear and ensure proper function. 	Yearly
Door self-closing mechanism	<ul style="list-style-type: none"> • Ensure that the door automatically closes when opened < 90 °. • Ensure that the door stays/do not close when opened > 90 °. 	Yearly
Door handle (if applicable)	<ul style="list-style-type: none"> • Ensure secure attachment and correct engagement. 	Yearly
Chart recorder (if applicable)	<ul style="list-style-type: none"> • Ensure that it accurately records and stores temperature data. 	Yearly
Lock	<ul style="list-style-type: none"> • Ensure it operates smoothly. 	Yearly
Sensors	<ul style="list-style-type: none"> • Test sensors to ensure accurate readings and functionality. 	Yearly
Cleaning	<ul style="list-style-type: none"> • Refer to the cleaning section. 	

- SPARE PARTS -



If you require spare parts, please contact your local Gram BioLine distributor. Defective parts must be replaced with original parts from Gram BioLine. Gram BioLine can only guarantee functional and safety requirements on the cabinets, if above mentioned is adhered to.

- The refrigerator/freezer must be cleaned before taken into operation.
- We recommend cleaning the refrigerator/freezer regularly to ensure efficient operation.
- We recommend using pH-neutral all-purpose cleaners and soft cleaning cloths.
- If any detergent or cleaning agent are used to clean the refrigerator/freezer, ensure that the refrigerator/freezer is thoroughly rinsed with clean water and a clean cloth to remove any cleaning agent or detergent traces.
- Ensure that the refrigerator/freezer has been dried thoroughly with a clean cloth before taken into operation.

- WARNING -

Do not use the below disinfectants and cleaners:



- Do not use abrasive cleaners.
- Do not use harsh chemicals.
- Do not use solvents.
- Do not use acidic or alkaline cleaners nor any cleaning agents that contain chloride.

- WARNING -

Do not use the below tools in general:



- Do not use metal brushes.
- Do not use water jets.
- Do not use abrasive sponges or steel wool.
- Do not use any sharp tools.
- Do not use electrical heating or steam-cleaning appliances, flames, or defroster sprays to defrost.

- WARNING -

- Do not remove the type/number plate, located inside the refrigerator/freezer (refer to type/number plate section).
- Make sure no water gets close to any electrical components.
- Do not flush the compressor compartment and evaporator with water as this may cause short-circuits in the electrical system.

Cleaning plan

The following cleaning plan represents a generic schedule for cleaning.
Use and/or conditions may impact the required frequency of the subsequent points.

Task	Minimum maintenance interval
Cleaning the air filters (if applicable)	Yearly
Cleaning the re-evaporation tray	Yearly
Cleaning the exterior	Half-yearly
Cleaning the interior	Half-yearly
Cleaning the shelves/drawers	Regularly
Cleaning the condenser and the compressor compartment	Yearly
Cleaning the door gasket	Regularly
Cleaning the defrost water tube (if applicable)	Yearly

Cleaning the air filters (if applicable)



- WARNING -

- The air filters should only be re-attached when completely dry.

Cleaning agents and tools

- pH-neutral all-purpose cleaners (optional).
- Soft cloth (optional).
- Bucket or similar (optional).

The air filters on the condenser and the front panel should be removed and cleaned with lukewarm water (max. 50° C). If the air filters are very dirty fill a bucket or similar with a mild solution of pH-neutral all-purpose cleaner. Submerge the air filters completely for approximately 10 minutes and rinse thoroughly with clean warm water. Let the air filter air-dry completely before reattaching them.

Cleaning the re-evaporation tray



- WARNING -

- Be careful not to damage the defrost water tube and the heating element (located in the tray) when cleaning.

Cleaning agents and tools

- Soft cloth.
- pH-neutral all-purpose cleaner.

It is recommended that the re-evaporation tray is checked regularly for foreign objects and cleaned with a pH-neutral all-purpose cleaner at least once a year. Rinse the tray thoroughly with clean warm water and remember to dry the re-evaporation tray completely.

Cleaning the interior and exterior



- WARNING -

- Do not use any tools or methods to speed up defrosting other than the ones specified in this instructions for use.
- Do not pour water directly into the unit.

Cleaning agents and tools

- pH-neutral all-purpose cleaners.
- Use a soft cloth to clean off dust or other contaminants from the refrigerator or freezer.

Manual defrost

Our conventional refrigerators/freezers feature automatic defrosts (see section for defrost) but the refrigerator/freezer should be manually defrosted prior to cleaning. Make sure all contents are stored elsewhere before defrosting.

Manual defrosting is done by switching off the refrigerator/freezer at the socket. Leave the door open for 24 hours and be cautious of excess water being spilled onto the floor. Be sure to keep the floor and the interior as dry as possible during the process by placing towels or similar onto the surfaces.

Remove all shelves and drawers and clean the cabinet (max. 85° C). Rinse the refrigerator/freezer thoroughly with clean warm water. Check and dry thoroughly before it is put into operation again.

Cleaning the shelves/drawers



- WARNING -

- Shelves/drawers shall be hand washed.
- Do not use excessive force when removing and inserting the shelves/drawers.

Cleaning agents and tools

- pH-neutral all-purpose cleaners.
- Soft cloth.

Remove all shelves/drawers from the refrigerator/freezer and wash them using a soft cloth. Rinse the shelves/drawers thoroughly with clean warm water. Check and dry thoroughly before it is put into operation again.

Cleaning the condenser and the compressor compartment



- WARNING -

- Ensure not to damage the condenser.
- Components in the compressor compartment may be hot.
- The refrigeration system and the hermetically sealed compressor require no maintenance.

Tools

- Use a brush, a soft cloth, or a vacuum cleaner.

The compressor compartment and in particular the condenser must be kept free from dust or other contaminants.

Cleaning the door gasket



- WARNING -

- Do not pour water directly into the unit.

Cleaning agents and tools

- pH-neutral all-purpose cleaners.
- Use a brush, a soft cloth, or a vacuum cleaner.

The door gasket should be cleaned regularly using a soft cloth. Dry the gasket completely with a clean cloth before taking the refrigerator/freezer into operation.

Cleaning the defrost water tube (if applicable)



- WARNING -

- Do not pour water directly into the unit.

Cleaning agents and tools

- pH-neutral all-purpose cleaners.
- Use a brush, a soft cloth, or a vacuum cleaner.

Remove the elastic water trap, located on the back of the cabinet, as illustrated. Inspect the defrost water tube for obstructions. Rinse and clean it and reinstall.

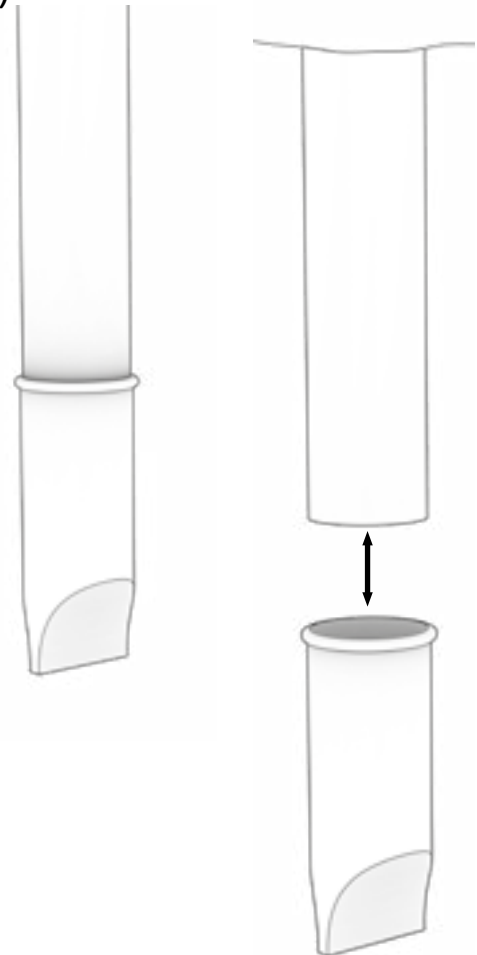

FAQ

Complication	Cause	Approach
Temperature fluctuations	Frequent door openings	<ul style="list-style-type: none"> • Make the door openings as brief as possible.
	Malfunctioning temperature sensor	<ul style="list-style-type: none"> • Use an independent temperature measurement device to measure the temperature inside the refrigerator/freezer to evaluate if it differs from the readings of the sensors in the appliance. • In case of significant temperature difference – contact Gram BioLine technical support.
	Dirty condenser	<ul style="list-style-type: none"> • Clean the condenser.
	Item distribution	<ul style="list-style-type: none"> • Ensure that the contents are evenly distributed and do not obstruct air circulation.
	Ambient conditions	<ul style="list-style-type: none"> • Ensure that the ambient temperature does not exceed the specified limits in this instructions for use. • Ensure the cabinet is not in direct contact with sunlight or effected by other heat sources. • The user must ensure that the cabinet is used in accordance with its intended use and that the humidity does not exceed 70%. • Ensure adequate ventilation around the refrigerator/freezer. (Refer to surroundings section)
	Item temperature	<ul style="list-style-type: none"> • Ensure that all contents are at set temperature before they are placed inside the refrigerator/freezer.
The refrigerator/freezer is not working	Power supply	<ul style="list-style-type: none"> • Ensure that the power cord is securely plugged into the socket and the refrigerator/freezer.
	Power outage	<ul style="list-style-type: none"> • Keep the door closed. • Use a backup power source if available. • Move contents to a working unit if available.
	Faulty outlet	<ul style="list-style-type: none"> • Check for blown fuses. • Check the circuit breaker and RCD (Residual Current Device).

- INFORMATION -

 If any issues persist, do not hesitate to reach out to Gram BioLine for professional support, at support@gram-bioline.com.

Complication	Cause	Approach
Noisy	Unlevel refrigerator/freezer	<ul style="list-style-type: none"> • Ensure that the floor is level. • Ensure that the base of the refrigerator/freezer is level. (Refer to installation section).
	Direct contact with other objects	<ul style="list-style-type: none"> • Ensure that the refrigerator/freezer is not in contact with the wall. • Ensure that the refrigerator/freezer is not in contact with another appliance or other objects.
	Fans (if applicable)	<ul style="list-style-type: none"> • Ensure the fans are operational and does not make any abnormal sounds.
Refrigerator/freezer unable to reach set temperature	Discrepancy between E-sensor and set temperature	<ul style="list-style-type: none"> • The display may show a different temperature because the E-sensor is located at the warmest spot in the unit. <p>However, the temperature in the central area where contents are stored should be at the set temperature.</p> <p>Verify this with an independent temperature measurement. If you have concerns, please contact our customer support team.</p>
	Damaged door gasket	<ul style="list-style-type: none"> • Ensure that the gasket is pliable and in good working order.
Need for spare parts	Replacement parts are required	<ul style="list-style-type: none"> • If you require spare parts, please contact your local Gram BioLine distributor.



- INFORMATION -

If any issues persist, do not hesitate to reach out to Gram BioLine for professional support, at support@gram-bioline.com.

IQ & OQ

Installation Qualification Operation Qualification

The following IQ/OQ is intended to be a guideline, local IQ/OQ procedures can vary depending on application and items stored in the Gram BioLine cabinet.

Deviations from the specifications dictated in the PQ are to be reported in the deviation report.

The IQ/OQ is concluded if all criteria of acceptance are approved and the possible deviations are rectified or accepted.

Organisation:

Location of installation:

Model:

Serial number:

Item and revision number of instructions for use:

Status of operation:

- Active
- Inactive

Name of vendor:

Warranty:

Start: _____

End: _____

Model: _____

SN: _____

Instructions on use to starting the cabinet:

- 1. Training of the responsible party Date: _____ By: _____
- 2. Operational test of the cabinet Date: _____ By: _____
- 3. Responsible party _____ Tel: _____

Instructions to users:

The responsible party is trained in use of the cabinet in reference to the user manual

- General use of cabinet
- Service & maintenance
- The cabinet was delivered without defects/damage.
The cabinet started as specified in the user manual

Objections to the mentioned:

Set values:

Setpoint temperature _____ °C

Local alarm settings:

- Upper temperature alarm limit (LhL) _____ °C
- Lower temperature alarm limit (LLL) _____ °C

External alarm settings:

(See voltage-free contact in user manual)

- Upper temperature alarm limit (EhL) _____ °C
- Lower temperature alarm limit (ELL) _____ °C

Factory settings					
Model/ Setpoint temperature		LhL	LLL	EhL	ELL
RR - BioMidi	+5 °C	+25 °C	0 °C	+25 °C	0 °C
ER - BioPlus	+5 °C	+25 °C	-5 °C	+25 °C	-5 °C
RF - BioPlus/BioMidi	-20 °C	+25 °C	-35 °C	+25 °C	-35 °C
EF - BioPlus	-35 °C	+25 °C	-45 °C	+25 °C	-45 °C
EF - BioMidi	-40 °C	+25 °C	-60 °C	+25 °C	-60 °C

Date: _____ Name of trained user: _____ Signature: _____ Name of instructor: _____ Signature: _____

Model: _____ SN: _____

Installation Qualification - IQ

ID	Description of installation	Reference in manual	Comply		Attachment	Notes
			Yes	No		
I-0	The cabinet is shipped with a transport bracket that should be removed prior to use.	N/A				
I-1	Ensure the cabinet is installed indoors.	Page 10				
I-2	Ensure the cabinet is installed in a dry and sufficiently ventilated area.	Page 10				
I-3	Ensure the cabinet is not in direct contact with sunlight or other heat sources.	Page 10				
I-4	Ensure that the ambient operating temperature is within the allowed range.	Page 10				
I-5	Ensure that the cabinet is not installed in a chloric/acidic environment.	Page 10				
I-6	Ensure that the protective film on the cabinet is removed.	Page 10				
I-7	Ensure that the cabinet is cleaned with a mild soap solution	Page 10				
I-8	Ensure that the cabinet has stood upright for 24 hours if the cabinet has been laying down.	Page 10				
I-9	Ensure that the cabinet is levelled if it is equipped with legs.	Page 11				
I-10	Ensure a level surface if the cabinet is equipped with wheels/castors.	Page 11				
I-11	If equipped with wheels/castors: Ensure wheels/castors are locked after positioning	Page 11				
I-12	If equipped with drawers and/or glass door: Ensure that tilt-bracket is mounted.	Page 12				
I-13	Ensure a distance of 15-75 mm between cabinet and back wall.	Page 13				
I-14	Ensure that there is a minimum gap of 30 mm between cabinets.	Page 14				
I-15	Ensure that the upper part of the cabinet is not covered.	Page 14				
I-16	Ensure that electrical appliances are not being used inside the cabinet.	Page 14				

Model: _____

SN: _____

Installation Qualification - IQ

ID	Description of installation	Reference in manual	Comply		Attachment	Notes
			Yes	No		
I-17	Ensure connection from voltage-free contact to external monitoring system	Page 15				
I-18	Ensure that the inner doors can operate in accordance with the instructions.	N/A				
I-19	Ensure the correct electrical connection (compare local values with type/number plate)	Page 16				
I-20-1	Ensure that the power cord is secured by the preload cover	Page 16				
I-20-2	Ensure that the power cord is secured by the preload hanger	N/A				
I-21	Mark the power cord with: "Do not separate when energized".	N/A				
I-22-1	Ensure equipotential bonding (applicable for ATEX Cat. 3 Zone 2 areas)	Page 17				

Model: _____

SN: _____

Operation Qualification – OQ

ID	Description of operation	Reference in manual	Comply		Attachment	Notes
			Yes	No		
O-1	Turn on the cabinet – Display test (software version and variant).	Page 34				
O-2	Set/adjust set-point temperature.	Page 34				
O-3	Set/adjust LhL – Upper alarm limit (local).	Page 38				
O-4	Set/adjust LLL – Lower alarm limit (local).	Page 38				
O-5	Set/adjust Lhd – Delay of the upper alarm limit (local).	Page 39				
O-6	Set/adjust LLd – Delay of the lower alarm limit (local).	Page 39				
O-7	Activate / deactivate dA – Door alarm (local).	Page 40				
O-8	Set/adjust dAd – Delay of the door alarm (local).	Page 40				
O-9	Activate / deactivate BU – Acoustic alarms (local).	Page 41				
O-10	Set/adjust EhL – Upper alarm limit (external).	Page 42				
O-11	Set/adjust ELL – Lower alarm limit (external).	Page 42				
O-12	Set/adjust Ehd – Delay of the upper alarm limit (external).	Page 43				
O-13	Set/adjust ELd – Delay of the lower alarm limit (external).	Page 43				
O-14	Activate / deactivate dA – Door alarm (external)	Page 44				
O-15	Set/adjust dAd – Delay of the door alarm (external).	Page 44				
O-16	Activate / deactivate BU – Acoustic external alarms.	Page 45				
O-17	Set/adjust defrost cycles (dEF) per 24 hours (factory setting: 4).	Page 49				
O-18	Select reference sensor for the display (dPS) (A or E).	Page 50				

Model: _____

SN: _____

Approval of the test results – Installation Qualification (IQ)

- The steps in the Installation Qualification – IQ were completed with positive results
- The steps in the Installation Qualification – IQ were completed with negative results

ID of steps with negative results: _____

Approval of the test results – Operation Qualification (OQ)

- The steps in the Operation Qualification – OQ were completed with positive results
- The steps in the Operation Qualification – OQ were completed with negative results

ID of steps with negative results: _____

Organisation/Responsible party: _____

Trainer/Responsible party: _____

Stamp & Signature

Stamp & Signature

Tel.

Tel.

e-mail

e-mail

Location & Date

Location & Date

Model: _____

SN: _____

Performance Qualification

Organisation:

Location of installation:

Model: _____

SN: _____

Item number: _____
(manual)

The PQ consists of inspections of the correct operation of the cabinet under predefined conditions and procedures.

Prerequisites for the PQ are IQ (Installation Qualification) and OQ (Operation Qualification), these must be concluded successfully prior to the initiation of the PQ.

Person responsible for the cabinet:

Name: _____

Date: _____

Signature: _____

Person responsible for the test:

Name: _____

Date: _____

Organisation: _____

Signature: _____

Person responsible for verification of the test:

Name: _____

Date: _____

Organisation: _____

Signature: _____

Test duration:

Initiation (date/time): _____

Conclusion (date/time): _____

Date: _____

Organisation: _____

Signature: _____

Model: _____

SN: _____

Deviations from the specifications dictated in the PQ, are to be reported in the deviation report.
 The PQ is concluded if all criteria of acceptance are approved and the possible deviations are rectified or accepted.

Measurements – Prerequisites			
		Yes	No
P-1	The cabinet must be empty while conducting tests, ie without interior fittings such as drawers, shelves etc. Attachment: Notes:		
P-2	The measurements must be conducted in accordance to IEC 60068-3-5. Attachment: Notes:		
P-3	The positioning of the sensors in the cabinet must be documented with a sketch and/or a photograph. Attachment: Notes:		

Name: _____ Signature: _____ Approved (Yes/No): _____ Date: _____

Conducted by: _____

Inspected/verified by: _____

Model: _____ SN: _____

Deviations from the specifications dictated in the PQ, are to be reported in the deviation report.
 The PQ is concluded if all criteria of acceptance are approved and the possible deviations are rectified or accepted.

Measurements – Prerequisites			
		Yes	No
P-4	Measurements made during the PQ tests must be documented and attached to the PQ. Attachment: Notes:		
P-5	Specify setpoint temperature: _____ °C Specify the ambient temperature: _____ °C Attachment: Notes:		
P-6	Allowed tolerances – <i>Select the tolerance, according to the model being tested.</i> <i>Find model-specific tolerances in appendix.</i> Tolerance: +/- _____ K Attachment: Notes:		

Name: _____ Signature: _____ Approved (Yes/No): _____ Date: _____
 Conducted by: _____
 Inspected/verified by: _____
 Model: _____ SN: _____

Deviations from the specifications dictated in the PQ are to be reported in the deviation report.
 The PQ is concluded if all criteria of acceptance are approved and the possible deviations are rectified or accepted.

Measurements – Temperature stabilisation			
		Yes	No
P-7	<p>The test is intended to provide substantiation for the temperature stability inside the cabinet during normal operation.</p> <p>The temperature inside the cabinet must be stabilised – Where all the points in the working space have reached and maintained the same temperature.</p> <p>When the system is stable, document ordinary operation of the cabinet at the setpoint temperature and ambient temperature specified in P-5.</p> <p>Duration: _____</p> <p>The measurements throughout the operation test, must be documented and attached the PQ.</p> <p>Attachment:</p> <p>Notes:</p>		
P-8	<p>Are the measurements inside the allowed tolerances specified in P-6 ?</p> <p>Attachment:</p> <p>Notes:</p>		

Name: _____ Signature: _____ Approved (Yes/No): _____ Date: _____

Conducted by: _____

Inspected/verified by: _____

Model: _____ SN: _____

Deviations from the specifications dictated in the PQ are to be reported in the deviation report.
 The PQ is concluded if all criteria of acceptance are approved and the possible deviations are rectified or accepted.

Measurements – Door opening test			
		Yes	No
P-9	<p>The test is intended to provide substantiation for the temperature recovery time inside the cabinet subsequently after a door opening.</p> <p>The temperature inside the cabinet must be stabilised – Where all the points in the working space have reached and maintained the same temperature, the setpoint temperature is specified in P-5.</p> <p>When the system is stable, open the door at 90° for 60 seconds.</p> <p>The measurements, throughout the door opening test, must be documented and attached the PQ.</p> <p>Duration: _____</p> <p>Attachment:</p> <p>Notes:</p>		
P-10	<p>Has the setpoint temperature specified in P-5, measured in the absolute centre of the cabinet, been achieved within the set time-frame specified in the appendix?</p> <p>Attachment:</p> <p>Notes:</p>		

Name: _____ Signature: _____ Approved (Yes/No): _____ Date: _____

Conducted by: _____

Inspected/verified by: _____

Model: _____ SN: _____

Deviations from the specifications dictated in the PQ, are to be reported in the deviation report.
 The PQ is concluded if all criteria of acceptance are approved and the possible deviations are rectified or accepted.

Measurements – Pull-down			
		Yes	No
P-11	<p>The test is intended to provide substantiation for the time it takes for the inside of the cabinet to reach the setpoint temperature specified in P-5. The initial temperature in the working space is the ambient temperature specified in P-5. The temperature inside the cabinet must be stabilised in all points of the working space.</p> <p>When the system is stable, turn on the power to the cabinet.</p> <p>The measurements, throughout the pull-down test, must be documented and attached the PQ.</p> <p>Duration: _____</p> <p>Attachment:</p> <p>Notes:</p>		
P-12	<p>The time it takes the inside of the cabinet to achieve the setpoint temperature measured in the absolute centre, must not exceed the time-frame specified in the appendix.</p> <p>Have the criteria been met?</p> <p>Attachment:</p> <p>Notes:</p>		

Name: _____ Signature: _____ Approved (Yes/No): _____ Date: _____

Conducted by: _____

Inspected/verified by: _____

Model: _____ SN: _____

Deviations from the specifications dictated in the PQ, are to be reported in the deviation report.
 The PQ is concluded if all criteria of acceptance are approved and the possible deviations are rectified or accepted.

Measurements - Hold-over		Yes	No
P-13	<p>The test is intended to provide substantiation for the time it takes for the temperature inside the cabinet to reach the end temperature specified in the appendix. Ambient temperature and setpoint temperature is specified in P-5.</p> <p>The temperature inside the cabinet must be stabilised - Where all the points in the working space have reached and maintained the same temperature throughout, the tolerances are specified in P-6.</p> <p>When the system is stable, turn off the power to the cabinet.</p> <p>The measurements, throughout the hold-over test, must be documented and attached the PQ.</p> <p>Attachment:</p> <p>Notes:</p>		
P-14	<p>The times it takes the inside of the cabinet to reach the end temperature, must at least be the time specified in the appendix.</p> <p>Duration: _____</p> <p>Have the criteria been met?</p> <p>Attachment:</p> <p>Notes:</p>		

Conducted by: _____ Name: _____ Signature: _____ Approved (Yes/No): _____ Date: _____

Inspected/verified by: _____

Model: _____ SN: _____

Deviation Report

Deviations to the criteria of acceptance are to be documented in the deviation report. A separate deviation report shall be made for each deviation. Mark the entry with the relevant "P-ID" specified in the left column in the test specifications.

P-ID: _____

Description of deviation:

Extent to which the deviation has been alleviated:

Additional notes:

Person responsible for test:

Name: _____

Date: _____

Organisation: _____

Signature: _____

Person responsible for verification of test:

Name: _____

Date: _____

Organisation: _____

Signature: _____

Model: _____

SN: _____

Approval of the test results – Performance Qualification (PQ)

- The steps in the Performance Qualification – PQ were completed with positive results
- The steps in the Performance Qualification – PQ were completed with negative results

ID of steps with negative results: _____

Organisation/Responsible party: _____

Trainer/Responsible party: _____

Stamp & Signature _____

Stamp & Signature _____

Tel. _____

Tel. _____

e-mail _____

e-mail _____

Location & Date _____

Location & Date _____

Model: _____

SN: _____

Appendix

	Tolerances	Door opening recovery time (minutes) ***	Permissible deviation	Pull-down (minutes)	Permissible deviation	Hold-over range*	Hold-over	Permissible deviation
Refrigerators (RR)								
BioMidi								
425 (Solid door)	+/- 3K	3 min.	-	20 min.	-	5 °C → 10 °C	63 min.	-
425 (Glass door)	+/- 3K	4 min.	-	25 min.	-	5 °C → 10 °C	37 min.	-
625 (Solid door)	+/- 3K	3 min.	-	20 min.	-	5 °C → 10 °C	63 min.	-
625 (Glass door)	+/- 3K	4 min.	-	25 min.	-	5 °C → 10 °C	37 min.	-
Refrigerators with extended refrigeration (ER)								
BioPlus								
500 (Solid door)	+/- 2K	3 min.	-	22 min.	-	5 °C → 10 °C	72 min.	-
500 (Glass door)	+/- 2K	4 min.	-	28 min.	-	5 °C → 10 °C	42 min.	-
600D/600W (Solid door)	+/- 2K	3 min.	-	20 min.	-	5 °C → 10 °C	70 min.	-
600D/600W (Glass door)	+/- 2K	4 min.	-	25 min.	-	5 °C → 10 °C	41 min.	-
660D/660W (Solid door)	+/- 2K	3 min.	-	20 min.	-	5 °C → 10 °C	70 min.	-
660D/660W (Glass door)	+/- 2K	4 min.	-	25 min.	-	5 °C → 10 °C	41 min.	-
930 (Solid door)	+/- 2K	5 min.	-	22 min.	-	5 °C → 10 °C	65 min.	-
1270/1400 (Solid door)	+/- 2K	5 min.	-	23 min.	-	5 °C → 10 °C	78 min.	-
1270/1400 (Glass door)	+/- 2K	7 min.	-	29 min.	-	5 °C → 10 °C	45 min.	-

*) The temperature span between the initial temperature and the end temperature in the hold-over test P-13,14.

**) Please contact your local distributor for current information.

***): 90° opening 1 minute

	Ambient Temperature	Setpoint temperature
RR/ER	+25 °C	+5 °C

Name: _____ Signature: _____ Approved (Yes/No): _____ Date: _____

Conducted by: _____

Inspected/verified by: _____

Model: _____ SN: _____

Appendix

	Tolerances	Door opening recovery time (minutes) ***	Permissible deviation	Pull-down (minutes)	Permissible deviation	Hold-over range*	Hold-over	Permissible deviation
FREEZERS (RF)								
BioMidi								
425	+/- 5K	9 min.	-	45 min.	-	-20 °C → -10 °C	55 min.	-
625	+/- 5K	8 min.	-	42 min.	-	-20 °C → -10 °C	55 min.	-
BioPlus								
500	+/- 5K	7 min.	-	45 min.	-	-20 °C → -10 °C	55 min.	-
600D/600W	+/- 5K	7 min.	-	42 min.	-	-20 °C → -10 °C	55 min.	-
660D/660W	+/- 5K	7 min.	-	42 min.	-	-20 °C → -10 °C	55 min.	-
930	+/- 5K	-	-	76 min.	-	-20 °C → -10 °C	63 min.	-
1270/1400	+/- 5K	10 min.	-	45 min.	-	-20 °C → -10 °C	58 min.	-
EXTENDED FREEZERS (EF)								
BioMidi								
425	+/- 9K	40 min.	-	107 min.	-	-40°C → -10 °C	108 min.	-
BioPlus								
600W/660W	+/- 10K	30 min.	-	215 min.	-	-35°C → -10 °C	170 min.	-

*)): The temperature span between the initial temperature and the end temperature in the hold-over test P-13,14.

**)): Please contact your local distributor for current information.

***): 90° opening 1 minute

	Ambient Temperature	Setpoint temperature
RF	+25 °C	-20 °C
EF (425)	+25 °C	-40 °C
EF (600W/660W)	+25 °C	-35 °C

Name: _____ Signature: _____ Approved (Yes/No): _____ Date: _____

Conducted by: _____

Inspected/verified by: _____

Model: _____ SN: _____

Index

A	
Access port	60
Anti tilt bracket	12
C	
Cabinet components	6
Cleaning	53,155,156
Connection to power	16
D	
Datasheet	63
Declaration of conformity	135
Defrost	49,57
Digital display	34
Display sensor	50
Disposal	62
Door gasket	54
Door lock	59
Door self-closing mechanism	58
Dry cool	37
E	
Equipotential bonding	18
Error codes	36
External alarm settings	42
F	
FAQ	160
G	
General info	55
I	
Important	61
Initial setup	10
Installation	10
IQ, OQ, PQ	162,170
L	
Load line	52
Local alarm settings	38
Low-temperature protection	51
M	
Maintenance	53,152,153
Menu	35
O	
Options assembly	20
Ordinary use	52
P	
Parameter settings	46
Piping diagram	139
Q	
Quick Guide	2
R	
Responsibility	55
S	
Safety	5
Sensor offset	46
Start-up	34
Surroundings	13
Symbols	5
T	
Table of content	4
Type/number plate	56
V	
Voltage-free contact	15
W	
Wiring diagram	141



Gram Scientific Aps
Aage Grams Vej 1 · 6500 Vojens · Denmark
Tel: +45 73 2 0 13 00
e-mail: info@gram-bioline.com
www.gram-bioline.com

