

BioCompact II

INSTRUCTIONS FOR USE

MODELS: 210, 310, 410, 610

Original Instructions for use

Item No.: 765042589
Revision No.: 20250303
Language: English

Quick guide – BioCompact II

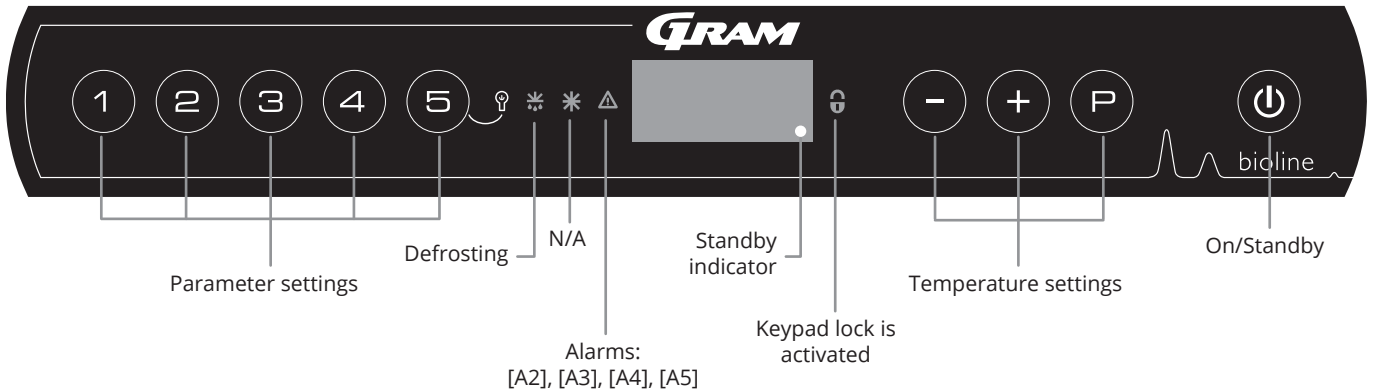

On/Standby

Press the key to turn the cabinet on. Press the key for 6 seconds to switch to standby. The software version of the cabinet will be shown when turning the cabinet on, followed by the software variant. The cabinet is ready when the temperature is displayed. The cabinet will automatically start a defrost-cycle when turned on, and terminate it again after a system check.

Setting the temperature

Temperature adjustments are done by holding the key and pressing either or . Confirm the settings by letting go of the keys.

User menu and alarm settings

Menu access + →	↓	→		Display code and its message
Local alarm settings	LAL	LhL	[° C]	Upper temperature limit. Code for activated alarm [A2]
		LLL	[° C]	Lower temperature limit. Code for activated alarm [A3]
		Lhd	[min.]	Delay of upper temperature limit
		LLd	[min.]	Delay of lower temperature limit
		dA	On/off	Door alarm. Code for activated alarm [A1]. [1=on/0=off]
		dAd	[min.]	Delay of door alarm
		BU	On/off	Acoustic signal for alarm codes [A1], [A2] and [A3]. [1=on/0=off]
Offset of sensors	CAL	cA	[K]	Offset setting for A-sensor. Reference sensor for the refrigeration system
		cE	[K]	Offset setting for E-sensor. Reference sensor for the display and alarms
		cF	[K]	Offset setting for F-sensor. Reference sensor for the low-temperature protection
Low-temperature protection	FP	ACt	On/off	Activation/deactivation of low-temperature protection
		tES	On	Test of low-temperature protection
		SEt	[° C]	Setting of the cut-off temperature for the low-temperature protection
		PrE	[...]	Read-out of the real-time temperature of the F-sensor
		ALL		Activation of escorted alarm limits. [FAS]=locked limits/[ESC]=follows setpoint
		dEF		Number of defrosts per 24 hours (4 is factory setting)
		dPS		Reference sensor for the display (A, E or F)



Lighting inside the cabinet (only applicable to BioCompact II cabinets with glass doors)

The settings for the lighting inside the cabinet can be changed by pressing and holding for 3 seconds.

There are two settings:

- 1) Light turns on when the door is open (off when closed)
- 2) Light is always on

Example: Setting the upper limits for the alarms; LhL

- ↳ Press and hold (P) + (1) until the display shows LAL
- ↳ Press (P) to select LAL, LhL is now shown in the display
- ↳ Press (P) to select LhL, 25 is shown in the display
- ↳ Press (-) or (+) to set the desired value for the upper temperature limit
- ↳ Press (P) to confirm the set value
- ↳ Press (U) to return to LhL
- ↳ Press (+) to reach the next level, LLL
- ↳ Lhd, LLd, dA, dAd and BU are located on the same level
- ↳ Press (U) three times to leave the user menu

Alarms

Alarm codes	[A1]	Door alarm
	[A2]	The upper alarm limits, (LhL) is or has been activated
	[A3]	The lower alarm limits, (LLL) alarm is or has been activated

Acknowledging an acoustic alarm

Alarm code [A1]: Press (P) to acknowledge. Temperature alarm codes [A2] and/or [A3]: Flashes in the display. Press (P) to acknowledge. The display will continue to flash if the temperature is outside the alarm limits.

Latching alarms: [A2], [A3], [A4], [A5]

Due to the potential implications of alarms, the red alarm triangle icon will turn on along with the corresponding alarm code in the display. The alarm state will remain on until it is acknowledged by pressing (P).

Read-out of the max./min. temperature

Read the highest recorded temperature inside the cabinet by holding down (+). Read the lowest recorded temperature inside the cabinet by holding down (-).

Reading the alarm history - Example [A2]

[A2] Flashes in the display – This means that the temperature has exceeded the set value for the upper temperature limit, LhL. Press (P) to acknowledge the [A2]. The display continues to flash, indicating that there is information in the alarm history. Press (+), Htt (High temperature time) is shown. Press (P) to see for how long the temperature was above the set alarm limit. Press (U) to return to Htt. Press (+) to reach Ht (Highest temperature). Press (P) to read the highest recorded temperature during Htt. Press (U) to return to Ht and press (U) again to leave the alarm history function. The procedure for reading an [A3] alarm is identical, apart from entering the alarm history with the (-) key. When reading out temperatures below set limits, the parameters are Ltt and Lt. A flashing display with no alarm codes indicates that the alarm codes have been acknowledged, but the alarm system contains information.

Resetting the alarm temperature and the alarm history

Resetting of the max./min. temperature and the alarm history is done by holding (-) and (+) for more than three seconds. An acoustic signal will be given when reset is complete.

Sensor read-out and error codes

Menu access (P) + (5) →	↵	(P) → [° C]	Display code and its message	
Sensor for refrigeration system	P-A	Value on sensor for refrigeration system	F1	Error on sensor for refrigeration system
Sensor for evaporator	P-b	Value for evaporator sensor	F2	Error on evaporator sensor
Sensor for condensor	P-C	Value for condensor sensor	F3	Error on condensor sensor
Sensor for display and alarms	P-E	Value for display and alarms sensor	F5	Error on sensor for display and alarms
Sensor for low-temperature protection	p-F	Value of sensor for low-temperature protection	F6	Error on sensor for low-temperature protection
F7 indicates that the temperature of the condensor is too high. Turn off the cabinet and check that the condenser is not covered, and ensure that the condenser (and possibly filter) is clean. Service is required if the problem is not alleviated			F7	Overheated condensor
Open door indicator. Alarm [A1] will activate if the door is open longer than alarm limits			- 0 -	Door open

Table of content

Quick guide – BioCompact II	2	Datasheet	64
Table of content	4	BioCompact II 210, 310, 410, 210/210, 310/210	64
Safety	5	BioCompact II RR210 H	65
Before you proceed	5	BioCompact II RR310 H	66
Cabinet components	6	BioCompact II RR410 H	67
BioCompact II 210, 310, 410, 210/210, 310/210	6	BioCompact II RF210 H	68
BioCompact II 610	8	BioCompact II RF310 H	68
Installation	10	BioCompact II RF410 H	69
Initial setup steps	10	BioCompact II RR210/RR210 H	70
Reversal of door	13	BioCompact II RR210/RF210 H	71
Anti tilt bracket	16	BioCompact II RF210/RF210 H	72
Wall mounting	17	BioCompact II RR310/RF210 H	73
Surroundings	18	BioCompact II RR210 G	74
Voltage-free contact	20	BioCompact II RR310 G	75
Connection to power	22	BioCompact II RR410 G	76
Equipotential bonding	25	BioCompact II RF210 G	77
Options assembly	26	BioCompact II RF310 G	77
Introduction	26	BioCompact II RF410 G	78
ABS drawer	27	BioCompact II RR210/RR210 G	79
Aluminium drawer	29	BioCompact II RR210/RF210 G	80
Wire basket	31	BioCompact II RF210/RF210 G	81
Wire basket 300 mm	32	BioCompact II RR310/RF210 G	82
Wire shelf	33	BioCompact II RR610	83
Wire shelf 300 mm	34	BioCompact II RR610 H	84
Perforated shelf	35	BioCompact II RF610 H	85
Start-up	36	BioCompact II RR610 G	86
The digital display	36	BioCompact II RF610 G	87
Walkthrough of menu	37	Declaration of conformity	88
Error codes	38	BioCompact II 210, 310, 410, 210/210 & 310/210	88
Local alarm settings	39	BioCompact II 610	89
Local high alarm	39	BioCompact II 210, 310, 410, 210/210 & 310/210 –	
Local low alarm	39	Accessories code 69	90
Local high alarm delay	40	BioCompact II 610 – Accessories code 69	91
Local low alarm delay	40	Wiring diagram	92
Activate/deactivate of local door alarm	41	BioCompact II 210, 310, 410	92
Delay for local door alarm	41	BioCompact II 210, 310, 410 – With LTP	93
Local acoustic settings	42	BioCompact II RR610 – With solid door	94
External alarm settings	43	BioCompact II RF610	95
External high alarm	43	BioCompact II RR610 – With glass door	96
External low alarm	43	BioCompact II RR610 – With solid door, with LTP	97
External high alarm delay	44	BioCompact II RR610 – With glass door, with LTP	98
External low alarm delay	44	Piping diagram	99
Activation/deactivation of external door alarm	45	BioCompact II	99
External door alarm delay alarm	45	General maintenance information	100
External acoustic settings	46	Maintenance plan	101
Parameter settings	47	General cleaning information	103
Sensor offset	47	Cleaning plan	104
Escorted/set alarm limits	49	FAQ	108
Defrosts/24 hours	50	IQ & OQ	110
Display sensor	51	Installation Qualification	110
Electric low-temperature protection	52	Operation Qualification	110
Ordinary use	53	PQ	118
Load line	53	Performance Qualification	118
Door lock	55	Index	130
Regular maintenance	56		
Cleaning	56		
Door gasket	57		
General info	58		
Service	58		
Type/number plate	59		
Defrost water	60		
Access port	61		
Important	62		
Disposal	63		

Copyright © 2006- Gram BioLine, a division of Gram Scientific ApS, Denmark. All rights reserved.

The content of this publication is owned by Gram BioLine, unless otherwise noted, and is protected by Danish and international copyright laws and provisions. Information and images may not be used, copied or transferred without the express written permission of Gram BioLine.



Manufactured by
Gram Scientific ApS
 Aage Grams Vej 1 · 6500 Vojens · Denmark
 Tel: +45 73 20 13 00
 e-mail: info@gram-bioline.com · www.gram-bioline.com

Before you proceed

Make sure to read the instructions for use thoroughly before using the cabinet for the first time.
In the event of need for product support, do not hesitate to contact us at: support@gram-bioline.com

This instructions for use is intended for the following product series:

BioCompact II

We recommend that you read this instructions for use thoroughly before using the cabinet for the first time. Gram BioLine does not guarantee safe operation if the cabinet is used for anything other than its intended use. Contents of the instructions for use can be subject to change without notice. No part of this instructions for use may be reproduced in any form without expressed written consent of Gram BioLine. Gram BioLine guarantees the cabinet under certain warranty conditions. Gram BioLine is in no way responsible for any loss or damage of content. This instructions for use should be considered as an integral part of the cabinet, and should be stored close to the cabinet and be easily accessible. If the instructions for use is lost, please refer to your local distributor or Gram BioLine for a replacement. For current versions of the manual, please go to www.gram-bioline.com.

Intended use

BioCompact II refrigerators (RR) and freezers (RF) are designed and manufactured to provide safe and precise conditions for the items stored.

The cabinets are designed for the following operating ranges:

RR +2/+20 °C

RF -25/-5 °C

at the maximum ambient temperature specified in this instructions for use, and a maximum relative humidity of 70%. The user must ensure that the cabinet is used in accordance with its intended use.

Abnormal use or use conflicting with the intended use or guidelines stipulated in the product documentation can lead to: danger to patient safety, damage to stored items, damage to cabinet, and/or danger to user.

Gram BioLine equipment is designed to be used in a system with monitored additional independent alarms to ensure timely reaction to alarms and thereby maximum item safety.

When storing valuable or temperature-sensitive materials or products, it is advisable to employ a continuously monitoring autonomous alarm system. This alarm system should be designed in a manner that allows authorised individuals to promptly detect each alarm state and take the necessary corrective actions.

Symbols used throughout the instructions for use



Hazard



Risk of fire/flammable materials



Risk of electric shock



Risk of explosion/explosive materials



Risk of material damage



Info



Risk of personal injury



ATEX information



Risk of burning/freezing

Cabinet components

BioCompact II 210, 310, 410, 210/210, 310/210

This part describes the main components pertinent to the user.

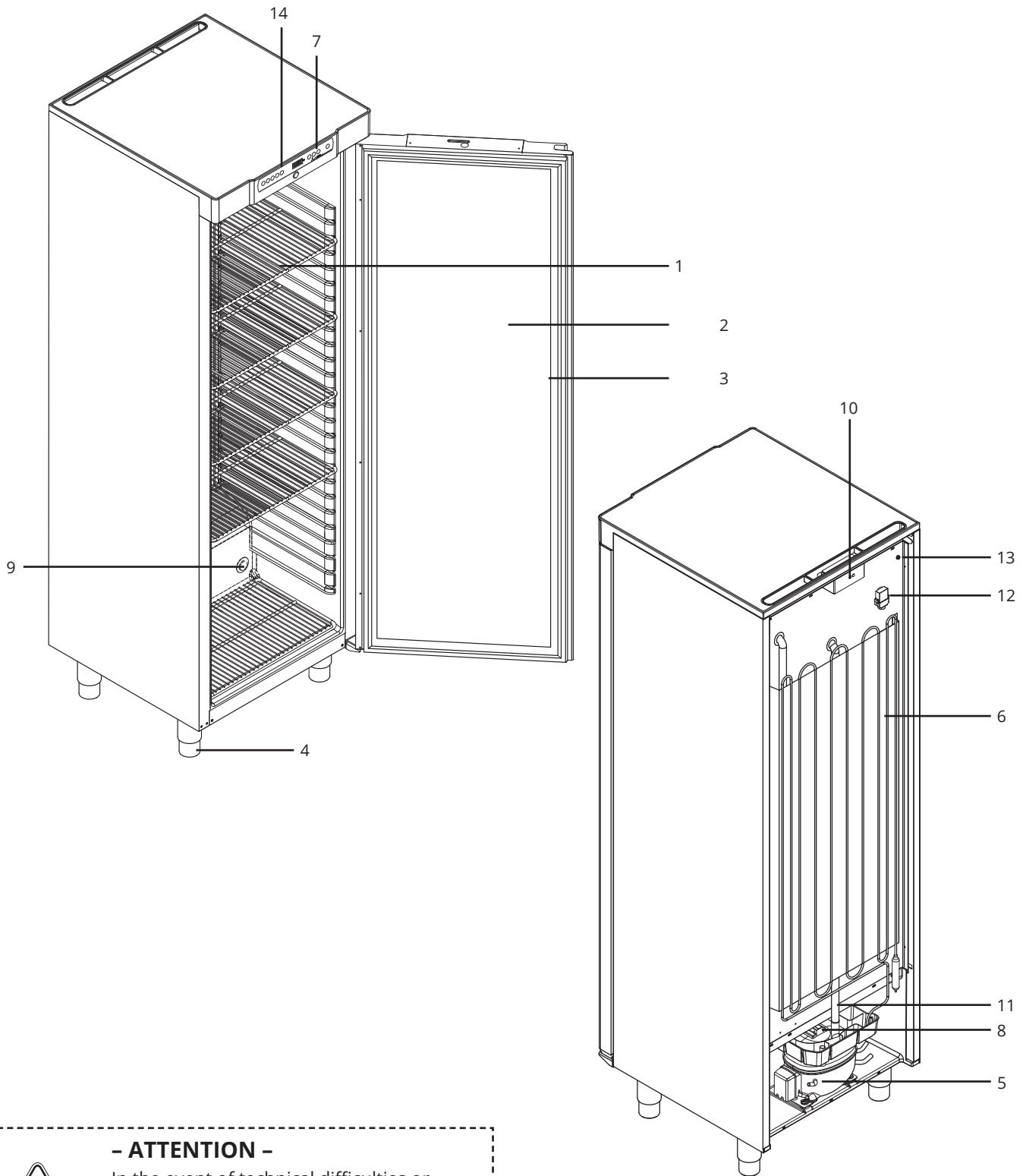

- ATTENTION -

In the event of technical difficulties or breakdown, always contact Gram BioLine technical support or a Gram BioLine authorised service partner.

- 1. Shelves, drawers and wall rails**
Ensure that the shelves are mounted correctly, before exerting load on them.
- 2. Door**
Ensure that the door is closed completely after use.
To minimise fluctuations in temperature, make the door openings as brief as possible.
- 3. Door gasket**
Ensure that the gasket is pliable and in good working order.
Keep the door gasket clean, find instructions in this instructions for use.
- 4. Base of cabinet**
Ensure cabinets with legs are levelled properly and cabinets with castors are placed on a level surface and locked as specified in this instructions for use.
- 5. Compressor**
Ensure it is not dented or shows any other signs of damage.
- 6. Condenser**
Ensure it is not dented or shows any other signs of damage.
- 7. Controller**
Enclosure for the controller, sensors and other parts that monitor and manage the refrigeration system.
Ensure it is not dented or shows any other signs of damage.
- 8. Re-evaporation tray**
Ensure it is not cracked or shows any other signs of damage.
It is recommended to clean it before applying power to the cabinet for first the time.
- 9. Access port**
Used to lead sensors and similar into the cabinet.
Ensure that the access port is sealed properly prior to start-up.
- 10. Preload cover to access mains terminal and voltage-free contact**
Used to connect to an external alarm system.
Instructions for connection is found in this instructions for use.
Remember to set the external alarms (EAL).
- 11. Defrost water tube**
Outlet for the defrost water coming from the evaporator tray inside the cabinet.
Ensure it is not damaged or shows signs of damage.
- 12. Pressure equalisation valve**
Do not use as access port. Keep it as free of ice as possible.
- 13. Equipotential bonding**
To ensure compliance with ATEX regulations EN 60079-14.
See installation section for specifications.
- 14. Digital display for controller**
Use the display to show the cabinet temperature and, to set the parameters described in this manual.



- ATTENTION -

If parts show signs of damage; do not use the cabinet and contact Gram BioLine or supplier for further aid.

BioCompact II 610

This part describes the main components pertinent to the user.

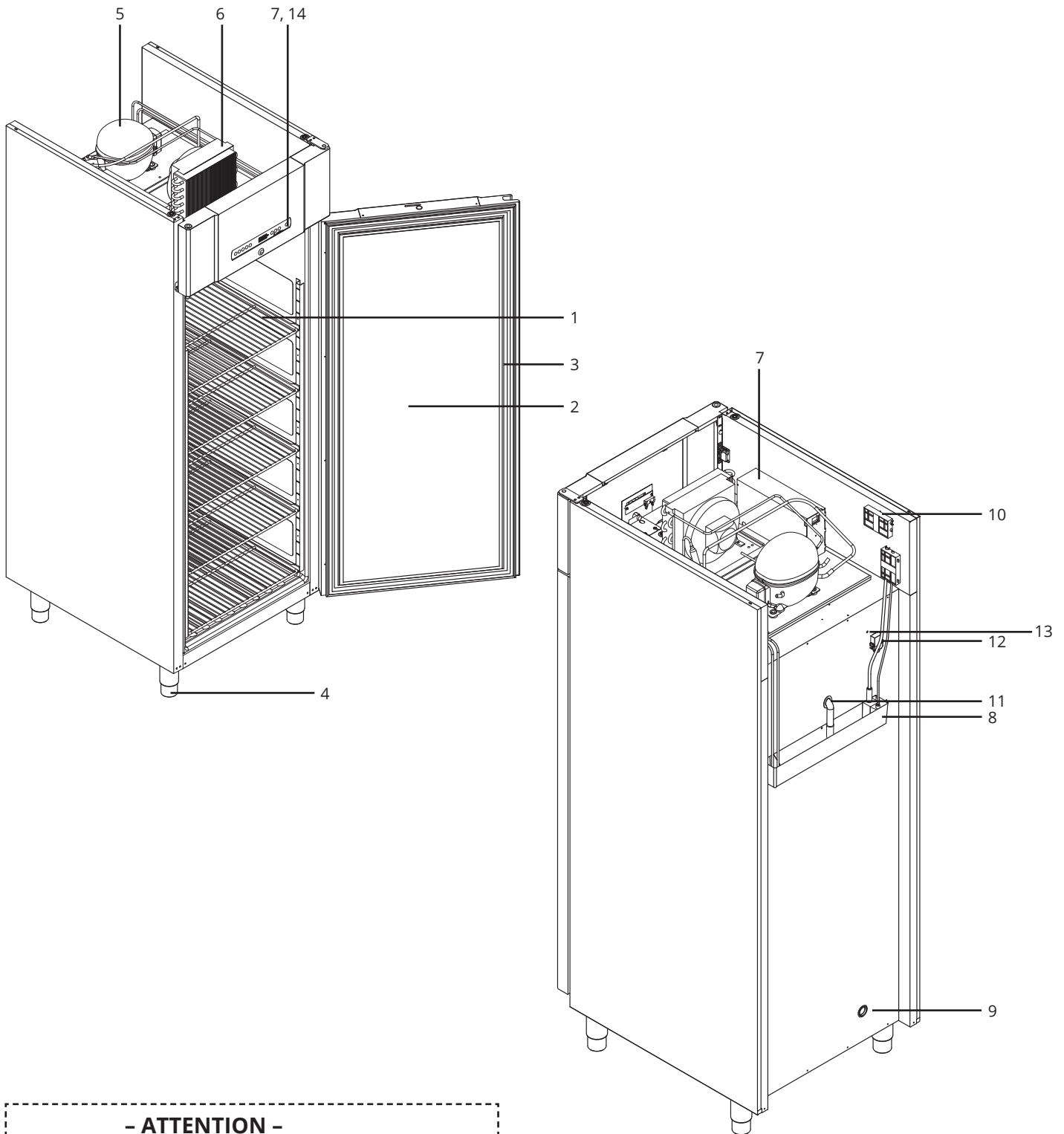

- ATTENTION -

In the event of technical difficulties or breakdown, always contact Gram BioLine technical support or a Gram BioLine authorised service partner.

1. **Shelves, drawers and wall rails**
Ensure that the shelves are mounted correctly, before exerting load on them.
2. **Door**
Ensure that the door is closed completely after use.
To minimise fluctuations in temperature, make the door openings as brief as possible.
3. **Door gasket**
Ensure that the gasket is pliable and in good working order.
Keep the door gasket clean, find instructions in this instructions for use.
4. **Base of cabinet**
Ensure cabinets with legs are levelled properly and cabinets with castors are placed on a level surface and locked as specified in this instructions for use.
5. **Compressor**
Ensure it is not dented or shows any other signs of damage.
6. **Condenser**
Ensure it is not dented or shows any other signs of damage.
7. **Controller**
Enclosure for the controller, sensors and other parts that monitor and manage the refrigeration system.
Ensure it is not dented or shows any other signs of damage.
8. **Re-evaporation tray**
Ensure it is not cracked or shows any other signs of damage.
It is recommended to clean it before applying power to the cabinet for first the time.
9. **Access port**
Used to lead sensors and similar into the cabinet.
Ensure that the access port is sealed properly prior to start-up.
10. **Preload cover to access mains terminal and voltage-free contact**
Used to connect to an external alarm system.
Instructions for connection is found in this instructions for use.
Remember to set the external alarms (EAL).
11. **Defrost water tube**
Outlet for the defrost water coming from the evaporator tray inside the cabinet.
Ensure it is not damaged or shows signs of damage.
12. **Pressure equalisation valve**
Do not use as access port. Keep it as free of ice as possible.
13. **Equipotential bonding**
To ensure compliance with ATEX regulations EN 60079-14.
See installation section for specifications.
14. **Digital display for controller**
Use the display to show the cabinet temperature and, to set the parameters described in this manual.



- ATTENTION -

If parts show signs of damage; do not use the cabinet and contact Gram BioLine or supplier for further aid.

Installation

Initial setup steps

This part of the instructions for use describes how to set up the cabinet.



- I-1*:** Due to safety and operating considerations, the cabinet must not be used outdoors.
- I-2*:** The cabinet should be installed in a dry and sufficiently ventilated area.
- I-3*:** To ensure efficient operation, the cabinet should not be installed in direct sunlight or close to heat sources.



The cabinet interior must not be exposed to corrosive atmospheres.

I-4*: Ambient operating temperature range

Cabinet	Minimum ambient operating temperature	Maximum ambient operating temperature
BioCompact II 210, 310, 410, 210/210, 310/210		
RR with solid door	+10 °C	+35 °C
RR with glass door	+10 °C	+32 °C
RF	+10 °C	+35 °C
BioCompact II 610		
RR with solid door	+10 °C	+43 °C
RR with glass door	+10 °C	+38 °C
RF	+10 °C	+43 °C



Ensure the use of correct personal protective equipment such as gloves and goggles, when handling equipment to support safe and efficient use.



I-5*: Avoid placement of the cabinet in a chloric/acidic environment due to risk of corrosion.



I-6*: The cabinet is shipped with a protective film that should be removed prior to use.

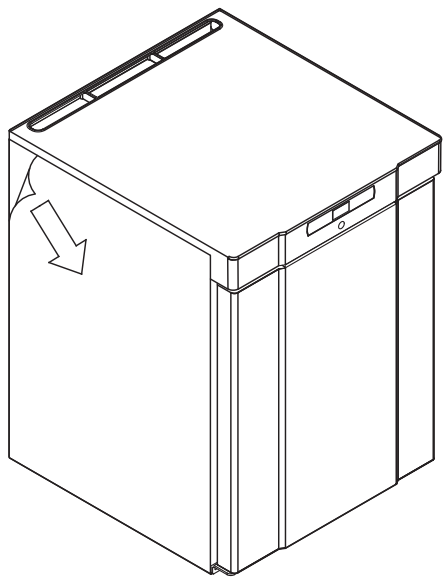

**- WARNING -
Potential electrostatic hazard**

Removing protective packaging and film may cause electrostatic discharge. Protective packaging and film shall not be removed in ATEX zones.



I-7*: Clean the cabinet with a mild soap solution prior to use.



I-8*: The cabinet is only allowed to lay down for very short durations (for instance handling through a doorway). If the cabinet has been laying down, the cabinet must stand up-right for at least 24 hours prior to use. This enables oil in the compressor to flow back into place.

I-9*: Cabinets equipped with should be levelled as shown in the illustrations below.

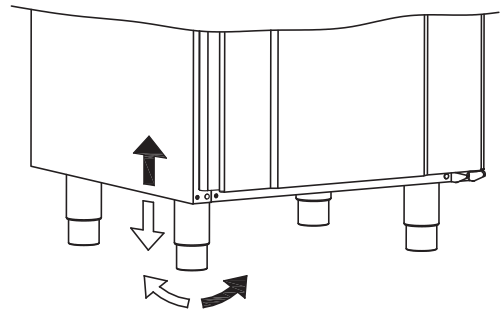
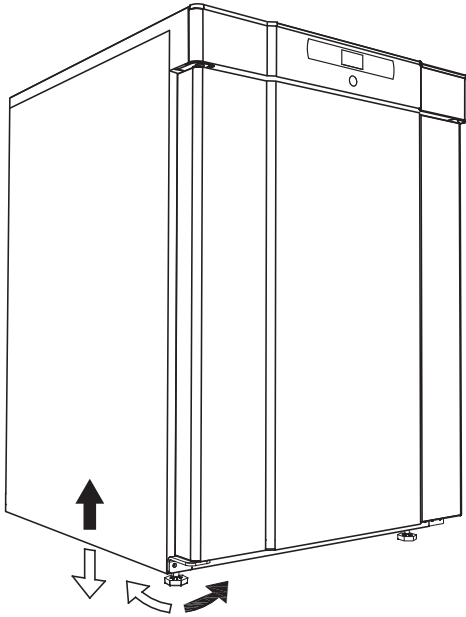

I-10-11*: For cabinets equipped with castors, the floor must be level to ensure stable positioning and safe use. When the cabinet is positioned, the two front castors should be locked.

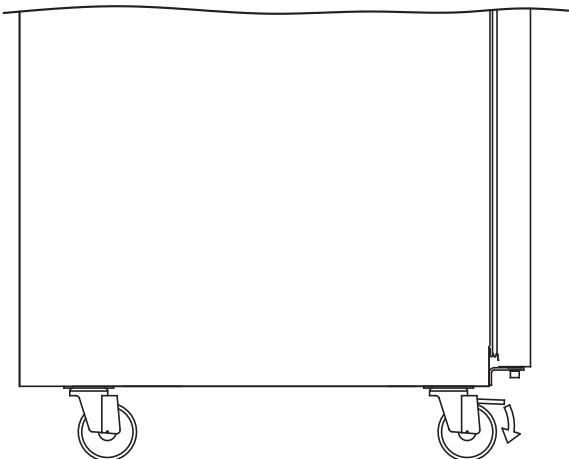

Reversal of door

Item numbers for door hinges

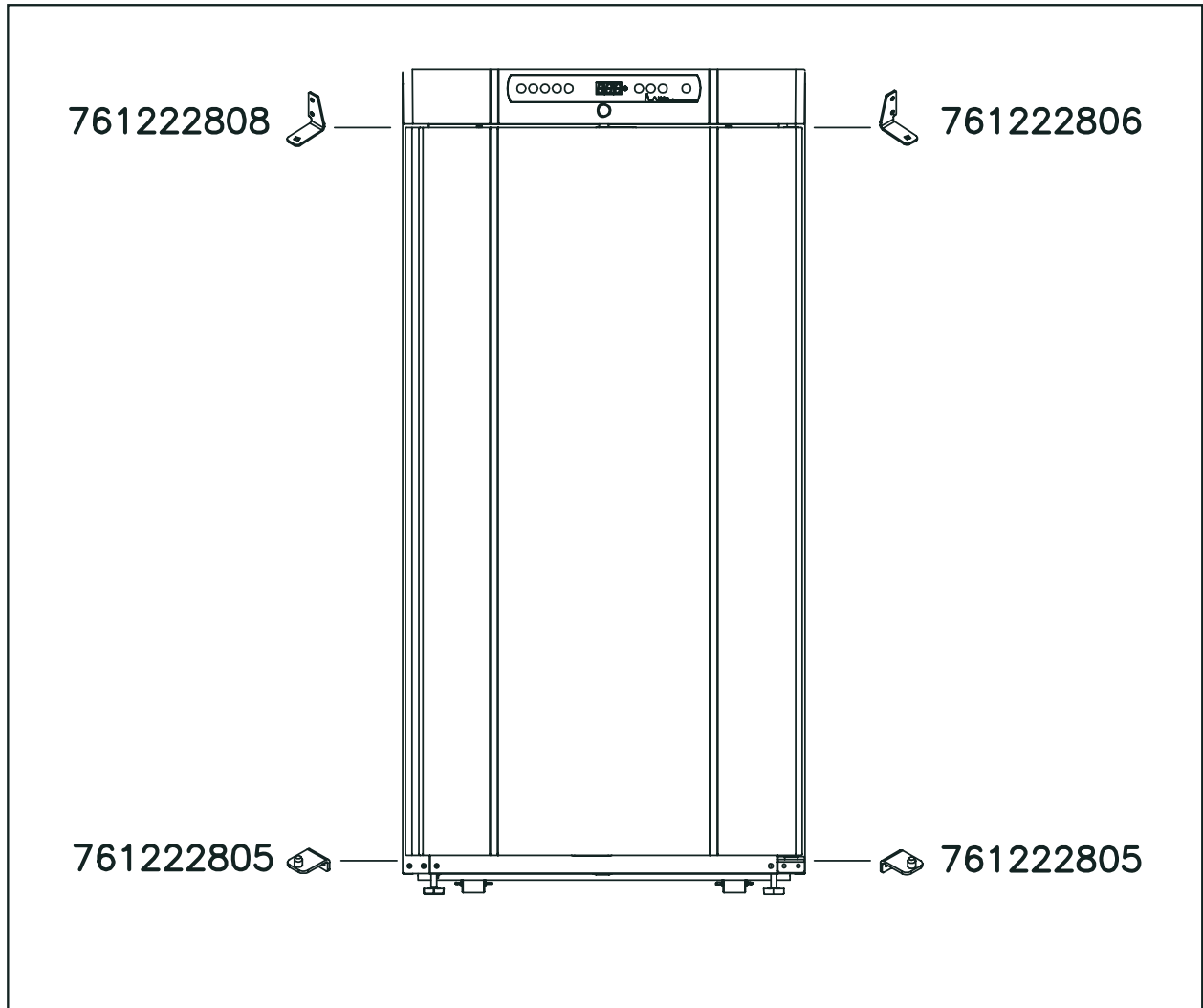

For replacement of brackets, please contact your local Gram BioLine distributor.

The cabinet must not be connected to a power source while changing door hinging.

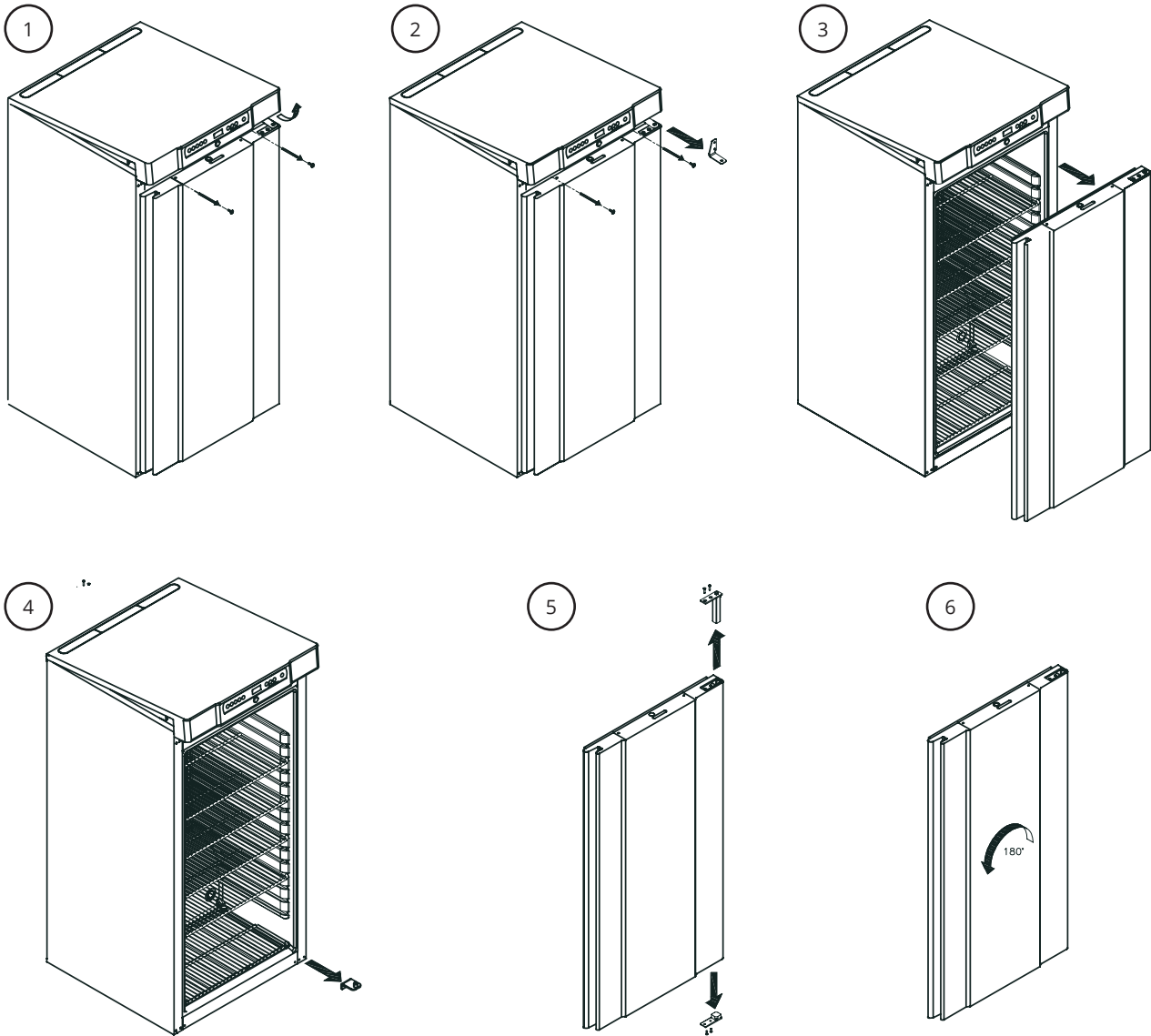

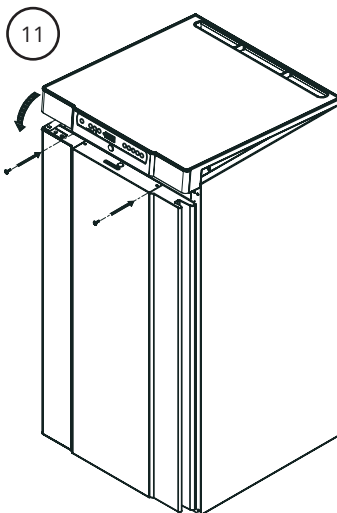
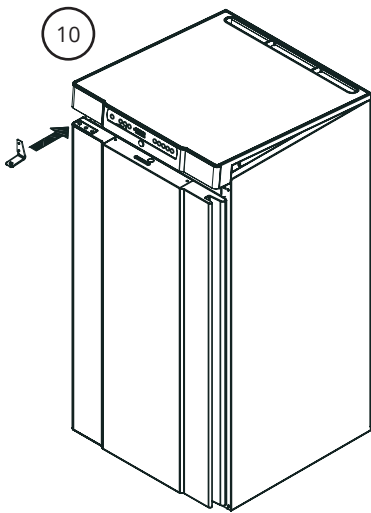
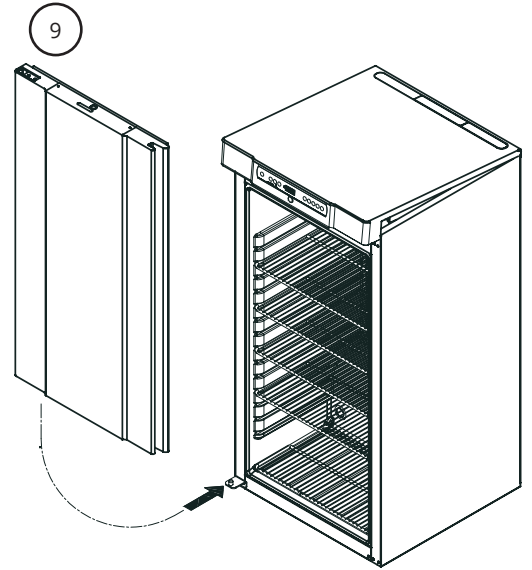
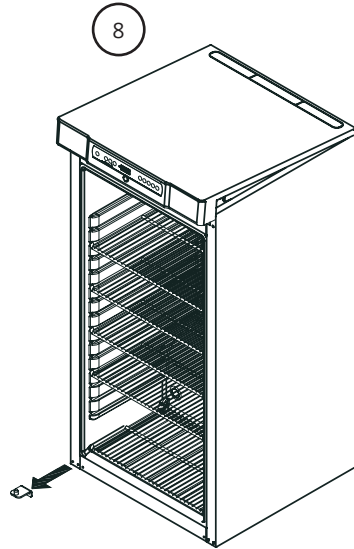
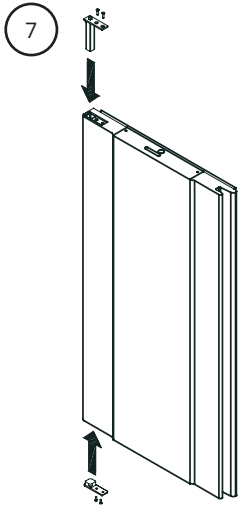

Anti tilt bracket

This part of the instructions for use describes how to secure the cabinet



I-12*: Cabinets with drawers and/or a glass door must be secured to a stable vertical surface, ensuring that the cabinet cannot tip over when the drawers are drawn to the outermost position, or the door is open. Brackets for securing is included. Find the instructions for the anti tilt below.

The anti tilt brackets must be fitted when installing the cabinet, ensuring that the users, the surroundings and stored items are not damaged by a tilting cabinet.

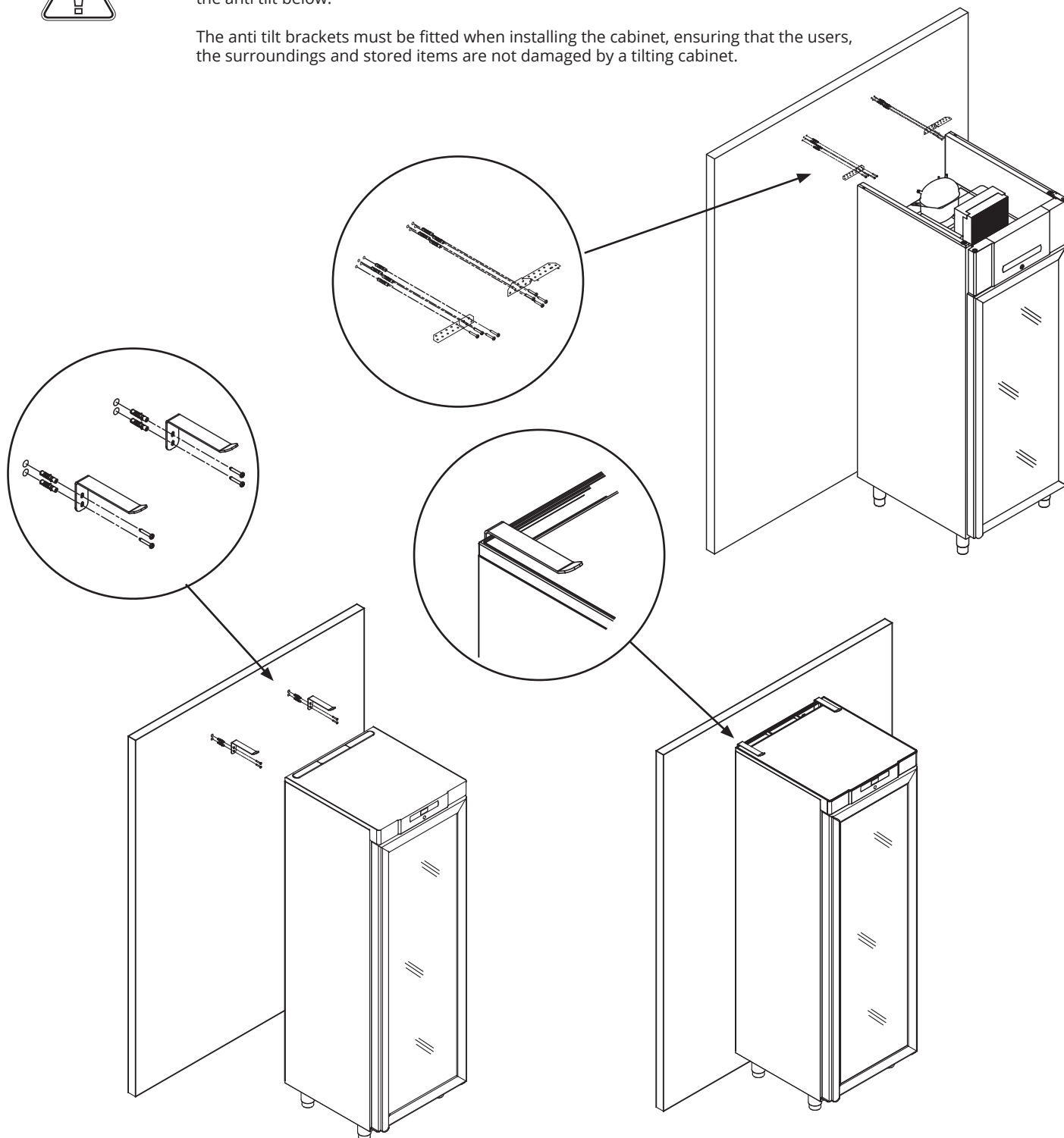

Wall mounting

This part of the instructions for use describes how to mount the cabinet on to a wall



Find instructions on wall mounting of a BioCompact II 210 below.
The same procedure applies for mounting 310, 210/210, 310/210 and 410.

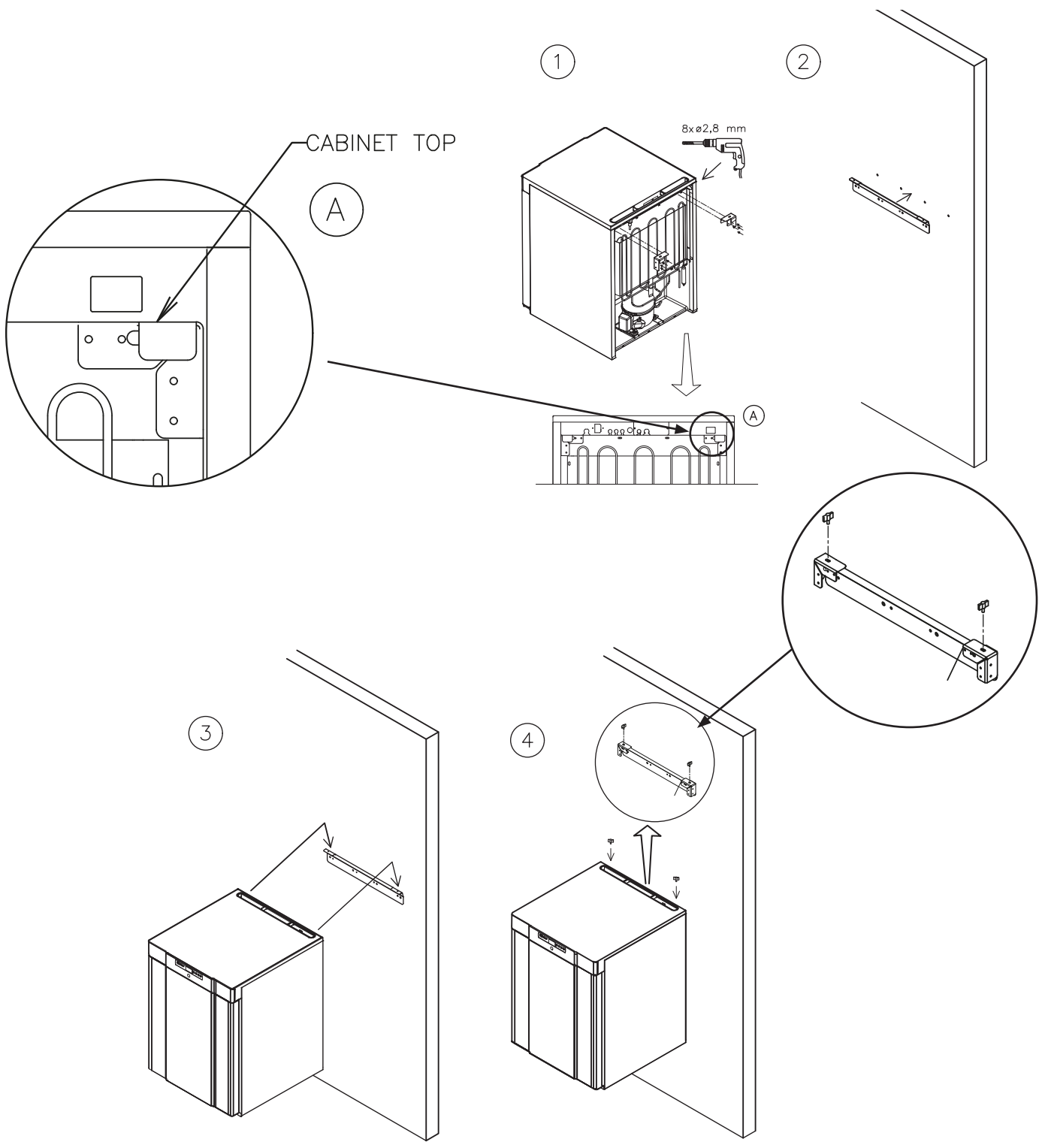

Surroundings

This part of the instructions for use describes how to install the cabinet



I-13-14*: The cabinet must be installed in accordance with the illustrations below.

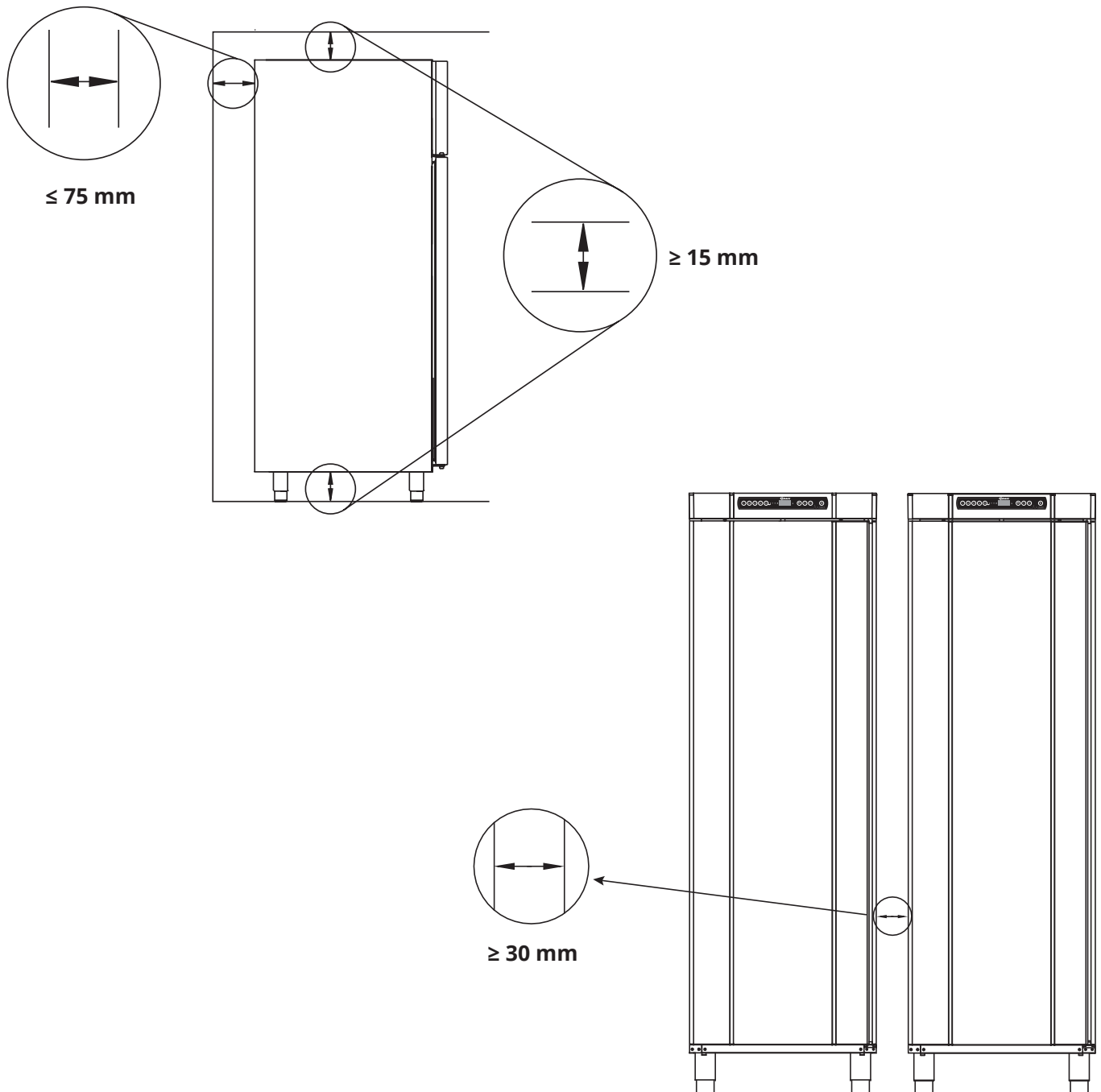



I-15*: Do not cover the upper part of the cabinet.



I-16*: Do not use electrical appliances inside the cabinet.



The cabinet is not suited for storing items that emit vapours, as this might lead to deterioration of the cabinet's performance and/or longevity.



All items in the cabinet that are not encapsulated, or wrapped, should be covered to reduce the risk of deterioration of the cabinet's performance and/or longevity.

- ATTENTION -

A visual inspection of the cabinet must be conducted prior to putting the cabinet into service.



Check the cabinet's structural integrity, that the door frame and door do not have deformities, that the gasket seals properly and that the door sits flush up against the door frame.

- For Ex environments -



Open containers inside the storage chamber may impact the ATEX zone classification.

- For Ex environments -



Special conditions for safe use may apply to this product when installing in an EN 60079-14 environment. Please see corresponding Ex certificate for specifications.

Voltage-free contact

This part of the instructions for use covers the voltage-free contact.

I-17*: The illustration shows the three connectors for the relay (used ex. in connecting to CTS or other external monitoring systems). The three connections, are respectively. Common, NO and NC.

The moment when voltage is applied the controller draws the relay, this makes it possible for the controller to respond to both high and low alarms, door alarms and power failures. Temperature alarms and door alarms must be configured in the external alarm settings (EAL) before they will activate the voltage-free contact. Find instructions on setting the external alarms in the parameter settings section.

Access to the voltage-free contact is done according to the descriptions below:

BioCompact II 210, 310, 210/210, 310/210, 410

Unscrew the preload cover on the back of the cabinet to access the voltage-free contact block.

Two different sized strain reliefs are mounted into the preload cover for a secure fitment of the wire for the voltage-free contact.

Ensure that the preload cover is reinstalled after installing the voltage-free contact.
The leaf spring in the preload cover must engage and preload the power supply plug.

Consult the section "Connection to power" for further information.

BioCompact II 610

The voltage-free contact is secured in place by the press-fit plate that is pressed onto the block, thereby also preventing access to the electrical circuit.

Connection of the voltage-free contact should be done by a qualified installer.

Placement of voltage-free contact.

BioCompact II 610

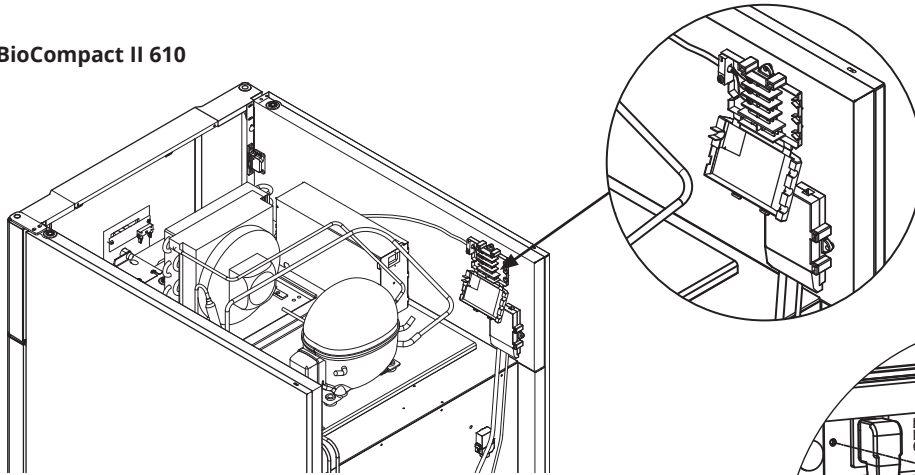

BioCompact II 210, 310, 210/210, 310/210, 410

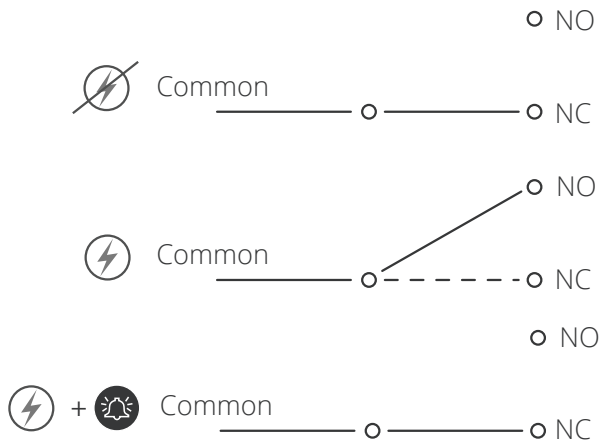
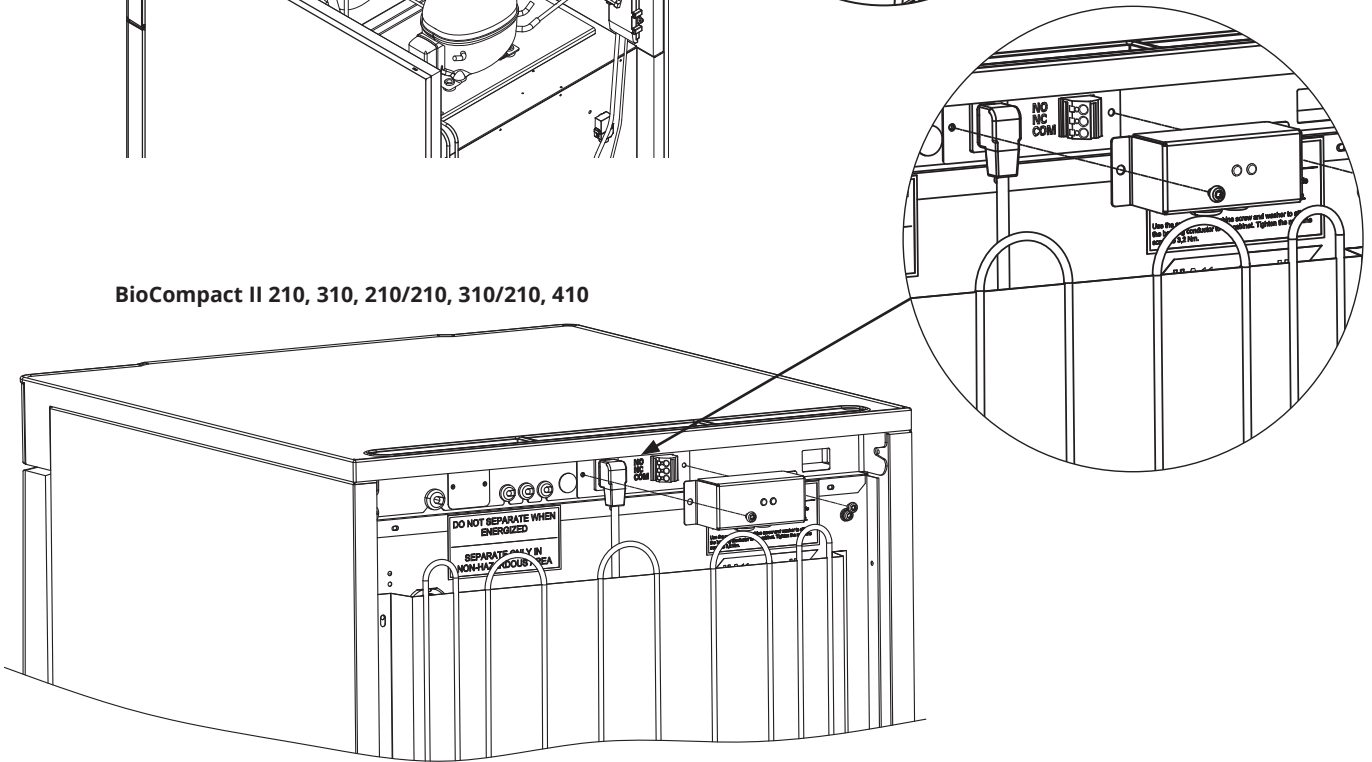

Normally closed circuit (NC)

Connection to power

Read the following part thoroughly before connecting the cabinet. Contact a qualified electrician if in doubt.

When setting up in an ordinary scenario that is not subject to regulations for EN 60079-15 zone 2:

The appliance may be connected in accordance with applicable local heavy current regulations.

Note that there are special regulations for products that are in accordance with EN 60079-15 zone 2 and EN 60079-14: Explosive atmospheres – Electrical installations design, selection and erection.

The appliance has been manufactured in accordance with EN 60079-15: Electrical apparatus for explosive gas atmospheres – Part 15: Type of protection II 3G Ex ec nC ic IIB Tx Gc. Zone 2 is the applicable zone. If the appliance is to be installed in a zone 2 environment, specialist personnel should perform the installation, or be consulted beforehand, in order to ensure that the appliance is installed in compliance with the guidelines currently contained in the standard.

I-19*: The cabinet is intended for connection to alternating current. The connection values for voltage (V) and frequency (Hz) are given on the type/number plate.

I-20-1*: BioCompact II 210, 310, 210/210, 310/210, 410

The mains terminal is accessed via the preload cover on the back of the cabinet. Unscrew the preload cover to access the mains supply terminal. Ensure that the preload cover is reinstalled after plugging in the power cord. The leaf spring in the preload cover must engage and preload the plug of the cord as shown in the illustrations below.

I-20-2*: BioCompact II 610

The power cord is plugged in the terminal box as shown. The plug is then fixated in place by the hanger that is built into the terminal box.

Please note: The hanger should be fitted tightly around the plug. In all cases, ensure that the mains plug is seated completely in the terminal on the cabinet.

The appliance must be connected to the external power supply using a suitable device which mechanically prevents the plug and socket from being separated unintentionally.

I-21*: The connection must be labelled: **"DO NOT SEPARATE WHEN ENERGIZED"**.

– ATTENTION –

Fuses and similar must never be removed or replaced while the appliance is connected to a power source. The electrical terminal box must never be opened while the appliance is connected to a power source.

The compressor's starting equipment must never be dismantled while the appliance is connected to a power source.

Whenever electrical components are dismantled or replaced, the appliance must be moved to an area in which there is no risk of ignition caused by the electrical components or gases contained in the appliance.

Never use the cabinet if the plug is damaged. The cabinet should be examined by a Gram BioLine service technician in such cases.

When setting up in an ordinary scenario that is not subject to regulations for Zone 2: The appliance may be connected in accordance with applicable local heavy current regulations.

In both cases

Use a three-wire plug, if the power outlet is intended for a three-wire plug, the lead in green/yellow insulation should be connected to the ground terminal. Power must be connected via a wall socket. The wall socket should be easily accessible.

All earthing requirements stipulated by the local electricity authorities must be observed. The cabinet plug and wall socket should then have correct earthing. If in doubt, contact your local supplier or authorised electrician.

– For Ex environments –



Special conditions for safe use may apply to this product when installing in an EN 60079-14 environment. Please see corresponding Ex certificate for specifications.

– Technical Support –

In the event of technical difficulties always contact Gram BioLine technical support or a Gram BioLine authorised service partner. Never dismantle the terminal box or any other electrical component.

**Connection to power -
BioCompact II 210, 310, 210/210, 310/210, 410**

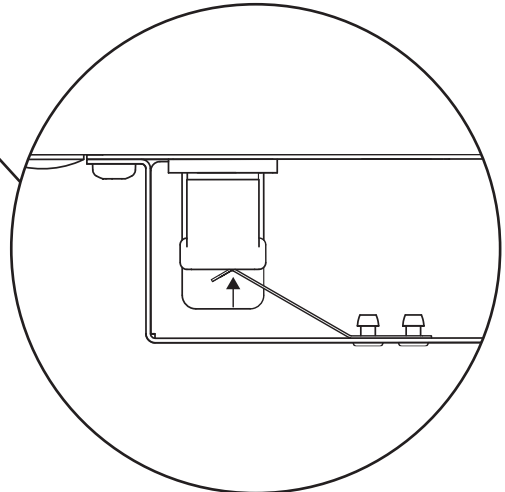
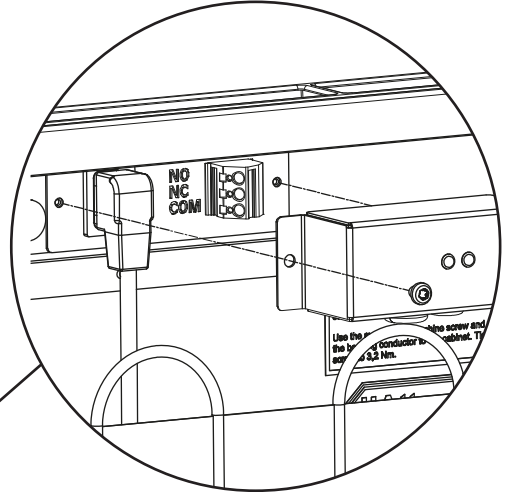
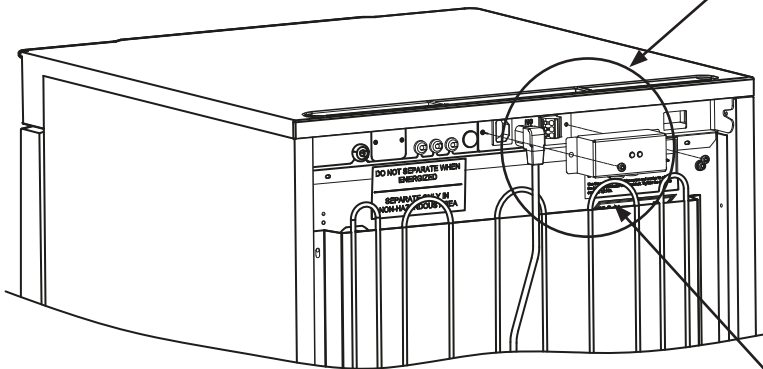

Connection to power - BioCompact II 610

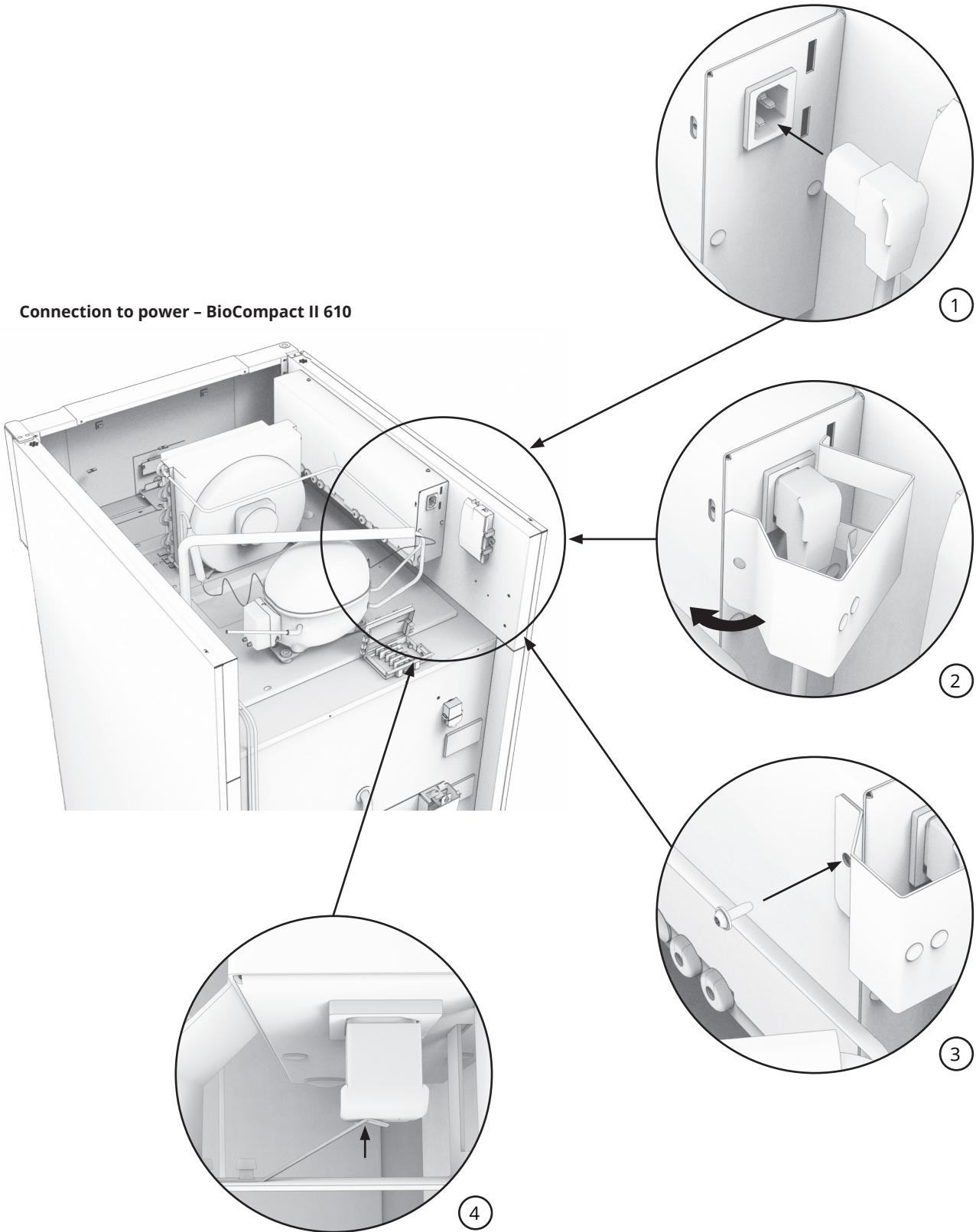

Equipotential bonding

Exclusively for the models: BioCompact II 210, 310, 410, 210/210, 310/210



I-22-1*: For installation in ATEX Cat. 3 Zone 2 areas, it is mandatory to have a equipotential bonding, it is not sufficient to use protective earth through the mains connection.

To secure equipotential bonding of the unit – the mounted external bonding conductor must be used in accordance with national installation requirements e.g. EN 60079-14.

- Mounting of the bonding conductor should be done according to the following illustrations.
- Please find the location for the connection facilities on the back of the cabinet marked with: "Attention – Equipotential bonding".
- The bonding conductor should be at least 4 mm² guage thickness.
- Use a ring terminal to ensure adequate bonding.
- Use the supplied M5 machine screw and washer to attach the bonding conductor to the cabinet. Tighten the machine screw to 3.2 Nm.

Bonding of the cabinet is illustrated on the next page.

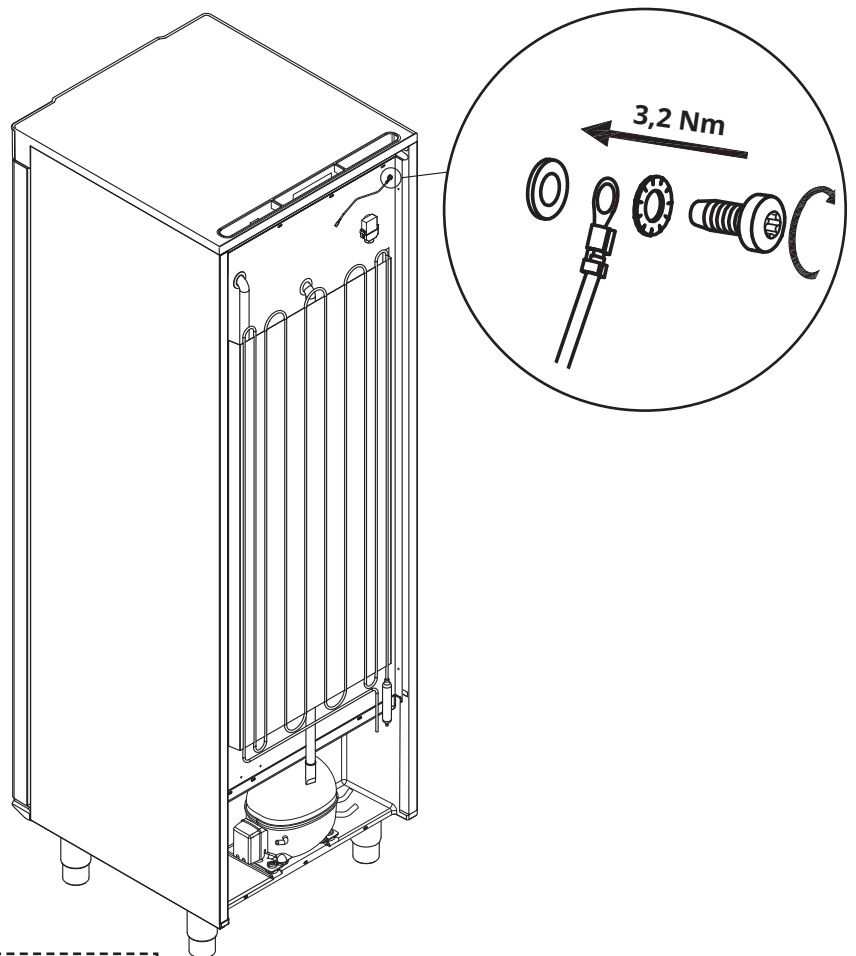

- ATTENTION -

This location is the only manufacturerer-approved location for equipotential bonding.

Options assembly

Introduction

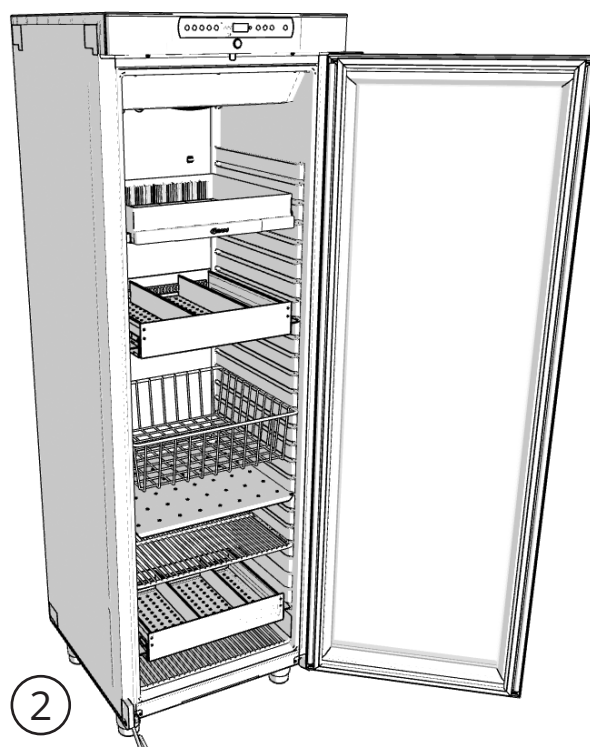
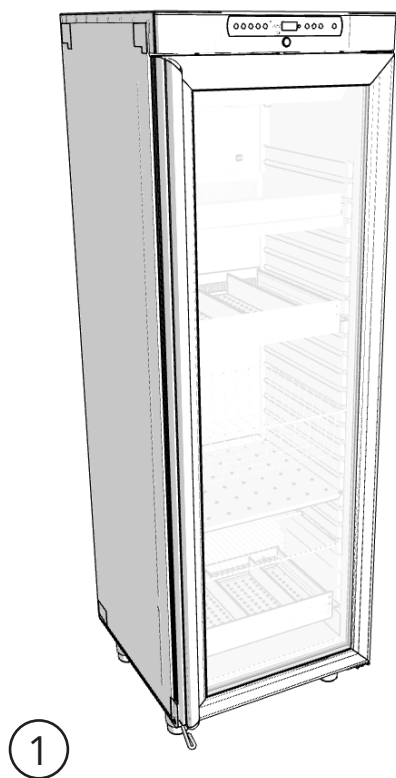

ABS drawer

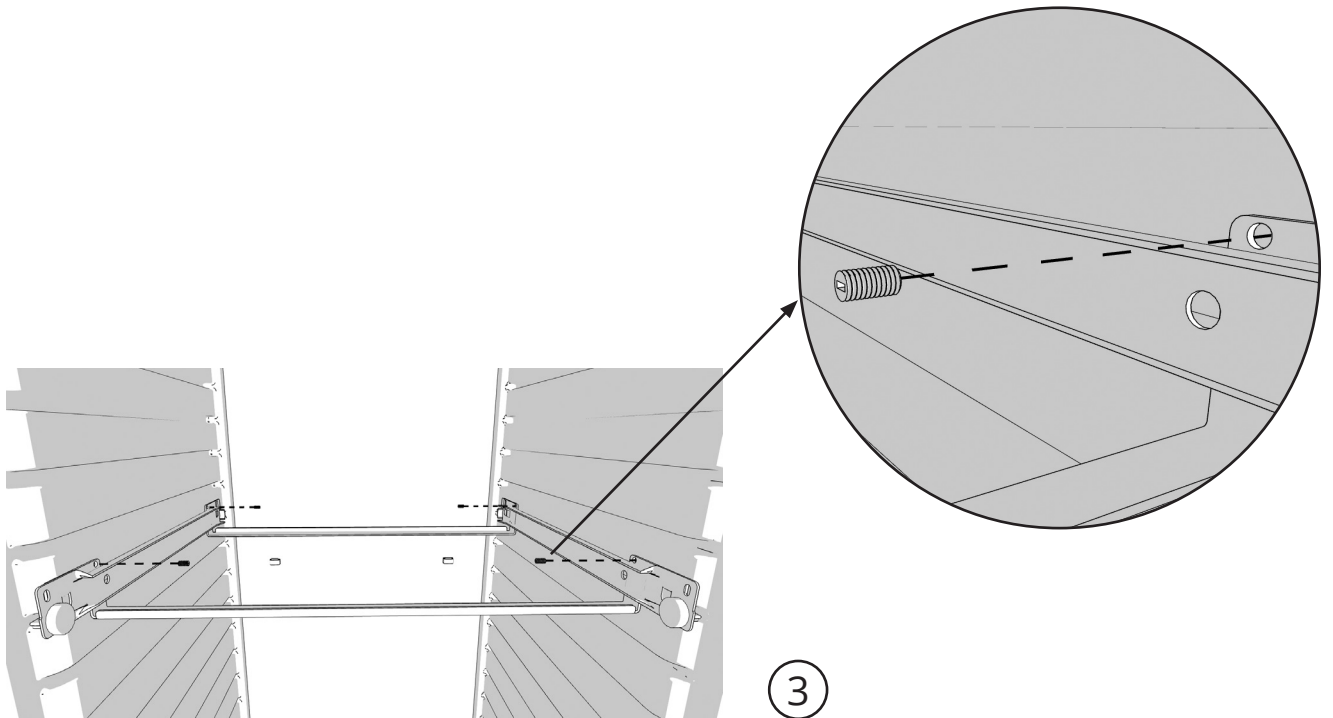
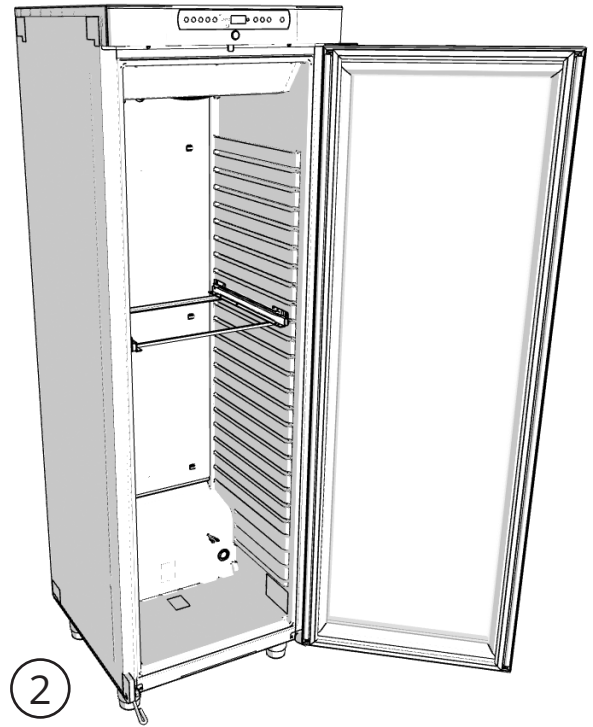
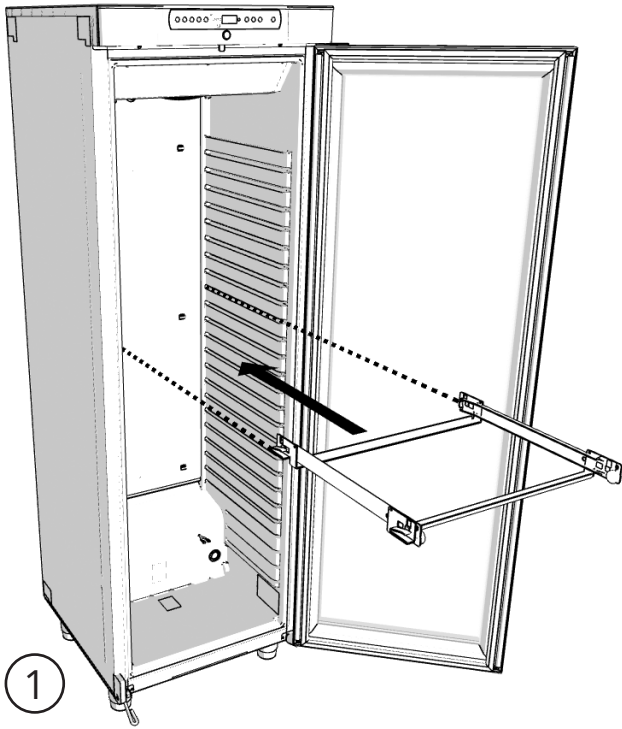

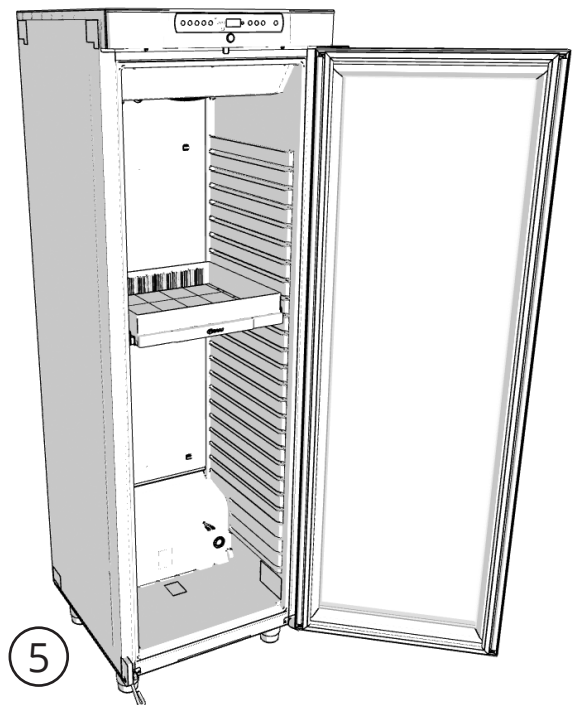
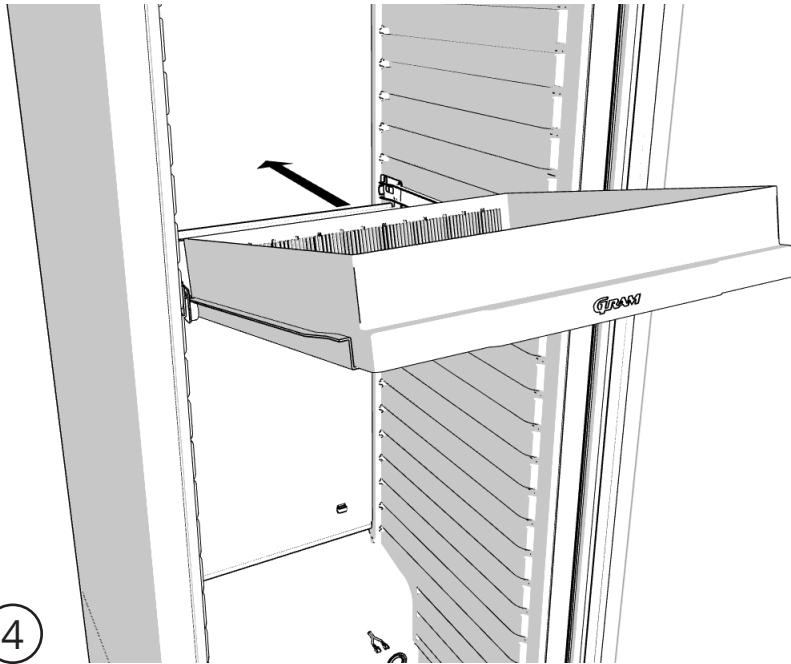

Aluminium drawer

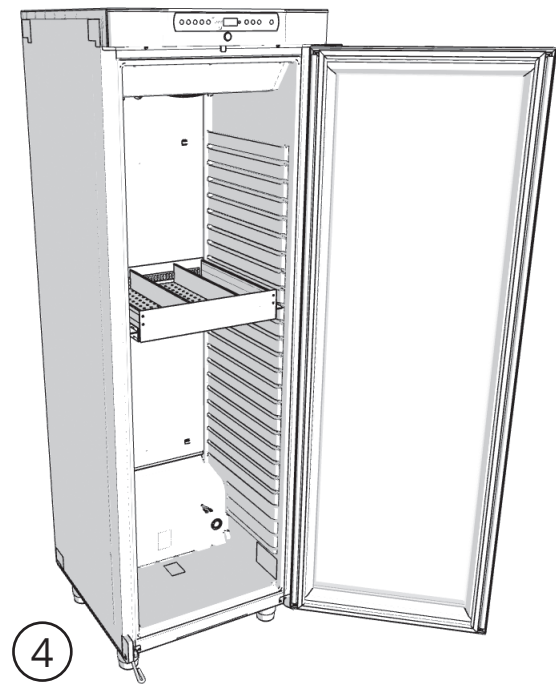
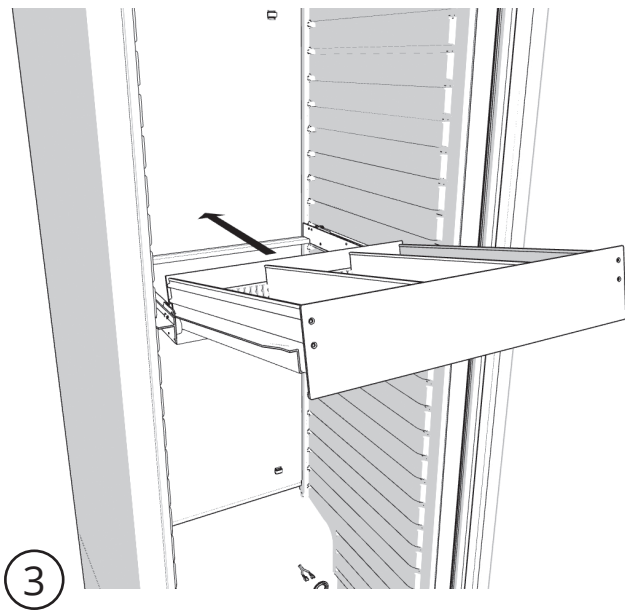
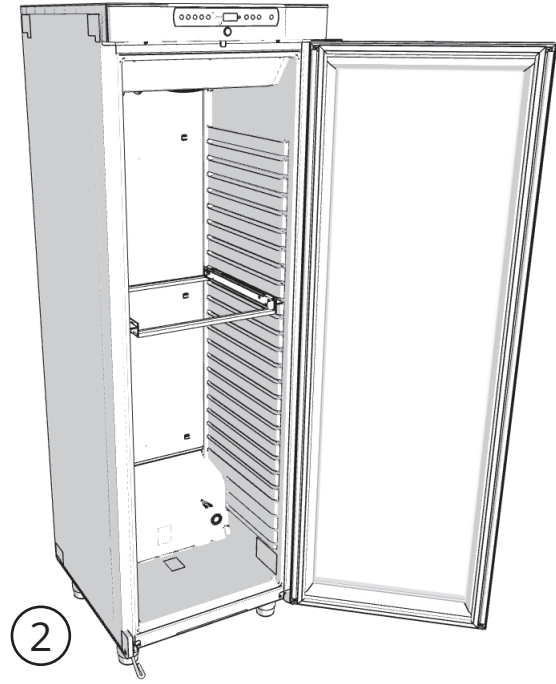
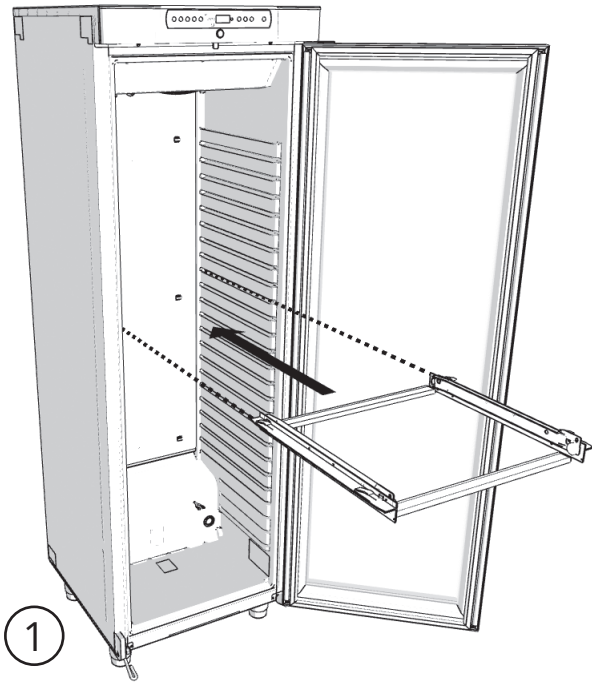

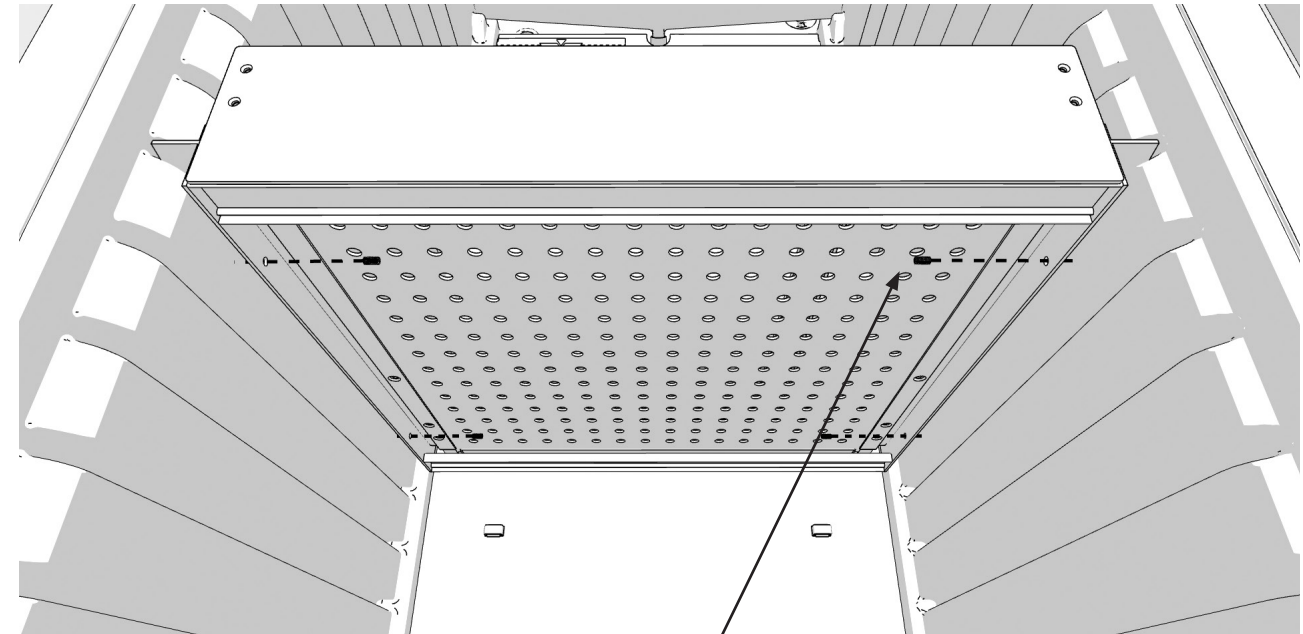

5

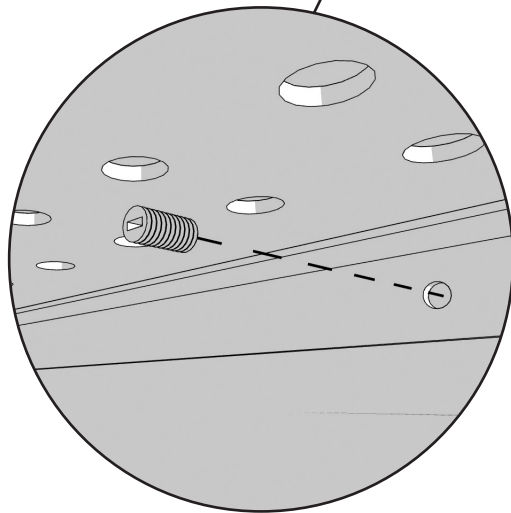

Wire basket

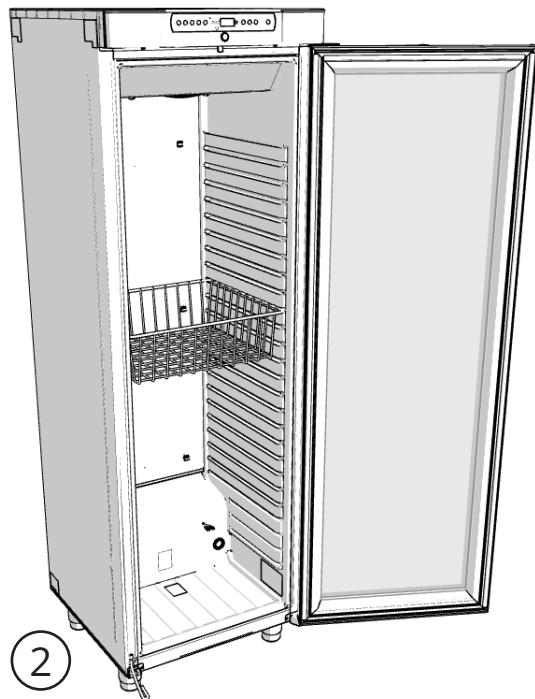
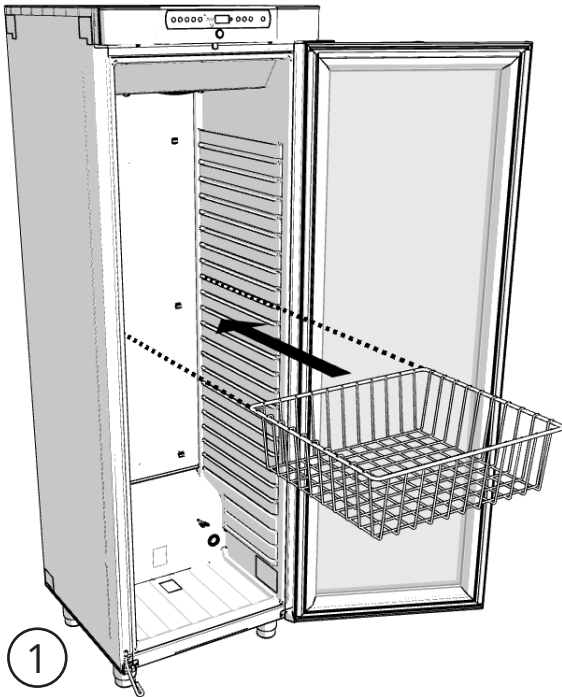

Wire basket 300 mm

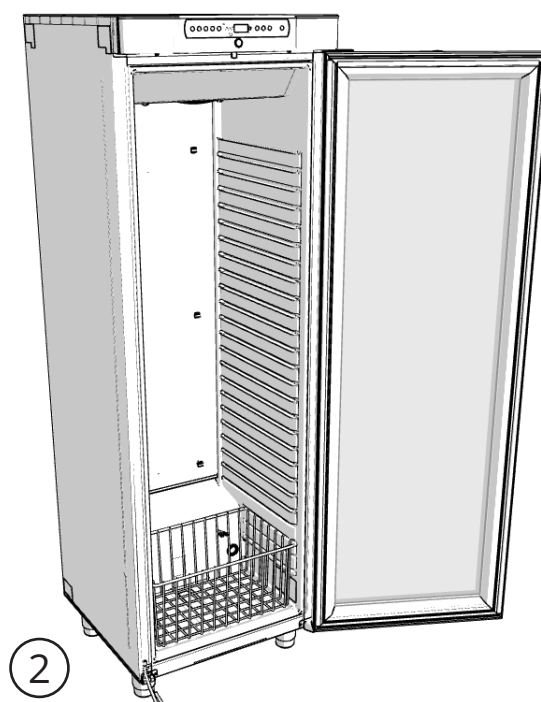
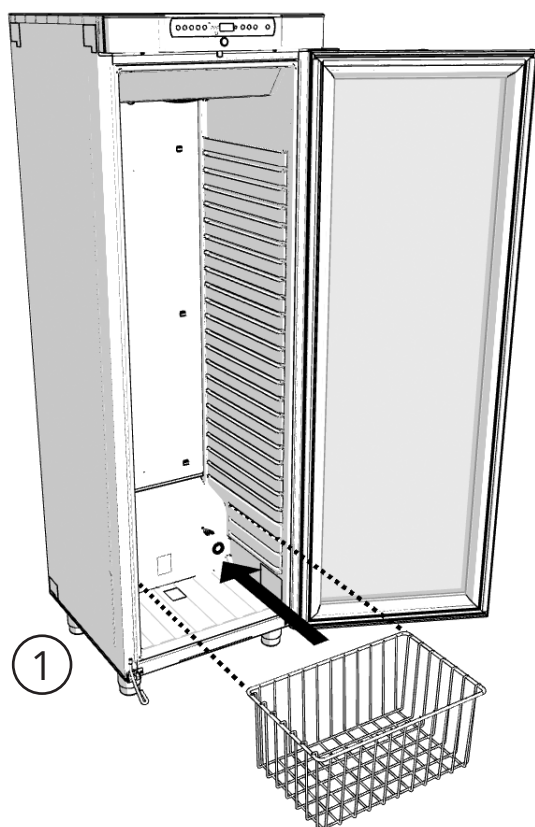

Wire shelf

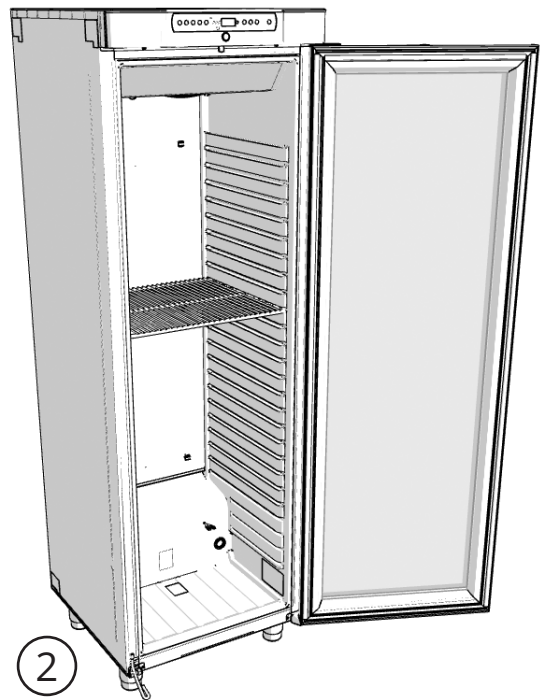
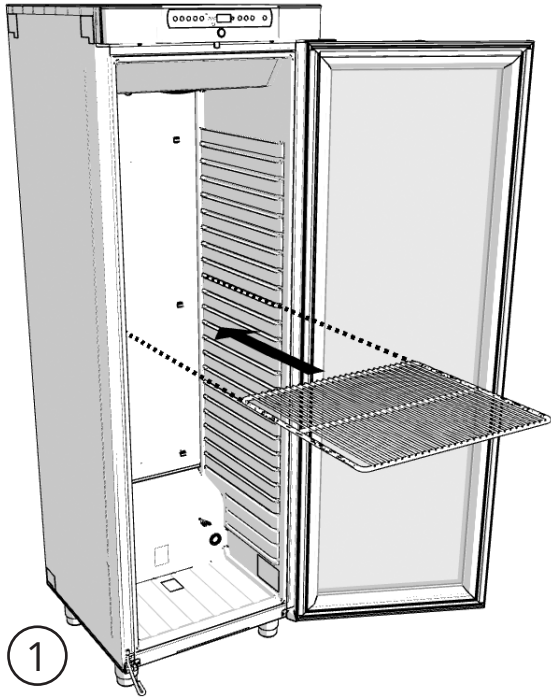

Wire shelf 300 mm

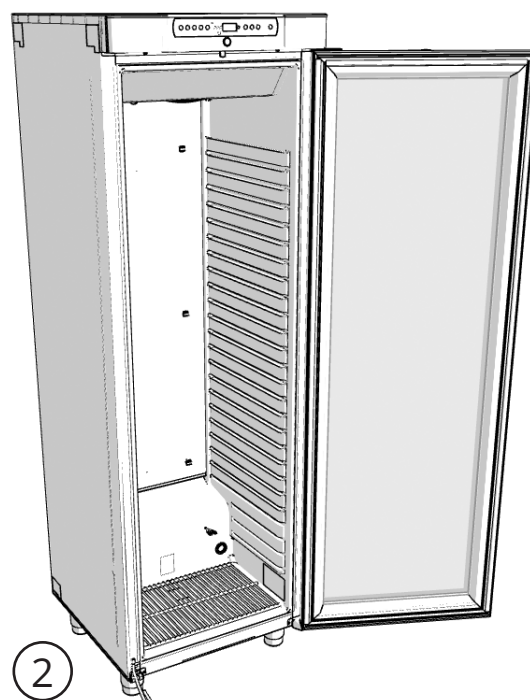
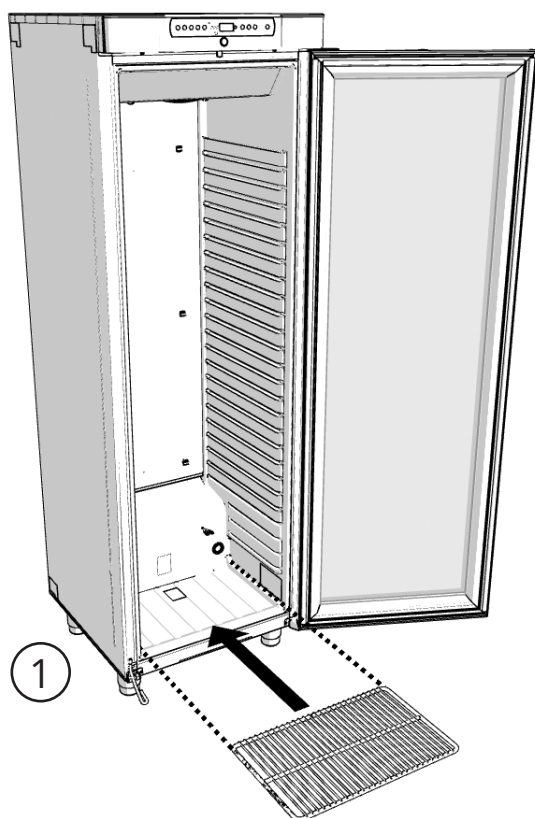

Perforated shelf

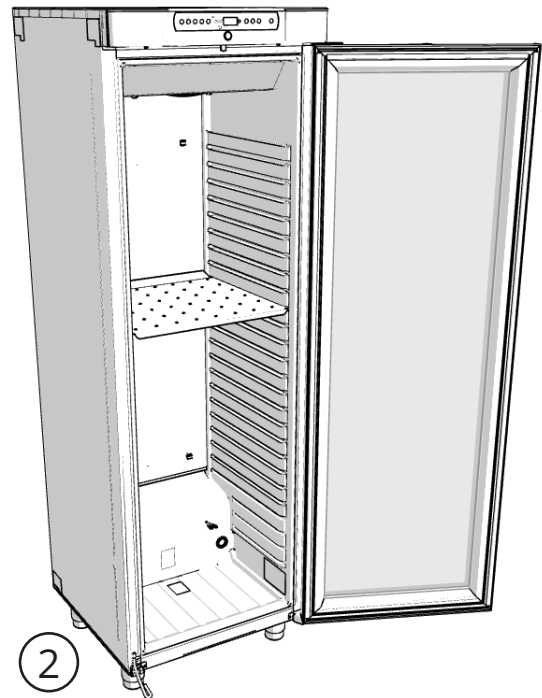
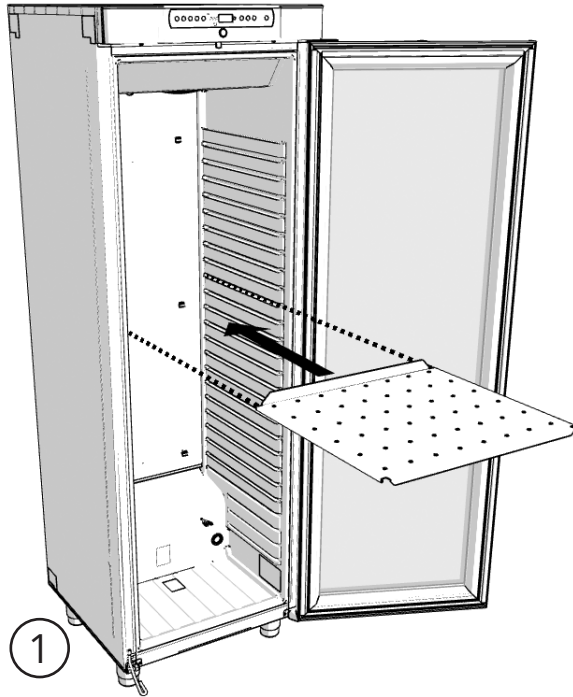

Start-up

The digital display

The digital display depicted below, shows the cabinet's temperature and indicates if the cabinet is connected to a power source.

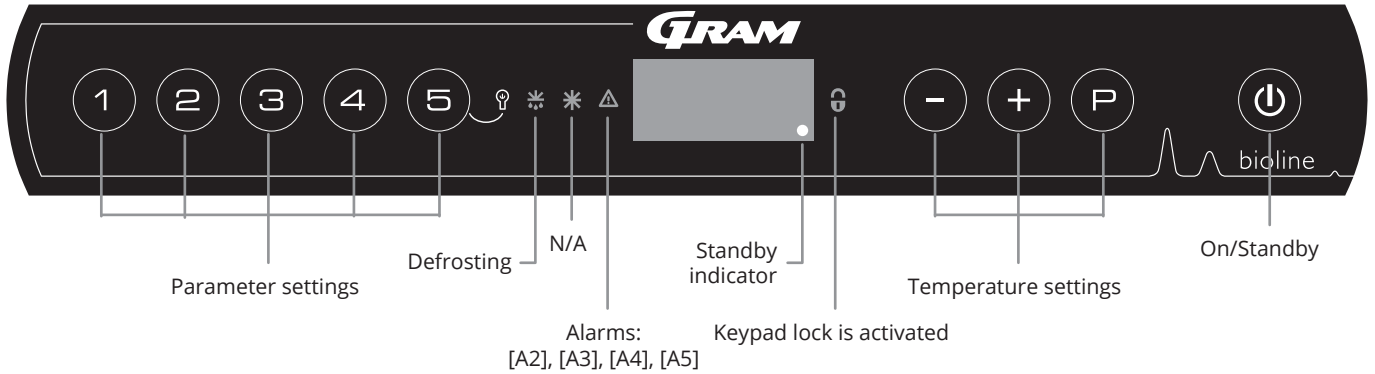

O-1*: On/Standby

Press the key to turn the cabinet on. Press the key for 6 seconds to switch to standby. The software version of the cabinet will be shown when turning the cabinet on, followed by the software variant. The cabinet is ready when the temperature is displayed.

The cabinet will automatically start a defrost-cycle when turned on, and terminate it again after a system check.

- ATTENTION -

Make sure the cabinet is switched off at the socket before service is performed on electrical parts.



It is not sufficient to switch the cabinet to standby on the key, as current will persist in some electrical parts of the cabinet.

If fuses or similar are to be replaced, the cabinet must be moved to a no-risk area.

- WARNING -

DO NOT OPEN, MAINTAIN OR SERVICE IN AN AREA WHEN AN EXPLOSIVE ATMOSPHERE IS PRESENT.



- ATTENTION -

High and low-temperature alarms set up in the cabinet's controller (including EAL alarms) must be accompanied by additional redundant independent external alarms to ensure maximum item safety.



• Parameter setting

Gives access to the cabinet's configurable parameters, such as alarms, test programs and sensor values.

• Defrost

Defrost in progress.

• Keypad lock

Keypad is locked, no access to functions or menus.

• Temperature setting

Setting of the temperature setpoint and navigation in the menus.

• On/Standby

Turn the cabinet on or switch to standby, and navigation in the menus.

O-2*: Temperature setting

Temperature adjustments are done by holding and pressing either or . Confirm the settings by letting go of the keys.

All-round introduction to navigating the menus

Beyond setting the temperature and standby, , , and is used to navigate the menus and set the parameters for the cabinet.

The keys have the following functions in the menus:

- Open a menu step or confirm a set value in the parameter settings.
- Scroll upwards in a given menu or raise a given value in parameter settings (alarm limit for instance).
- Scroll downwards in a given menu or lower a given value in parameter settings (alarm limit for instance).
- Go back a step in the menus.

Walkthrough of menu

The menu below gives a quick overview of the parameter settings for the cabinet.

Menu access $\text{P} + \text{1} \rightarrow$	↓	→		
Local alarm settings	LAL	LhL	[° C]	Upper alarm limit. Code for activated alarm [A2]
		LLL	[° C]	Lower alarm limit. Code for activated alarm [A3]
		Lhd	[min.]	Delay of upper alarm limit
		LLd	[min.]	Delay of lower alarm limit
		dA	On/off	Door alarm. Code for activated alarm [A1]. [1=on/0=off]
		dAd	[min.]	Delay of door alarm
		BU	On/off	Acoustic signal for alarm codes [A1], [A2] and [A3]. [1=on/0=off]
External alarm settings	EAL	EhL	[° C]	Upper alarm limit. Code for activated alarm [A4]
		ELL	[° C]	Lower alarm limit. Code for activated alarm [A5]
		Ehd	[min.]	Delay of upper alarm limit
		ELd	[min.]	Delay of lower alarm limit
		dA	On/off	Door alarm. Code for activated alarm [A1]. [1=on/0=off]
		dAd	[min.]	Delay of external door alarm
		BU	On/off	Acoustic signal for external alarm codes [A1], [A4], [A5]. [1=on/0=off]
Offset of sensors	CAL	cA	[° K]	Offset setting of A-sensor. Reference sensor for the refrigeration system
		cE	[° K]	Offset setting of E-sensor. Reference sensor for the display and alarms
		cF	[° K]	Offset setting of F-sensor. Reference sensor for the low-temperature protection
Electric low-temperature protection	FP	Act	On/off	Activation/deactivation of low-temperature protection
		tES	On	Test of low-temperature protection
		SEt	[° C]	Setting of the cut-off temperature for the low-temperature protection
		PrE	[...]	Read-out of the real-time temperature of the F-sensor
	ALL			Activation of escorted alarm limits. [FAS]=locked limits/[ESC]=follows setpoint
	dEF			Number of defrosts per 24 hours (4 is factory setting)
	dPS			Reference sensor for the display (A, E or F)

Keys	Duration	Function
$\text{P} + \text{⏻}$	> 3 seconds	Start or stop a defrost
$\text{⏻} + \text{1}$	> 6 seconds	Activating/deactivating the keypad lock
P	-	Shows the temperature setpoint value
+	-	Shows the highest registered temperature spike (since the last reset of the alarm history)
-	-	Shows the lowest registered temperature spike (since the last reset of the alarm history)
$\text{+} + \text{-}$	> 3 seconds	Reset of the alarm history
$\text{P} + \text{1} + \text{3}$	> 6 seconds	Restore to the factory settings
$\text{P} + \text{1}$	> 3 seconds	Access to the user menu and alarm settings

Lighting inside the cabinet (only applicable to BioCompact II cabinets with glass doors)

The settings for the lighting inside the cabinet can be changed by pressing and holding ⏻ for 3 seconds.

There are two settings:

- 1) Light turns on when the door is open (off when closed)
- 2) Light is always on



Error codes

The following table covers the different error codes that can occur.

Display code	Explanation
- 0 -	Door is open. Open door indicator. Alarm [A1] will activate if the door is open longer than alarm limits
[A1]	Door alarm "dAd" from LAL and/or EAL has been activated
[A2]	Local upper alarm LhL is or has been activated
[A3]	Local lower alarm LLL is or has been activated
[A4]	External upper alarm EhL is or has been activated
[A5]	External lower alarm ELl is or has been activated
F1	Error on sensor for refrigeration system
F2	Error on evaporator sensor
F3	Error on condensor sensor
F5	Error on sensor for display and alarms
F6	Error on sensor for low-temperature protection
F7	F7 indicates that the temperature of the condensor is too high. Turn off the cabinet and check that the condenser is not covered, and ensure that the condenser (and possibly filter) is clean. Service is required if the problem is not alleviated

Acknowledge an acoustic alarm

Alarm code [A1]: Press  to acknowledge.

Temperature alarm codes [A2] and/or [A3]: Flashes in the display. Press  to acknowledge.

The display will continue to flash if the temperature is outside the alarm limits.



Latching alarms: [A2], [A3], [A4], [A5]





Due to the potential implications of alarms, the red alarm triangle icon will turn on along with the corresponding alarm code will flash in the display. The alarm state will remain on until acknowledged by pressing .

Reading the alarm history - Example [A2]

[A2] flashes in the display - The temperature has exceeded the set value for the upper temperature limit, LhL.

Press  to acknowledge the [A2]. The display continues to flash, indicating that there is information in the alarm history.



Press , "Htt" (High temperature time) is shown, press  to see for how long the temperature was above the set alarm limit.

Press  to return to "Htt". Press  to reach "Ht" (Highest temperature). Press  to read the highest recorded temperature during Htt. Press  to return to "Ht" and press  again to leave the alarm history.

The procedure for reading an [A3] alarm is identical, apart from entering the alarm history with . When reading out temperatures below set limits, the parameters are Ltt and Lt.

A flashing display with no alarm codes indicates that the alarm codes have been acknowledged, but the alarm history contains information.

Resetting the alarm temperature and the alarm history

Resetting of the max./min. and the alarm history is done by holding  and  for more than 3 seconds, an acoustic signal will be given when reset is complete.

Local high alarm Local low alarm

O-3*: LhL – Setting the upper alarm limit [° C]

- ↳ Press and hold (P) + (1) for more than 3 seconds
- ↳ Press (P) to select “LAL”. “LhL” is now shown in the display
- ↳ Press (P) to select “LhL”. The upper alarm limit is now shown in the display
- ↳ Press (–) or (+) to set the desired value for the upper alarm limit
- ↳ Press (P) to confirm the set value
 - The upper alarm limit is now set, proceed to other parameters by pressing (⏪), then navigate by using (–) or (+)
- ↳ Leave the user menu by pressing (⏪) several times until the cabinet’s temperature is shown in the display

O-4*: LLL – Setting the lower alarm limit [° C]

- ↳ Press and hold (P) + (1) for more than 3 seconds
- ↳ Press (P) to select “LAL”. “LhL” is now shown in the display
- ↳ Press (+) to proceed to “LLL”
- ↳ Press (P) to select “LLL”. The lower alarm limit is now shown in the display
- ↳ Press (–) or (+) to set the desired value for the lower alarm limit
- ↳ Press (P) to confirm the set value
 - The lower alarm limit is now set, proceed to other parameters by pressing (⏪), then navigate by using (–) or (+)
- ↳ Leave the user menu by pressing (⏪) several times until the cabinet’s temperature is shown in the display



– ATTENTION –

High and low-temperature alarms set up in the cabinet’s controller (including EAL alarms) must be accompanied by additional redundant independent external alarms to ensure maximum item safety.

Local high alarm delay

Local low alarm delay

O-5*: Lhd – Setting the delay of the local upper alarm limit [min.]

- ↳ Press and hold (P) + (1) for more than 3 seconds
- ↳ Press (P) to select "LAL". "LhL" is now shown in the display
- ↳ Press (+) several times until "Lhd" is shown in the display
- ↳ Press (P) to select "Lhd". The delay of the upper alarm limit is now shown in the display
- ↳ Press (-) or (+) to set the desired value for the delay of the upper alarm limit
- ↳ Press (P) to confirm the set value
 - The delay of the upper alarm limit is now set, proceed to other parameters by pressing (⏏), then navigate by using (-) or (+)
- ↳ Leave the user menu by pressing (⏏) several times until the cabinet's temperature is shown in the display

O-6*: LLd – Setting the delay of the local lower alarm limit [min.]

- ↳ Press and hold (P) + (1) for more than 3 seconds
- ↳ Press (P) to select "LAL". "LhL" is now shown in the display
- ↳ Press (+) several times until "LLd" is shown in the display
- ↳ Press (P) to select "LLd". The delay of the lower alarm limit is now shown in the display
- ↳ Press (-) or (+) to set the desired value for the delay of the lower alarm limit
- ↳ Press (P) to confirm the set value
 - The delay of the lower alarm limit is now set, proceed to other parameters by pressing (⏏), then navigate by using (-) or (+)
- ↳ Leave the user menu by pressing (⏏) several times until the cabinet's temperature is shown in the display



- ATTENTION -

High and low-temperature alarms set up in the cabinet's controller (including EAL alarms) must be accompanied by additional redundant independent external alarms to ensure maximum item safety.

Activate/deactivate of local door alarm

Delay for local door alarm

O-7*: dA – Activate/deactivate of local door alarm

- ↳ Press and hold (P) + (1) for more than 3 seconds
- ↳ Press (P) to select "LAL". "LhL" is now shown in the display
- ↳ Press (+) several times until "dA" is shown in the display
- ↳ Press (P) to select "dA".
- ↳ Press (-) or (+) to activate/deactivate the local door alarm [1=activated/0=deactivated]
- ↳ Press (P) to confirm the set value
 - The local door alarm is now configured, proceed to other parameters by pressing (⏏), then navigate by using (-) or (+)
- ↳ Leave the user menu by pressing (⏏) several times until the cabinet's temperature is shown in the display

O-8*: dAd – Setting the delay of the local door alarm [min.]

- ↳ Press and hold (P) + (1) for more than 3 seconds
- ↳ Press (P) to select "LAL". "LhL" is now shown in the display
- ↳ Press (+) several times until "dAd" is shown in the display
- ↳ Press (P) to select "dAd". The delay of the local door alarm is now shown in the display
- ↳ Press (-) or (+) to set the desired value for the delay of the local door alarm
- ↳ Press (P) to confirm the set value
 - The delay of the local door alarm is now configured, proceed to other parameters by pressing (⏏), then navigate by using (-) or (+)
- ↳ Leave the user menu by pressing (⏏) several times until the cabinet's temperature is shown in the display



- ATTENTION -

High and low-temperature alarms set up in the cabinet's controller (including EAL alarms) must be accompanied by additional redundant independent external alarms to ensure maximum item safety.

Local acoustic settings

O-9*: BU – Activation/deactivation of the acoustic local alarms

- ↳ Press and hold (P) + (1) for more than 3 seconds
- ↳ Press (P) to select "LAL". "LhL" is now shown in the display
- ↳ Press (+) several times until "BU" is shown in the display
- ↳ Press (P) to select "BU".
- ↳ Press (-) or (+) to activate/deactivate the local acoustic alarms [1=activated/0=deactivated]
- ↳ Press (P) to confirm the set value
 - The local acoustic alarms is configured, proceed to other parameters by pressing (⏻), then navigate by using (-) or (+)
- ↳ Leave the user menu by pressing (⏻) several times until the cabinet's temperature is shown in the display



- ATTENTION -

High and low-temperature alarms set up in the cabinets' controller (including EAL alarms) must be accompanied by additional redundant independent external alarms to ensure maximum item safety.

External high alarm External low alarm

O-10*: EhL – Setting the external upper alarm limit [° C]

- ↳ Press and hold (P) + (1) for more than 3 seconds
- ↳ Press (+) several times until "EAL" is shown in the display
- ↳ Press (P) to select "EAL". "EhL" is now shown in the display
- ↳ Press (P) to select "EhL". The external upper alarm limit is now shown in the display
- ↳ Press (-) or (+) to set the desired value for the external upper alarm limit
- ↳ Press (P) to confirm the set value
 - The external upper alarm limit is now set, proceed to other parameters by pressing (⏪), then navigate by using (-) or (+)
- ↳ Leave the user menu by pressing (⏩) several times until the cabinet's temperature is shown in the display

O-11*: ELL – Setting the external lower alarm limit [° C]

- ↳ Press and hold (P) + (1) for more than 3 seconds
- ↳ Press (+) several times until "EAL" is shown in the display
- ↳ Press (P) to select "EAL". "EhL" is now shown in the display
- ↳ Press (+) to proceed to "ELL"
- ↳ Press (P) to select "ELL". The external lower alarm limit is now shown in the display
- ↳ Press (-) or (+) to set the desired value for the external lower alarm limit
- ↳ Press (P) to confirm the set value
 - The external lower alarm limit is now set, proceed to other parameters by pressing (⏪), then navigate by using (-) or (+)
- ↳ Leave the user menu by pressing (⏩) several times until the cabinet's temperature is shown in the display



- ATTENTION -

High and low-temperature alarms set up in the cabinet's controller (including EAL alarms) must be accompanied by additional redundant independent external alarms to ensure maximum item safety.

External high alarm delay

External low alarm delay

O-12*: Ehd – Setting the delay of the external upper alarm limit [min.]

- ↳ Press and hold (P) + (1) for more than 3 seconds
- ↳ Press (+) to proceed to "EAL"
- ↳ Press (P) to select "EAL". "EhL" is now shown in the display
- ↳ Press (+) several times until "Ehd" is shown in the display
- ↳ Press (P) to select "Ehd". The external delay of the upper alarm limit is now shown in the display
- ↳ Press (-) or (+) to set the desired value for the external delay of the upper alarm limit
- ↳ Press (P) to confirm the set value
 - The delay of the external upper alarm limit is now set, proceed to other parameters by pressing (U), then navigate by using (-) or (+)
- ↳ Leave the user menu by pressing (U) several times until the cabinet's temperature is shown in the display

O-13*: ELd – Setting the delay of the external lower alarm limit [min.]

- ↳ Press and hold (P) + (1) for more than 3 seconds
- ↳ Press (+) to proceed to "EAL"
- ↳ Press (P) to select "EAL". "EhL" is now shown in the display
- ↳ Press (+) several times until "ELd" is shown in the display
- ↳ Press (P) to select "ELd". The delay of the external lower alarm limit is now shown in the display
- ↳ Press (-) or (+) to set the desired value for the delay of the lower alarm limit
- ↳ Press (P) to confirm the set value
 - The delay of the external lower alarm limit is now set, proceed to other parameters by pressing (U), then navigate by using (-) or (+)
- ↳ Leave the user menu by pressing (U) several times until the cabinet's temperature is shown in the display



- ATTENTION -

High and low-temperature alarms set up in the cabinet's controller (including EAL alarms) must be accompanied by additional redundant independent external alarms to ensure maximum item safety.

Activation/deactivation of external door alarm External door alarm delay alarm

O-14*: dA – Activation/deactivation of external door alarm

- ↳ Press and hold (P) + (1) for more than 3 seconds
- ↳ Press (+) to proceed to "EAL"
- ↳ Press (P) to select "EAL". "EhL" is now shown in the display
- ↳ Press (+) several times until "dA" is shown in the display
- ↳ Press (P) to select "dA"
- ↳ Press (-) or (+) to activate/deactivate the external door alarm [1=activated/0=deactivated]
- ↳ Press (P) to confirm the set value
 - The external door alarm is now configured, proceed to other parameters by pressing (⏻), then navigate by using (-) or (+)
- ↳ Leave the user menu by pressing (⏻) several times until the cabinet's temperature is shown in the display

O-15*: dAd – Setting the delay of the external door alarm [min.]

- ↳ Press and hold (P) + (1) for more than 3 seconds
- ↳ Press (+) to proceed to "EAL"
- ↳ Press (P) to select "EAL". "EhL" is now shown in the display
- ↳ Press (+) several times until "dAd" is shown in the display
- ↳ Press (P) to select "dAd". The delay of the external door alarm is now shown in the display
- ↳ Press (-) or (+) to set the desired value for the delay of the external door alarm
- ↳ Press (P) to confirm the set value
 - The delay of the external door alarm is now configured, proceed to other parameters by pressing (⏻), then navigate by using (-) or (+)
- ↳ Leave the user menu by pressing (⏻) several times until the cabinet's temperature is shown in the display



- ATTENTION -

High and low-temperature alarms set up in the cabinet's controller (including EAL alarms) must be accompanied by additional redundant independent external alarms to ensure maximum item safety.

External acoustic settings

O-16*: BU – Activation/deactivation of the acoustic external alarms

- ↳ Press and hold (P) + (1) for more than 3 seconds
- ↳ Press (+) to proceed to "EAL"
- ↳ Press (P) to select "EAL". "EhL" is now shown in the display
- ↳ Press (+) several times until "BU" is shown in the display
- ↳ Press (P) to select "BU"
- ↳ Press (-) or (+) to activate/deactivate the external acoustic alarms [1=activated/0=deactivated]
- ↳ Press (P) to confirm the set value
 - The external acoustic alarms is configured, proceed to other parameters by pressing (U), then navigate by using (-) or (+)
- ↳ Leave the user menu by pressing (U) several times until the cabinet's temperature is shown in the display



- ATTENTION -

High and low-temperature alarms set up in the cabinet's controller (including EAL alarms) must be accompanied by additional redundant independent external alarms to ensure maximum item safety.

Sensor offset

The following part covers the offset of the A-sensor, the E-sensor, and the F-sensor.

The temperature sensors connected to the MPC controller can be offset independently of each other in the parameter settings cAL.

Offset is used in cases where there are deviations in the cabinet's actual operation compared to the display and/or control measurements by independent temperature monitoring.

The cabinet is equipped with an A-sensor, an E-sensor and an optional F-sensor.

The A-sensor is used to manage the cabinet's refrigeration system and is fixated in a given position in the cabinet, not in storage space. The location of the A-sensor must not be altered.

The A-sensor should be offset if the actual temperature in the cabinet does not match the setpoint, despite taking the hysteresis into consideration. Offset of A-sensor is named "cA".

The E-sensor is placed in the cabinet storage space and can be moved around in the cabinet to get the desired reference point for temperature. The E-sensor is the default display sensor and reference for the alarms. The E-sensor has no effect on control of the refrigeration system.

The E-sensor should be offset if the actual temperature in the cabinet's display, provided that the display sensor for reference is the E-sensor, does not match the independent temperature monitoring used for control. Offset of E-sensor is named "cE"

The F-sensor is placed inside the storage space, close to the airflow of the cold air exiting the air distribution system. The location of the F-sensor must not be altered as this will have an effect on when the low-temperature protection activates.

The F-sensor should be offset if the cut-off temperature for the low-temperature protection, does not match the setpoint temperature for the low-temperature protection. Offset of the F-sensor is named "cF".

Practical example of offset

Example 1 – The temperature in the cabinet is operating colder than the actual setpoint.

With a setpoint of +4 °C, the actual temperature inside the cabinet is between +2 °C and +4 °C. The desired temperature range is between +3 °C and +5 °C. This means that "cA", in this case, should be -1.0K, so that the refrigeration system stops 1.0K before and starts 1.0K later than the setpoint normally otherwise would dictate.

Example 2 – The temperature in the cabinet is operating warmer than the actual setpoint.

With a setpoint of +4 °C, the actual temperature inside the cabinet is between +4 °C and +6 °C. The desired temperature range is between +3 °C and +5 °C. This means that "cA", in this case, should be +1.0K, so that the refrigeration system stops 1.0K later and starts 1.0K earlier than the setpoint normally otherwise would dictate.

Offset of the A-sensor

- ↳ Press and hold $\text{P} + \text{1}$ for more than 3 seconds
- ↳ Press + several times until "cAL" is shown in the display
- ↳ Press P to select "cAL". "cA" is shown in the display
- ↳ Press P to select "cA"
- ↳ Press - or + to offset the A-sensor
- ↳ Press P to confirm the set value
 - The A-sensor is now offset, proceed to other parameters by pressing ⏻ , then navigate by using - or +
- ↳ Leave the user menu by pressing ⏻ several times until the cabinet's temperature is shown in the display

Offset of the E-sensor

- ↳ Press and hold $\text{P} + \text{1}$ for more than 3 seconds
- ↳ Press + several times until "cAL" is shown in the display
- ↳ Press P to select "cAL". "cA" is shown in the display
- ↳ Press + until "cE" is shown in the display
- ↳ Press P to select "cE"
- ↳ Press - or + to offset the E-sensor
- ↳ Press P to confirm the set value
 - The E-sensor is now offset proceed to other parameters by pressing ⏻ , then navigate by using - or +
- ↳ Leave the user menu by pressing ⏻ several times until the cabinet's temperature is shown in the display

Offset of the F-sensor

- ↳ Press and hold $\text{P} + \text{1}$ for more than 3 seconds
- ↳ Press + several times until "cAL" is shown in the display
- ↳ Press P to select "cAL". "cA" is shown in the display
- ↳ Press + until "cF" is shown in the display
- ↳ Press P to select "cF"
- ↳ Press - or + to offset the F-sensor
- ↳ Press P to confirm the set value
 - The F-sensor is now offset proceed to other parameters by pressing ⏻ , then navigate by using - or +
- ↳ Leave the user menu by pressing ⏻ several times until the cabinet's temperature is shown in the display

Escorted/set alarm limits

The following part covers the setting of escorted or set alarm limits.

ALL – Setting of escorted/set alarm limits

- ↳ Press and hold (P) + (1) for more than 3 seconds
- ↳ Press (+) several times until “ALL” is shown in the display
- ↳ Press (P) to select “ALL”
- ↳ Press (-) or (+) to select set or escorted alarm limits
- ↳ Press (P) to confirm the set value
- ↳ Leave the user menu by pressing (⏻) several times until the cabinet’s temperature is shown in the display

“**Set alarm**” is fixed, operating independently from the setpoint. The temperature alarm limits will remain the selected values regardless of the setpoint being altered.

“**Escorted alarm**” is fixed and locked to the setpoint. The temperature alarm limits will change according to the altered setpoint.



– ATTENTION –

High and low-temperature alarms set up in the cabinet’s controller (including EAL alarms) must be accompanied by additional redundant independent external alarms to ensure maximum item safety.

Defrosts/24 hours

The following part covers the setting of defrosts/24 hours.

O-17*: dEF – Number of defrosts

- ↳ Press and hold (P) + (1) for more than 3 seconds
- ↳ Press (+) several times until "dEF" is shown in the display
- ↳ Press (P) to select "dEF"
- ↳ Press (-) or (+) to set the desired amount of defrosts per 24 hours (factory setting is 4)
- ↳ Press (P) to confirm the set value
- ↳ Leave the user menu by pressing (⏻) several times until the cabinet's temperature is shown in the display

Please note: It is very important that defrosts should not be set to 0 for a prolonged period of time, as this will reduce the cooling capacity of the cabinet.



- ATTENTION -

High and low-temperature alarms set up in the cabinet's controller (including EAL alarms) must be accompanied by additional redundant independent external alarms to ensure maximum item safety.

Display sensor

The following part covers the setting of which sensor to be shown in the display.

O-18*: dPS – Display sensor

- ↳ Press and hold (P) + (1) for more than 3 seconds
- ↳ Press (+) several times until “dPS” is shown in the display
- ↳ Press (P) to select “dPS”
- ↳ Press (-) or (+) to select either the A- or E-sensor
- ↳ Press (P) to confirm the set value
- ↳ Leave the user menu by pressing (⏻) several times until the cabinet’s temperature is shown in the display



The dPS only changes the reference sensor for the display, and not the reference sensor for the alarms.



The reference sensor for the refrigeration system is the A-sensor, this cannot be altered.



– ATTENTION –

High and low-temperature alarms set up in the cabinet’s controller (including EAL alarms) must be accompanied by additional redundant independent external alarms to ensure maximum item safety.

Electric low-temperature protection

The following part covers the electric low-temperature protection.

FP – Activation/deactivation of low-temperature protection

- ↳ Press and hold (P) + (1) for more than 3 seconds
- ↳ Press (+) several times until "FP" is shown in the display
- ↳ Press (P) to select "FP". "Act" is now shown in the display
- ↳ Press (P) to select "Act"
- ↳ Press (-) or (+) to activate/deactivate [1=activated/0=deactivated]
- ↳ Press (P) to confirm the set value
- ↳ Leave the user menu by pressing (⏪) several times until the cabinet's temperature is shown in the display

FP – Setpoint of low-temperature protection

- ↳ Press and hold (P) + (1) for more than 3 seconds
- ↳ Press (+) several times until "FP" is shown in the display
- ↳ Press (P) to select "FP". "Act" is now shown in the display
- ↳ Press (+) several times until "SEt" is shown in the display
- ↳ Press (P) to select "SEt"
- ↳ Press (-) or (+) to select the setpoint temperature for the low-temperature protection
- ↳ Press (P) to confirm the set value
- ↳ Leave the user menu by pressing (⏪) several times until the cabinet's temperature is shown in the display

FP – Test of low-temperature protection

- ↳ Press and hold (P) + (1) for more than 3 seconds
- ↳ Press (+) several times until "FP" is shown in the display
- ↳ Press (P) to select "FP". "Act" is now shown in the display
- ↳ Press (+) to progress to "tES"
- ↳ Press (P) to select "tES" – test will then be performed
- ↳ Leave the user menu by pressing (⏪) several times until the cabinet's temperature is shown in the display

FP – Temperature of low-temperature protection sensor

- ↳ Press and hold (P) + (1) for more than 3 seconds
- ↳ Press (+) several times until "FP" is shown in the display
- ↳ Press (P) to select "FP". "Act" is now shown in the display
- ↳ Press (+) several times until "Pre" is shown in the display
- ↳ Press (P) to select "Pre"
- ↳ Press (P) to show the low-temperature protection sensor temperature
- ↳ Leave the user menu by pressing (⏪) several times until the cabinet's temperature is shown in the display

Load line

The following part shows how items should be placed and stored in the cabinet

Keep the marked areas in the cabinet (as shown) clear of all items, thereby ensuring adequate air circulation, and therein cooling.

Do not place items beneath the lowest shelf bracket. All items in the cabinet that are not encapsulated, or wrapped, should be covered to reduce the risk of corrosion of the cabinet and its components.



Items placed on the bottom of the cabinet will cause the air circulation to be impeded, which reduces the cabinet's performance. The items should be evenly distributed in the cabinet, with minimum layer-thickness/maximum surface. At the same time, the air should be able to circulate freely between the items.

The cabinet is not suited for storing items that emit vapours, as they might corrode the cabinet and its components.



The cabinet's interior must not be exposed to corrosive atmospheres.

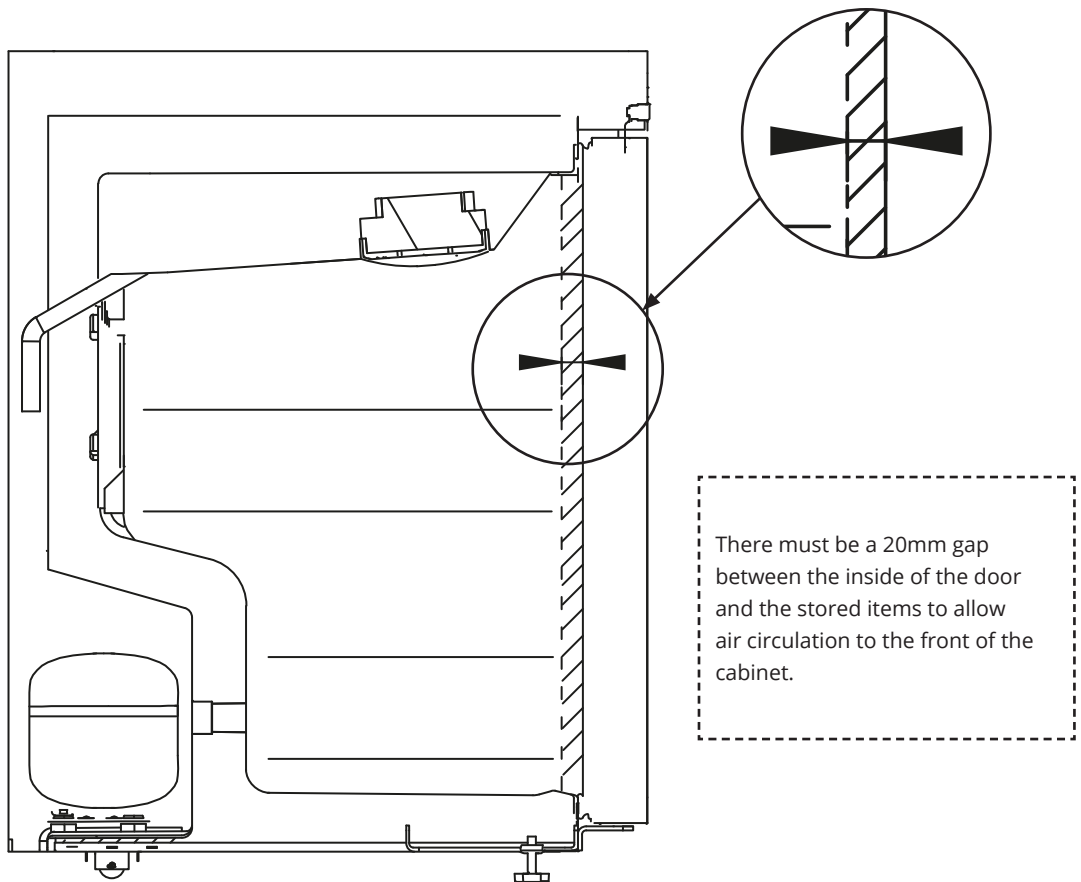

Load line - BioCompact II 410

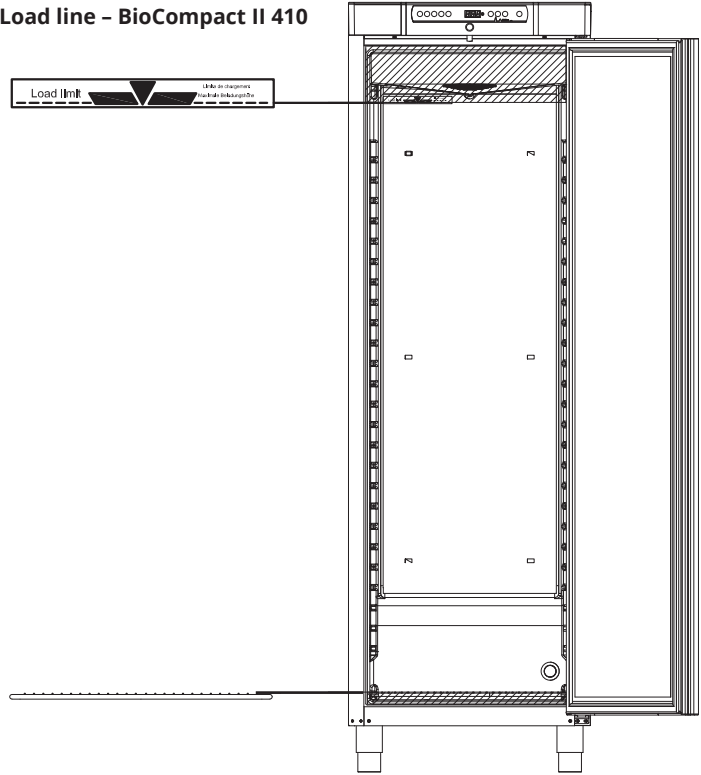

Load line - BioCompact II 610

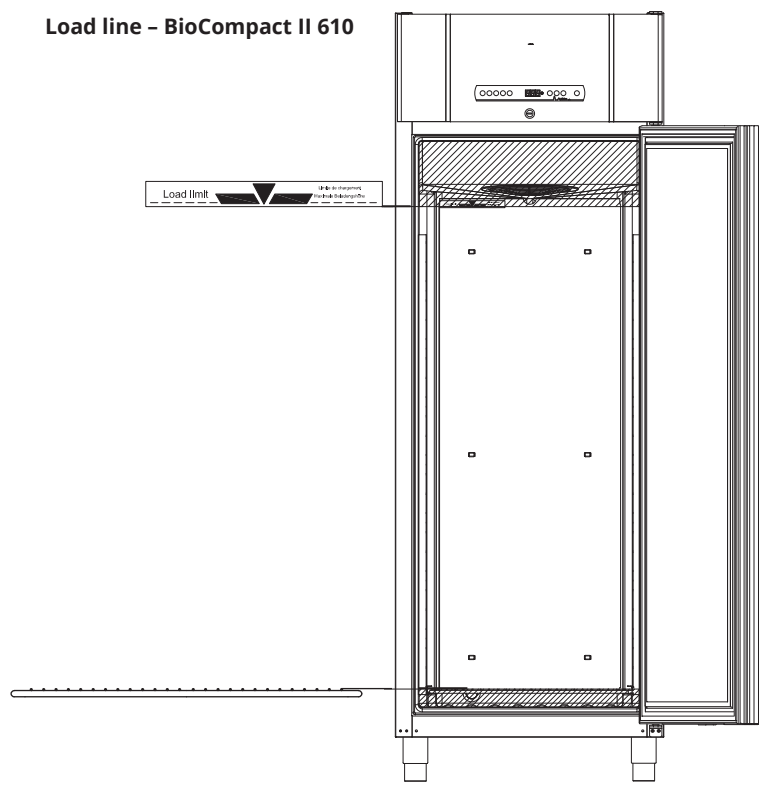

Door lock

The BioCompact II cabinets are equipped with a safety lock.

The illustration below shows the safety lock.

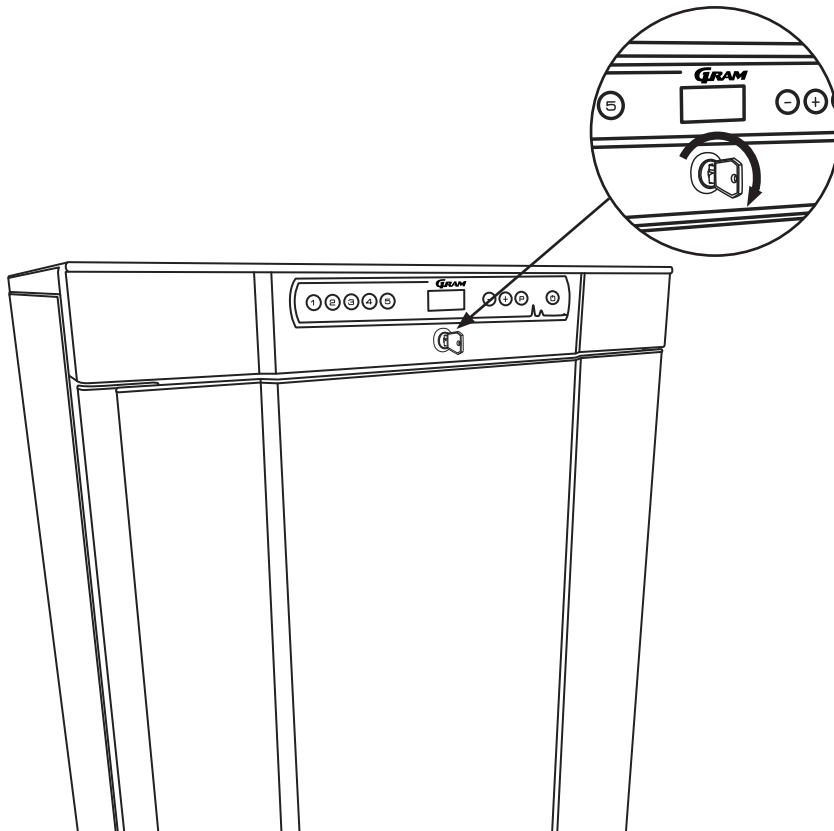

Regular maintenance

Cleaning

Inadequate cleaning can lead to the cabinet not functioning properly or at all.



The cabinet should be cleaned internally with a mild soap solution (max. 85 °C) at suitable intervals and checked thoroughly before it is put into operation again.

Cleaning agents with a pH of 5 ± 1 can be used, if a mild soap solution or water is used to remove any substance that might damage cabinet components or surfaces. The cleaning agent should be compatible with materials such as steel, alloy, sheet metal, paint, and plastics.

The compressor compartment and in particular the condenser must be kept free from dust and dirt. This can be done with a vacuum cleaner and a brush.

It is recommended that the re-evaporation tray is checked regularly for foreign objects and cleaned accordingly.

Do not flush the compressor compartment or evaporator with water.

Cleaning agents containing chlorine or compounds of chlorine as well as other corrosive agents, may not be used, as they may cause corrosion.

The location of the condensers for both bottom- and top-mounted compressors are illustrated below.

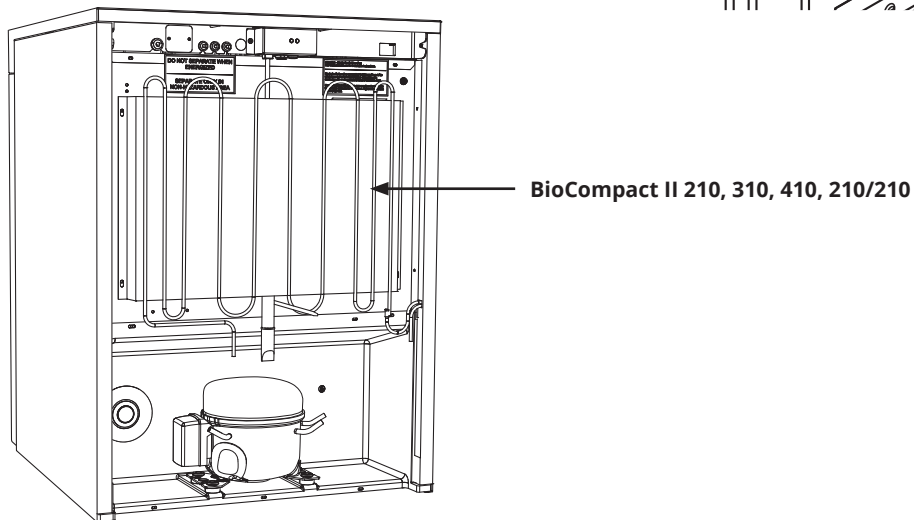
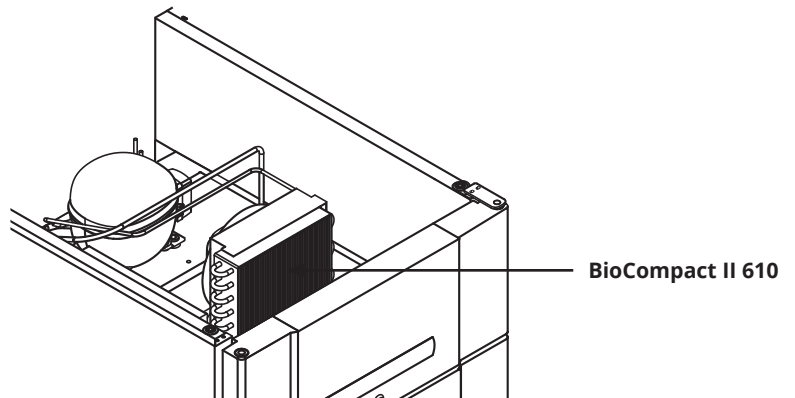

Door gasket

The following part covers the importance of a properly functioning door gasket.

The door gasket is an important part of the cabinet. Impaired door gaskets can lead to increased humidity, iced up evaporator (thus reduced cooling capacity), and in some cases, decreased longevity of the cabinet.

It is therefore very important to be aware of the door gasket's condition. Regular inspection is recommended.

The door gasket should be cleaned regularly with a mild soap solution. If the gasket is to be replaced, please contact your local Gram BioLine distributor.

The illustration below shows the location of the door gasket.

BioCompact II 410

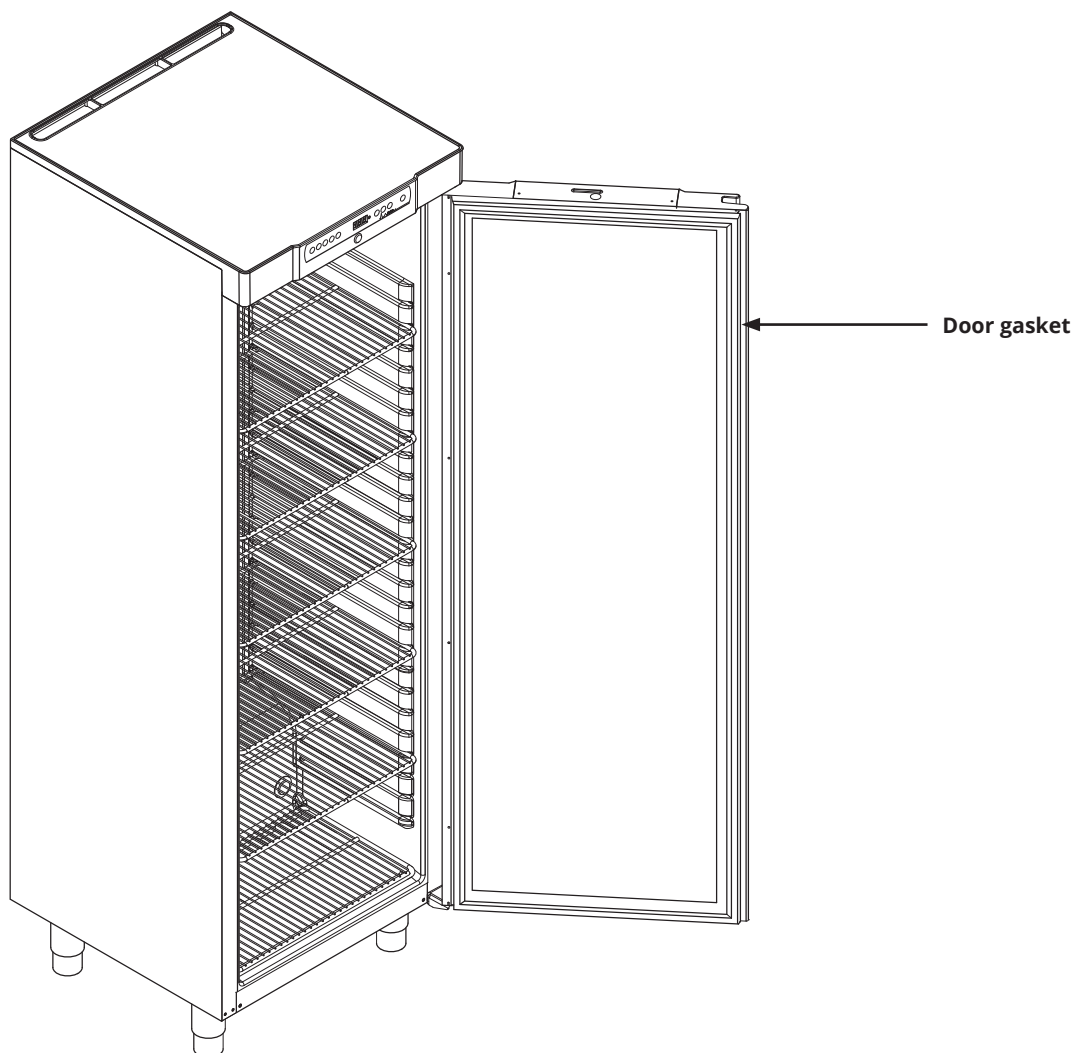

General info

Service

Read the following carefully, for information on technical safety and responsibility on Gram BioLine products.



- WARNING -

DO NOT OPEN, MAINTAIN OR SERVICE
IN AN AREA WHEN AN EXPLOSIVE
ATMOSPHERE IS PRESENT



When servicing make sure the appliance is switched off at the socket before service is performed on the cabinet.
It is not sufficient to switch the cabinet to standby on the standby (⏻) key, as current will persist in some electrical parts of the cabinet.



Warranty may be void in the event of the cabinet being used for applications other than its intended use, or otherwise not in accordance with the guidelines stipulated in the instructions for use.



Defective parts must be replaced with original parts from Gram BioLine. Gram BioLine can only guarantee functional and safety requirements on the cabinets, if above mentioned is adhered to.



The cabinet should be checked at least once yearly by a Gram BioLine authorised technician.
The refrigeration system and the hermetically sealed compressor require no maintenance.
However the condenser requires regular cleaning.



Be aware that cabinets using hydrocarbons (HC) as refrigerant, may require special handling by qualified technicians.

Type/number plate

The following part describes where to find the type/number plate.

If refrigeration fails, first look to see whether the cabinet has been unintentionally switched off, or whether a fuse has blown.

If the cause of failure cannot be found, contact your supplier quoting type and S/N. This information can be found on the type/number plate.

Type No. plate – BioCompact II 610

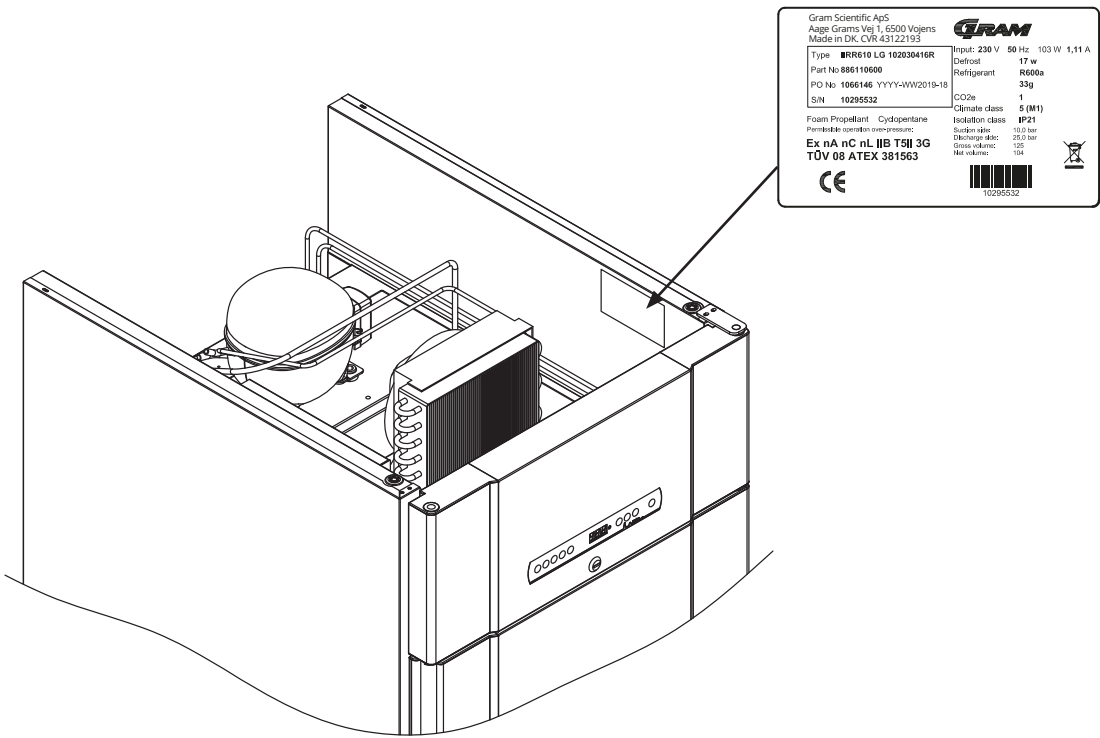

Type No. plate – BioCompact II 210

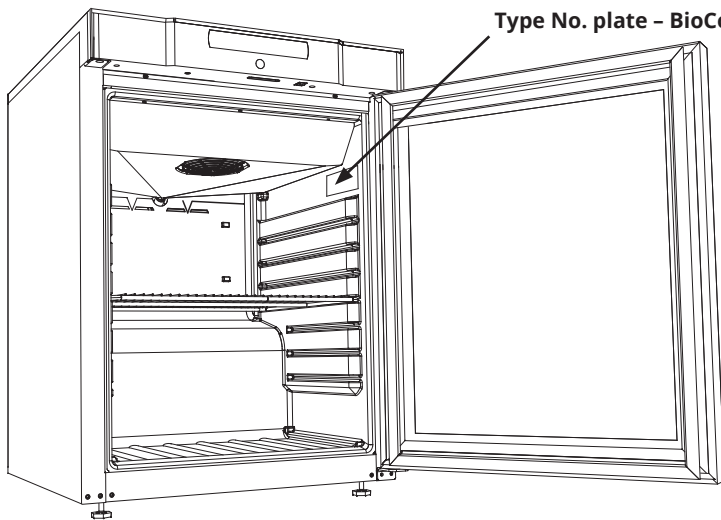

Defrost water

The cabinet creates defrost water, that is directed out into a re-evaporation tray at the back of the cabinet.

The cabinet creates defrost water, which is directed into the re-evaporation tray at the back of the cabinet.

BioCompact II 610

Defrost water is led through a tube in the insulation to the re-evaporation tray at the back of the cabinet.

BioCompact II 210, 310, 210/210, 310/210, and 410

Defrost water is led through a tube in the insulation to the re-evaporation tray in the compressor room in the cabinet.

Below the re-evaporation trays for a BioCompact II 410 and BioCompact II 610 are shown.



It is recommended that the re-evaporation tray is checked regularly for foreign objects and cleaned accordingly. This shall only be done while the cabinet is turned off.

Be careful not to damage the defrost water tube and the heating element (located in the tray) when cleaning.

BioCompact II 410

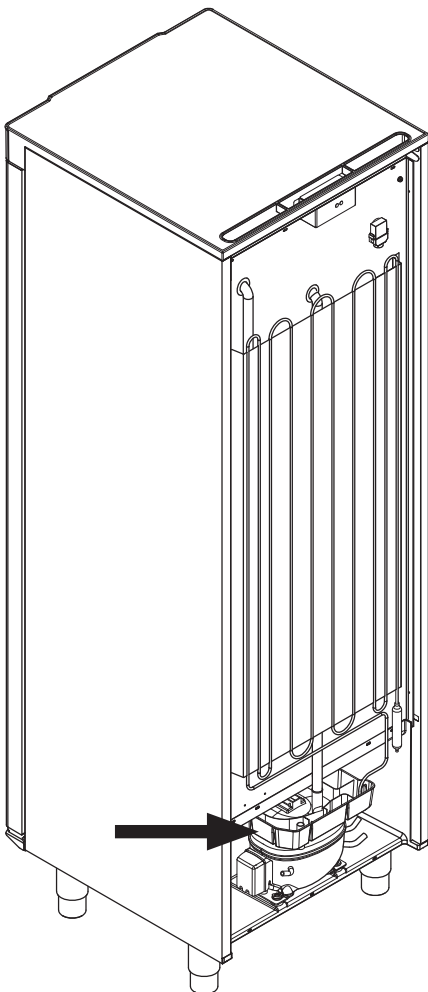

BioCompact II 610

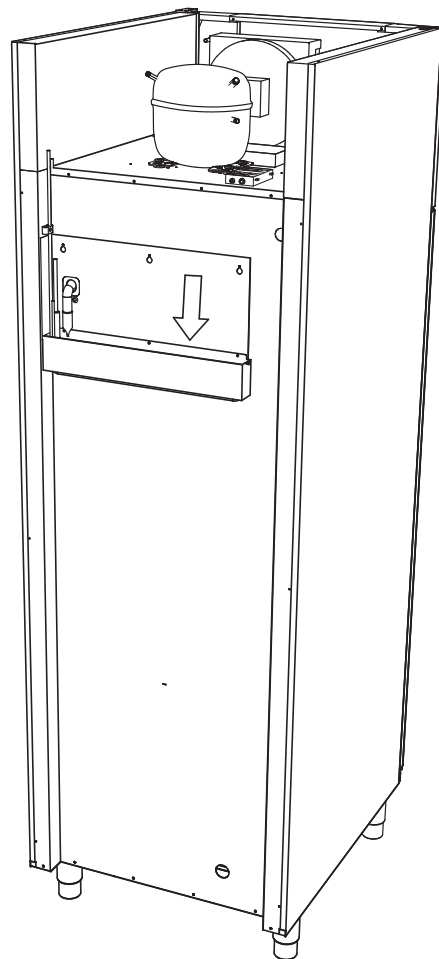

Access port

All BioCompact II cabinets are equipped with an access port on the back of the cabinets.
This can be used to easily fit external sensors.

All access ports are constructed in the same fashion, with a conical polystyrene plug (fitted from the back of the cabinet) and a plastic cap (fitted from the inside of the cabinet).



It is very important to refit the polystyrene plug and plastic cap after mounting a sensor, probe etc. Failing to do so can result in lowered performance or malfunction of the cabinet.

Access ports are clearly marked "Access port" on the cabinet. Find the location on this page.

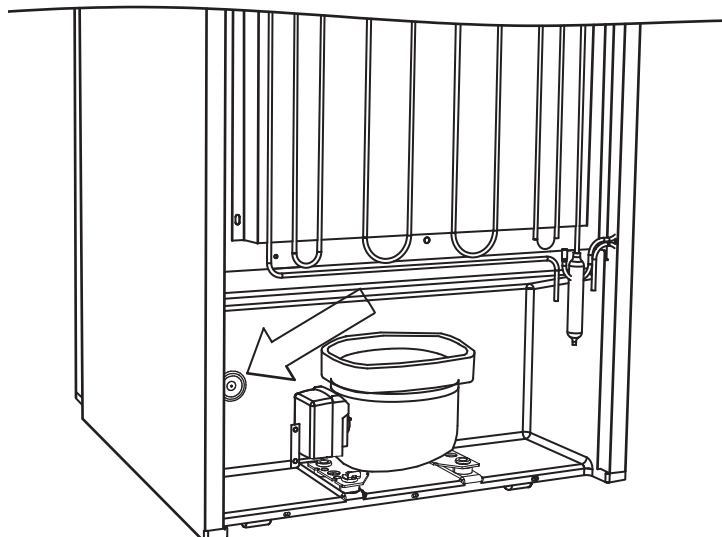
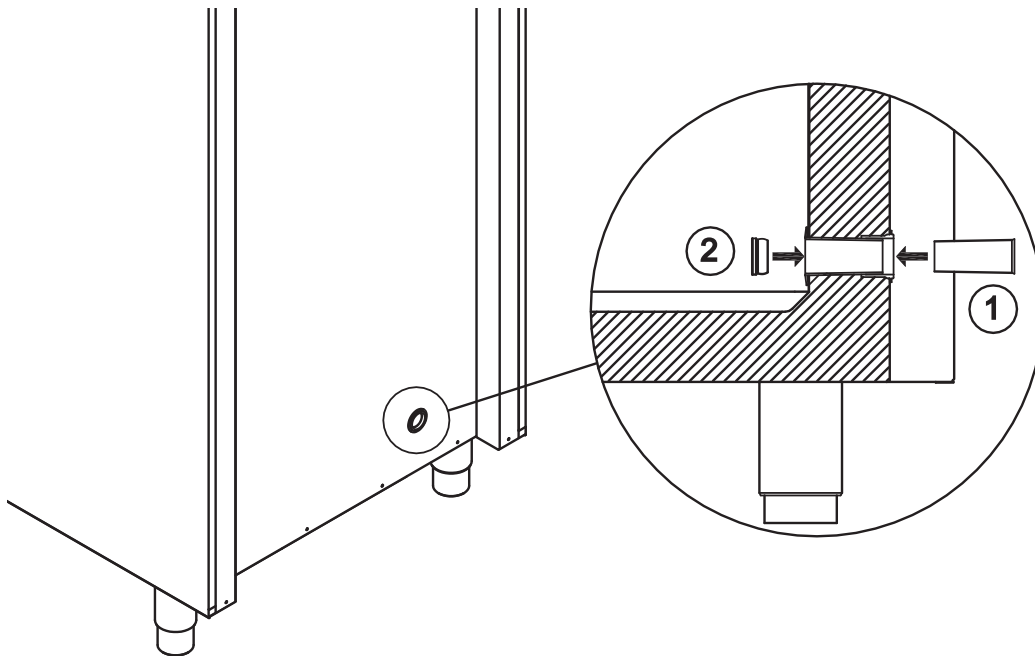

Important

In the event of need for product support, do not hesitate to contact us at: support@gram-bioline.com.



– IMPORTANT –

1. There may be sharp edges on the cabinet, compressor room, and interior, show due diligence when handling the cabinet, negligence of these precautions can lead to injuries.
2. Be cautious about the potential risk of body parts getting wedged in the frame slot between the door and the cabinet when opening or closing the cabinet. Exercise due diligence to avoid any accidents. Failure to take these precautions may result in injuries.
3. Exercise caution to prevent the potential wedging of body parts in the drawer column between the drawers and the interior of the cabinet. Demonstrate due diligence to avoid accidents, as negligence in observing these precautions may lead to injuries.
4. Be particularly vigilant in relation to closing doors with self-close mechanism as these are spring-loaded. Negligence of these precautions can lead to injuries.
5. Unlocked castors can lead to unexpected movements of the cabinet. Lock the castors after installation. Negligence of these precautions can lead to injuries.
6. The re-evaporation tray, re-evaporation tray heating element, pressure pipes and compressor develops considerable heat during operation. Assure yourself that these components are sufficiently tempered before touching. Negligence of these precautions can lead to injuries.
7. The evaporator develops considerable cold during operation. Reassure yourself that the evaporator is sufficiently tempered before touching. Negligence of this precaution may lead to injuries.
8. The fan may cause injury during operation, avoiding touching the fans while the cabinet is connected to the mains. Negligence of these precautions can lead to injuries.
9. No unauthorised modifications are allowed.

Disposal

The following part covers the disposal of electrical and electronic equipment.

At Gram BioLine we are dedicated to environmental sustainability and comply fully with the Waste Electrical and Electronic Equipment (WEEE) Directive.

Electrical and electronic equipment (EEE) contains materials, components and substances that can be dangerous and harmful to human health and the environment if the waste (WEEE) is not disposed of correctly. When disposing the appliance in an EU Member State, it should be in accordance with the Waste Electrical and Electronic Equipment Regulations (WEEE).

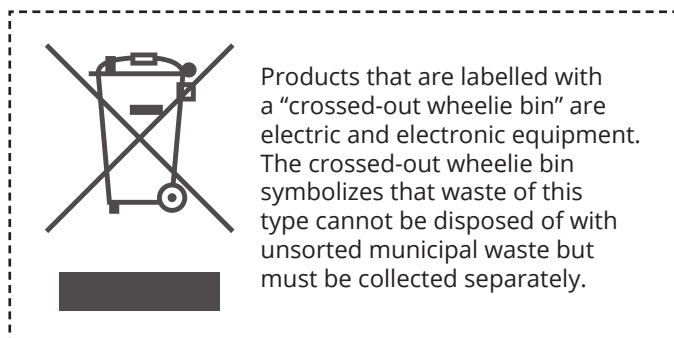

This refrigerator or freezer is specifically designed for bioscience purposes, it is therefore important to thoroughly clean the appliance to ensure that no residues or harmful substances remain. While it is not a requirement under the (WEEE) Directive to document the cleaning, it is considered good practice to ensure the refrigerator is free of contamination before it is sent for recycling or disposal. This helps protect individuals responsible for handling the appliance and ensures a safe and environmentally friendly recycling process.

Correct disposal and recycling of electrical and electronic equipment help reduce waste and minimize environmental impact. By adhering to proper handling practices, your organization supports pollution prevention and resource conservation. Recycled materials are sorted, cleaned, and processed for reuse, contributing to sustainability and reducing the need for new raw materials.

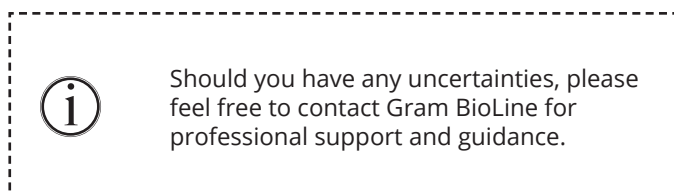

Datasheet

BioCompact II 210, 310, 410, 210/210, 310/210

General data:

BioCompact II 210, 310, 410, 210/210, 310/210

Technical specifications	Data
Connection	230 VAC, 50 Hz
Control Unit	Gram Control Unit with voltage-free contact, alarms and offset function
Alarms	Acoustic and visual, High/Low-temperature alarms and door alarm
Alarm ports	Voltage-free contact
Access port	1 pc. ø24.5 mm
Door	Right or left hinged
Material interior	PS lining
Material exterior	White lacquered steel or stainless steel finish
Insulation	50 mm polyurethane with HFC-free cyclopentane propellant
Air system	BioLine ventilated air distribution system
Defrost system	Automatic smart defrost with re-evaporation of defrost water
IP class	IP21

BioCompact II RR210 H

BioCompact II RR210 H – with solid door

Technical specifications	Data
Temperature range	+2/+20 °C
Ambient temperature range	+10/+35 °C
Software variant	K82
K-Value	0.36 W/(m ² *K)
ATEX marking	II 3G Ex ec nC ic IIB T5 Gc
ATEX certificate	DTI 22ATEX0251X
Gross volume	125 litres
Net volume	104 litres
Dimensions – W x D x H	595 x 640 x 801/1001mm
Refrigerant	R134a
Refrigerant charge	80 g
Refrigeration capacity at -10 °C	150 Watt
GWP – CO ₂ e	114.4
Energy consumption – default setpoint	0.5 kWh/24h
Heat emission 100 %	119 Watt
Heat emission default setpoint	21 Watt
Nominal consumption	110 Watt
Start current	6.9A
Sound level	–

BioCompact II RR210 H – with glass door

Technical specifications	Data
Temperature range	+2/+20 °C
Ambient temperature range	+10/+32 °C
Software variant	K92
K-Value	0.5514 W/(m ² *K)
ATEX marking	II 3G Ex ec nC ic IIB T5 Gc
ATEX certificate	DTI 22ATEX0251X
Gross volume	125 litres
Net volume	104 litres
Dimensions – W x D x H	595 x 640 x 801/1001 mm
Refrigerant	R134a
Refrigerant charge	80 g
Refrigeration capacity at -10 °C	220 Watt
GWP – CO ₂ e	114.4
Energy consumption – default setpoint	0.970 kWh/24h
Heat emission 100 %	173 Watt
Heat emission default setpoint	40 Watt
Nominal consumption	188 Watt
Start current	9.7A
Sound level	–

BioCompact II RR310 H

BioCompact II RR310 H – with solid door

Technical specifications	Data
Temperature range	+2/+20 °C
Ambient temperature range	+10/+35 °C
Software variant	K82
K-Value	0.355 W/(m ² *K)
ATEX marking	II 3G Ex ec nC ic IIB T5 Gc
ATEX certificate	DTI 22ATEX0251X
Gross volume	218 litres
Net volume	189 litres
Dimensions – W x D x H	595 x 640 x 1190/1390 mm
Refrigerant	R134a
Refrigerant charge	115 g
Refrigeration capacity at -10 °C	173 Watt
GWP – CO ₂ e	164.45
Energy consumption – default setpoint	0.540 kWh/24h
Heat emission 100 %	137 Watt
Heat emission default setpoint	22 Watt
Nominal consumption	145 Watt
Start current	8.6A
Sound level	–

BioCompact II RR310 H – with glass door

Technical specifications	Data
Temperature range	+2/+20 °C
Ambient temperature range	+10/+32 °C
Software variant	K92
K-Value	0.50 W/(m ² *K)
ATEX marking	II 3G Ex ec nC ic IIB T5 Gc
ATEX certificate	DTI 22ATEX0251X
Gross volume	218 litres
Net volume	189 litres
Dimensions – W x D x H	595 x 640 x 1190/1390 mm
Refrigerant	R134a
Refrigerant charge	95 g
Refrigeration capacity at -10 °C	220 Watt
GWP – CO ₂ e	135.85
Energy consumption – default setpoint	–
Heat emission 100 %	–
Heat emission default setpoint	–
Nominal consumption	183 Watt
Start current	9.7A
Sound level	–

BioCompact II RR410 H

BioCompact II RR410 H – with solid door

Technical specifications	Data
Temperature range	+2/+20 °C
Ambient temperature range	+10/+35 °C
Software variant	K82
K-Value	0.35 W/(m ² *K)
ATEX marking	II 3G Ex ec nC ic IIB T4 Gc
ATEX certificate	DTI 22ATEX0251X
Gross volume	346 litres
Net volume	312 litres
Dimensions – W x D x H	595 x 640 x 1776/1976 mm
Refrigerant	R134a
Refrigerant charge	120 g
Refrigeration capacity at -10 °C	173 Watt
GWP – CO ₂ e	171.6
Energy consumption – default setpoint	0.706 kWh/24 h
Heat emission 100 %	132 Watt
Heat emission default setpoint	29 Watt
Nominal consumption	140 Watt
Start current	8.6A
Sound level	–

BioCompact II RR410 H – with glass door

Technical specifications	Data
Temperature range	+2/+20 °C
Ambient temperature range	+10/+32 °C
Software variant	K92
K-Value	0.5375 W/(m ² *K)
ATEX marking	II 3G Ex ec nC ic IIB T4 Gc
ATEX certificate	DTI 22ATEX0251X
Gross volume	346 litres
Net volume	312 litres
Dimensions – W x D x H	595 x 640 x 1776/1976 mm
Refrigerant	R134a
Refrigerant charge	120 g
Refrigeration capacity at -10 °C	314 Watt
GWP – CO ₂ e	171.6
Energy consumption – default setpoint	–
Heat emission 100 %	–
Heat emission default setpoint	–
Nominal consumption	197 Watt
Start current	5.9A
Sound level	–

BioCompact II RF210 H

BioCompact II RF310 H

BioCompact II RF210 H – with solid door

Technical specifications	Data
Temperature range	-25/-5 °C
Ambient temperature range	+10/+35 °C
Software variant	F52
K-Value	0.3559 W/(m ² *K)
ATEX marking	II 3G Ex ec nC ic IIB T3 Gc
ATEX certificate	DTI 22ATEX0251X
Gross volume	125 litres
Net volume	104 litres
Dimensions – W x D x H	595 x 640 x 801/1001 mm
Refrigerant	R134a
Refrigerant charge	70 g
Refrigeration capacity at -25 °C	149 Watt
GWP – CO ₂ e	100.1
Energy consumption – default setpoint	1.49 kWh/24h
Heat emission 100 %	148 Watt
Heat emission default setpoint	66 Watt
Nominal consumption	158 Watt
Start current	5.9A
Sound level	–

BioCompact II RF310 H – with solid door

Technical specifications	Data
Temperature range	-25/-5 °C
Ambient temperature range	+10/+35 °C
Software variant	F52
K-Value	0.355 W/(m ² *K)
ATEX marking	II 3G Ex ec nC ic IIB T3 Gc
ATEX certificate	DTI 22ATEX0251X
Gross volume	218 litres
Net volume	189 litres
Dimensions – W x D x H	595 x 640 x 1190/1390 mm
Refrigerant	R134a
Refrigerant charge	80 g
Refrigeration capacity at -25 °C	216 Watt
GWP – CO ₂ e	114.4
Energy consumption – default setpoint	–
Heat emission 100 %	–
Heat emission default setpoint	–
Nominal consumption	187 Watt
Start current	11.3A
Sound level	–

BioCompact II RF410 H

BioCompact II RF410 H - with solid door

Technical specifications	Data
Temperature range	-25/-5 °C
Ambient temperature range	+10/+35 °C
Software variant	F52
K-Value	0.35 W/(m ² *K)
ATEX marking	II 3G Ex ec nC ic IIB T3 Gc
ATEX certificate	DTI 22ATEX0251X
Gross volume	346 litres
Net volume	312 litres
Dimensions – W x D x H	595 x 640 x 1776/1976 mm
Refrigerant	R134a
Refrigerant charge	95 g
Refrigeration capacity at -25 °C	216 Watt
GWP – CO ₂ e	135.85
Energy consumption – default setpoint	2.285 kWh/24h
Heat emission 100 %	174 Watt
Heat emission default setpoint	95 Watt
Nominal consumption	191 Watt
Start current	11.3A
Sound level	-

BioCompact II RR210/RR210 H

BioCompact II RR210/RR210 H - with solid door

Technical specifications	Data
Temperature range	+2/+20 °C
Ambient temperature range	+10/+35 °C
Software variant	K82
K-Value	0.36 W/(m ² *K);
ATEX marking	II 3G Ex ec nC ic IIB T3 Gc
ATEX certificate	DTI 22ATEX0251X
Gross volume	2 x 125 litres
Net volume	2 x 104 litres
Dimensions – W x D x H	595 x 640 x 1602/1802 mm
Refrigerant	R134a
Refrigerant charge	2 x 80 g
Refrigeration capacity at -10 °C	2 x 150 Watt
GWP – CO ₂ e	2 x 114.4
Energy consumption – default setpoint	2 x 0.5 kWh/24h
Heat emission 100 %	2 x 119 Watt
Heat emission default setpoint	2 x 21 Watt
Nominal consumption	2 x 110 Watt
Start current	2 x 6.9A
Sound level	-

BioCompact II RR210/RR210 H - with glass door

Technical specifications	Data
Temperature range	+2/+20 °C
Ambient temperature range	+10/+32 °C
Software variant	K92
K-Value	0.5114 W/(m ² *K)
ATEX marking	II 3G Ex ec nC ic IIB T3 Gc
ATEX certificate	DTI 22ATEX0251X
Gross volume	2 x 125 litres
Net volume	2 x 104 litres
Dimensions – W x D x H	595 x 640 x 1602/1802 mm
Refrigerant	R134a
Refrigerant charge	2 x 80 g
Refrigeration capacity at -10 °C	2 x 220 Watt
GWP – CO ₂ e	2 x 114.4
Energy consumption – default setpoint	2 x 0.970 kWh/24h
Heat emission 100 %	2 x 173 Watt
Heat emission default setpoint	2 x 40 Watt
Nominal consumption	2 x 188 Watt
Start current	2 x 9.7A
Sound level	-

BioCompact II RR210/RF210 H

BioCompact II RR210/RF210 H - with solid door

Technical specifications	Data
Temperature range	RR210: +2/+20 °C RF210: -25/-5 °C
Ambient temperature range	RR210: +10/+35 °C RF210: +10/+35 °C
Software variant	RR210: K82 RF210: F52
K-Value	RR210: 0.3559 W/(m ² *K) RF210: 0.3559 W/(m ² *K)
ATEX marking	II 3G Ex ec nC ic IIB T3 Gc
ATEX certificate	DTI 22ATEX0251X
Gross volume	RR210: 125 litres RF210: 125 litres
Net volume	RR210: 104 litres RF210: 104 litres
Dimensions – W x D x H	595 x 640 x 1602/1802 mm
Refrigerant	R134a
Refrigerant charge	RR210: 80 g RF210: 70 g
Refrigeration capacity at -10 °C	150 Watt
Refrigeration capacity at -25 °C	149 Watt
GWP – CO ₂ e	RR210: 114.4 RF210: 100.1
Energy consumption – default setpoint	RR210: 0.5 kWh/24h RF210: 1.584 kWh/24h
Heat emission 100 %	RR210: 119 Watt RF210: 148 Watt
Heat emission default setpoint	RR210: 21 Watt RF210: 66 Watt
Nominal consumption	RR210: 110 Watt RF210: 158.1 Watt
Start current	RR210: 6.9A RF210: 5.9A
Sound level	-

BioCompact II RR210/RF210 H - with glass door (RR)

Technical specifications	Data
Temperature range	RR210: +2/+20 °C RF210: -25/-5 °C
Ambient temperature range	RR210: +10/+32 °C RF210: +10/+35 °C
Software variant	RR210: K92 RF210: F52
K-Value	RR210: 0.5114 W/(m ² *K) RF210: 0.3559 W/(m ² *K)
ATEX marking	II 3G Ex ec nC ic IIB T3 Gc
ATEX certificate	DTI 22ATEX0251X
Gross volume	RR210: 125 litres RF210: 125 litres
Net volume	RR210: 104 litres RF210: 104 litres
Dimensions – W x D x H	595 x 640 x 1602/1802 mm
Refrigerant	R134a
Refrigerant charge	RR210: 80 g RF210: 70 g
Refrigeration capacity at -10 °C	150 Watt
Refrigeration capacity at -25 °C	149 Watt
GWP – CO ₂ e	RR210: 114.4 RF210: 100.1
Energy consumption – default setpoint	RR210: 0.970 kWh/24h RF210: 1.584 kWh/24h
Heat emission 100 %	RR210: 173 Watt RF210: 148 Watt
Heat emission default setpoint	RR210: 40 Watt RF210: 66 Watt
Nominal consumption	RR210: 188 Watt RF210: 158.1 Watt
Start current	RR210: 9.7A RF210: 5.9A
Sound level	-

BioCompact II RF210/RF210 H

BioCompact II RF210/RF210 H - with solid door

Technical specifications	Data
Temperature range	-25/-5 °C
Ambient temperature range	+10/+35 °C
Software variant	F52
K-Value	0.3559 W/(m ² *K)
ATEX marking	II 3G Ex ec nC ic IIB T3 Gc
ATEX certificate	DTI 22ATEX0251X
Gross volume	2 x 125 litres
Net volume	2 x 104 litres
Dimensions – W x D x H	595 x 640 x 1602/1802 mm
Refrigerant	R134a
Refrigerant charge	2 x 70 g
Refrigeration capacity at -25 °C	2 x 149 Watt
GWP – CO ₂ e	2 x 100.1
Energy consumption – default setpoint	2 x 1.584 kWh/24h
Heat emission 100 %	2 x 148 Watt
Heat emission default setpoint	2 x 66 Watt
Nominal consumption	2 x 158.1 Watt
Start current	2 x 5.9A
Sound level	-

BioCompact II RR310/RF210 H

BioCompact II RR310/RF210 H - with solid door

Technical specifications	Data
Temperature range	RR310: +2/+20 °C RF210: -25/-5 °C
Ambient temperature range	RR310: +10/+35 °C RF210: +10/+35 °C
Software variant	RR310: K82 RF210: F52
K-Value	RR310: 0.355 W/(m ² *K) RF210: 0.3559 W/(m ² *K)
ATEX marking	II 3G Ex ec nC ic IIB T3 Gc
ATEX certificate	DTI 22ATEX0251X
Gross volume	RR310: 218 litres RF210: 125 litres
Net volume	RR310: 189 litres RF210: 104 litres
Dimensions – W x D x H	595 x 640 x 1991/2191 mm
Refrigerant	R134a
Refrigerant charge	RR310: 115 g RF210: 70 g
Refrigeration capacity at -10 °C	173 Watt
Refrigeration capacity at -25 °C	149 Watt
GWP – CO ₂ e	RR310: 164.45 RF210: 100.1
Energy consumption – default setpoint	RR310: 0.540 kWh/24h RF210: 1.584 kWh/24h
Heat emission 100 %	RR310: 137 Watt RF210: 148 Watt
Heat emission default setpoint	RR310: 22 Watt RF210: 66 Watt
Nominal consumption	RR310: 145 Watt RF210: 158.1 Watt
Start current	RR310: 8.6A RF210: 5.9A
Sound level	-

BioCompact II RR310/RF210 H - with glass door (RR)

Technical specifications	Data
Temperature range	RR310: +2/+20 °C RF210: -25/-5 °C
Ambient temperature range	RR310: +10/+32 °C RF210: +10/+35 °C
Software variant	RR310: K92 RF210: F52
K-Value	RR310: 0.50 W/(m ² *K) RF210: 0.3559 W/(m ² *K)
ATEX marking	II 3G Ex ec nC ic IIB T3 Gc
ATEX certificate	DTI 22ATEX0251X
Gross volume	RR310: 218 litres RF210: 125 litres
Net volume	RR310: 189 litres RF210: 104 litres
Dimensions – W x D x H	595 x 640 x 1991/2191 mm
Refrigerant	R134a
Refrigerant charge	RR310: 95 g RF210: 70 g
Refrigeration capacity at -10 °C	173 Watt
Refrigeration capacity at -25 °C	149 Watt
GWP – CO ₂ e	RR310: 135.85 RF210: 100.1
Energy consumption – default setpoint	RR310: N/A RF210: 1.584 kWh/24h
Heat emission 100 %	RR310: N/A RF210: 148 Watt
Heat emission default setpoint	RR310: N/A RF210: 158.1 Watt
Nominal consumption	RR310: 183 Watt RF210: 158.1 Watt
Start current	RR310: 9.7A RF210: 5.9A
Sound level	-

BioCompact II RR210 G

BioCompact II RR210 G - with solid door

Technical specifications	Data
Temperature range	+2/+20 °C
Ambient temperature range	+10/+35 °C
Software variant	K82
K-Value	0.3559 W/(m ² *K)
ATEX marking	II 3G Ex ec nC ic IIB T6 Gc
ATEX certificate	DTI 22ATEX0251X
Gross volume	125 litres
Net volume	104 litres
Dimensions – W x D x H	595 x 640 x 801/1001 mm
Refrigerant	R600a
Refrigerant charge	33 g
Refrigeration capacity at -10 °C	154 Watt
GWP – CO ₂ e	0.1089
Energy consumption – default setpoint	0.434 kWh/24h
Heat emission 100 %	97 Watt
Heat emission default setpoint	19 Watt
Nominal consumption	95 Watt
Start current	7.6A
Sound level	33.3 dB(A)

BioCompact II RR210 G - with glass door

Technical specifications	Data
Temperature range	+2/+20 °C
Ambient temperature range	+10/+32 °C
Software variant	K92
K-Value	0.5114 W/(m ² *K)
ATEX marking	II 3G Ex ec nC ic IIB T6 Gc
ATEX certificate	DTI 22ATEX0251X
Gross volume	125 litres
Net volume	104 litres
Dimensions – W x D x H	595 x 640 x 801/1001 mm
Refrigerant	R600a
Refrigerant charge	33 g
Refrigeration capacity at -10 °C	154 Watt
GWP – CO ₂ e	0.1089
Energy consumption – default setpoint	0.796 kWh/24h
Heat emission 100 %	101 Watt
Heat emission default setpoint	32 Watt
Nominal consumption	100 Watt
Start current	7.6A
Sound level	33.6 dB(A)

BioCompact II RR310 G

BioCompact II RR310 G - with solid door

Technical specifications	Data
Temperature range	+2/+20 °C
Ambient temperature range	+10/35 °C
Software variant	K82
K-Value	0.355 W/(m ² *K)
ATEX marking	II 3G Ex ec nC ic IIB T6 Gc
ATEX certificate	DTI 22ATEX0251X
Gross volume	218 litres
Net volume	189 litres
Dimensions – W x D x H	595 x 640 x 1190/1390 mm
Refrigerant	R600a
Refrigerant charge	45 g
Refrigeration capacity at -10 °C	154 Watt
GWP – CO ₂ e	0.1485
Energy consumption – default setpoint	0.519 kWh/24h
Heat emission 100 %	93 Watt
Heat emission default setpoint	20 Watt
Nominal consumption	95 Watt
Start current	7.6A
Sound level	34.1 dB(A)

BioCompact II RR310 G - with glass door

Technical specifications	Data
Temperature range	+2/+20 °C
Ambient temperature range	+10/+32 °C
Software variant	K92
K-Value	0.50 W/(m ² *K)
ATEX marking	II 3G Ex ec nC ic IIB T6 Gc
ATEX certificate	DTI 22ATEX0251X
Gross volume	218 litres
Net volume	189 litres
Dimensions – W x D x H	595 x 640 x 1190/1390 mm
Refrigerant	R600a
Refrigerant charge	45 g
Refrigeration capacity at -10 °C	154 Watt
GWP – CO ₂ e	0.1485
Energy consumption – default setpoint	0.907 kWh/24h
Heat emission 100 %	103 Watt
Heat emission default setpoint	36 Watt
Nominal consumption	101 Watt
Start current	7.6A
Sound level	35.2 dB(A)

BioCompact II RR410 G

BioCompact II RR410 G - with solid door

Technical specifications	Data
Temperature range	+2/+20 °C
Ambient temperature range	+10/+35 °C
Software variant	K82
K-Value	0.35 W/(m ² *K)
ATEX marking	3G Ex ec nC ic IIB T6 Gc
ATEX certificate	DTI 22ATEX0251X
Gross volume	346 litres
Net volume	312 litres
Dimensions – W x D x H	595 x 640 x 1776/1976 mm
Refrigerant	R600a
Refrigerant charge	60 g
Refrigeration capacity at -10 °C	207 Watt
GWP – CO ₂ e	0.198
Energy consumption – default setpoint	0.597 kWh/24h
Heat emission 100 %	106 Watt
Heat emission default setpoint	24 Watt
Nominal consumption	122 Watt
Start current	3.16A
Sound level	33.2 dB(A)

BioCompact II RR410 G - with glass door

Technical specifications	Data
Temperature range	+2/+20 °C
Ambient temperature range	+10/+32 °C
Software variant	K92
K-Value	0.5375 W/(m ² *K)
ATEX marking	3G Ex ec nC ic IIB T6 Gc
ATEX certificate	DTI 22ATEX0251X
Gross volume	346 litres
Net volume	312 litres
Dimensions – W x D x H	595 x 640 x 1776/1976 mm
Refrigerant	R600a
Refrigerant charge	51 g
Refrigeration capacity at -10 °C	312 Watt
GWP – CO ₂ e	0.1683
Energy consumption – default setpoint	1.319 kWh/24h
Heat emission 100 %	159 Watt
Heat emission default setpoint	52 Watt
Nominal consumption	156 Watt
Start current	17.2A
Sound level	33.7 dB(A)

BioCompact II RF210 G

BioCompact II RF310 G

BioCompact II RF210 G - with solid door

Technical specifications	Data
Temperature range	-25/-5 °C
Ambient temperature range	+10/+35 °C
Software variant	F52
K-Value	0.3559 W/(m ² *K)
ATEX marking	II 3G Ex ec nC ic IIB T3 Gc
ATEX certificate	DTI 22ATEX0251X
Gross volume	125 litres
Net volume	104 litres
Dimensions – W x D x H	595 x 640 x 801/1001 mm
Refrigerant	R600a
Refrigerant charge	43 g
Refrigeration capacity at -25 °C	159 Watt
GWP – CO ₂ e	0.1419
Energy consumption – default setpoint	1.476 kWh/24h
Heat emission 100 %	134 Watt
Heat emission default setpoint	57 Watt
Nominal consumption	132.8 Watt
Start current	17.2A
Sound level	37.7 dB(A)

BioCompact II RF310 G - with solid door

Technical specifications	Data
Temperature range	-25/-5 °C
Ambient temperature range	+10/+35 °C
Software variant	F52
K-Value	0.355 W/(m ² *K)
ATEX marking	3G Ex ec nC ic IIB T3 Gc
ATEX certificate	DTI 22ATEX0251X
Gross volume	218 litres
Net volume	189 litres
Dimensions – W x D x H	595 x 640 x 1190/1390 mm
Refrigerant	R600a
Refrigerant charge	35 g
Refrigeration capacity at -25 °C	204 Watt
GWP – CO ₂ e	0.1155
Energy consumption – default setpoint	1.565 kWh/24h
Heat emission 100 %	138 Watt
Heat emission default setpoint	63 Watt
Nominal consumption	143 Watt
Start current	8A
Sound level	37.8 dB(A)

BioCompact II RF410 G

BioCompact II RF410 G – with solid door

Technical specifications	Data
Temperature range	-25/-5 °C
Ambient temperature range	+10/+35 °C
Software variant	F52
K-Value	0.35 W/(m ² *K)
ATEX marking	II 3G Ex ec nC ic IIB T3 Gc
ATEX certificate	DTI 22ATEX0251X
Gross volume	346 litres
Net volume	312 litres
Dimensions – W x D x H	595 x 640 x 1776/1976 mm
Refrigerant	R600a
Refrigerant charge	47 g
Refrigeration capacity at -25 °C	204 Watt
GWP – CO ₂ e	0.1551
Energy consumption – default setpoint	2.068 kWh/24h
Heat emission 100 %	147.74 Watt
Heat emission default setpoint	80 Watt
Nominal consumption	154 Watt
Start current	8A
Sound level	36.6 dB(A)

BioCompact II RR210/RR210 G

BioCompact II RR210/RR210 G - with solid door

Technical specifications	Data
Temperature range	+2/+20 °C
Ambient temperature range	+10/+35 °C
Software variant	K82
K-Value	0.3559 W/(m ² *K)
ATEX marking	II 3G Ex nA nC nL IIB T3 Gc
ATEX certificate	DTI 22ATEX0251X
Gross volume	2 x 125 litres
Net volume	2 x 104 litres
Dimensions – W x D x H	595 x 640 x 1602/1802 mm
Refrigerant	R600a
Refrigerant charge	2 x 33 g
Refrigeration capacity at -10 °C	2 x 154 Watt
GWP – CO ₂ e	2 x 0.1089
Energy consumption – default setpoint	2 x 0.434 kWh/24h
Heat emission 100 %	2 x 97 Watt
Heat emission default setpoint	2 x 19 Watt
Nominal consumption	2 x 95 Watt
Start current	2 x 7.6A
Sound level	33.3 dB(A)

BioCompact II RR210/RR210 G - with glass door

Technical specifications	Data
Temperature range	+2/+20 °C
Ambient temperature range	+10/+32 °C
Software variant	K92
K-Value	0.5114 W/(m ² *K)
ATEX marking	II 3G Ex nA nC nL IIB T3 Gc
ATEX certificate	DTI 22ATEX0251X
Gross volume	2 x 125 litres
Net volume	2 x 104 litres
Dimensions – W x D x H	595 x 640 x 1602/1802 mm
Refrigerant	R600a
Refrigerant charge	66 g
Refrigeration capacity at -10 °C	2 x 154 Watt
GWP – CO ₂ e	2 x 0.1089
Energy consumption – default setpoint	2 x 0.796 kWh/24h
Heat emission 100 %	2 x 101 Watt
Heat emission default setpoint	2 x 32 Watt
Nominal consumption	2 x 100 Watt
Start current	2 x 7.6A
Sound level	33.5 dB(A)

BioCompact II RR210/RF210 G

BioCompact II RR210/RF210 G - with solid door

Technical specifications	Data
Temperature range	RR210: +2/+20 °C RF210: -25/-5 °C
Ambient temperature range	RR210: +10/+35 °C RF210: +10/+35 °C
Software variant	RR210: K82 RF210: F52
K-Value	RR210: 0.3559 W/(m ² *K) RF210: 0.3559 W/(m ² *K)
ATEX marking	II 3G Ex nA nC nL IIB T3 Gc
ATEX certificate	DTI 22ATEX0251X
Gross volume	2 x 125 litres
Net volume	2 x 104 litres
Dimensions – W x D x H	595 x 640 x 1602/1802 mm
Refrigerant	R600a
Refrigerant charge	RR210: 33 g RF210: 43 g
Refrigeration capacity at -10 °C	154 Watt
Refrigeration capacity at -25 °C	159 Watt
GWP – CO ₂ e	RR210: 0.1089 RF210: 0.1419
Energy consumption – default setpoint	RR210: 0.434 kWh/24h RF210: 1.476 kWh/24h
Heat emission 100 %	RR210: 97 Watt RF210: 134 Watt
Heat emission default setpoint	RR210: 19 Watt RF210: 57 Watt
Nominal consumption	RR210: 95 Watt RF210: 132.8 Watt
Start current	RR210: 7.6A RF210: 17.2A
Sound level	36.1 dB(A)

BioCompact II RR210/RF210 G - with glass door (RR)

Technical specifications	Data
Temperature range	RR210: +2/+20 °C RF210: -25/-5 °C
Ambient temperature range	RR210: +10/+32 °C RF210: +10/+35 °C
Software variant	RR210: K92 RF210: F52
K-Value	RR210: 0.5114 W/(m ² *K) RF210: 0.3559 W/(m ² *K)
ATEX marking	II 3G Ex nA nC nL IIB T3 Gc
ATEX certificate	DTI 22ATEX0251X
Gross volume	2 x 125 litres
Net volume	2 x 104 litres
Dimensions – W x D x H	595 x 640 x 1602/1802 mm
Refrigerant	R600a
Refrigerant charge	RR210: 33 g RF210: 43 g
Refrigeration capacity at -10 °C	154 Watt
Refrigeration capacity at -25 °C	159 Watt
GWP – CO ₂ e	RR210: 0.1089 RF210: 0.1419
Energy consumption – default setpoint	RR210: 0.796 kWh/24h RF210: 1.476 kWh/24h
Heat emission 100 %	RR210: 101 Watt RF210: 134 Watt
Heat emission default setpoint	RR210: 32 Watt RF210: 57 Watt
Nominal consumption	RR210: 100 Watt RF210: 132.8 Watt
Start current	RR210: 7.6A RF210: 17.2A
Sound level	36.1 dB(A)

BioCompact II RF210/RF210 G

BioCompact II RF210/RF210 G - with solid door

Technical specifications	Data
Temperature range	-25/-5 °C
Ambient temperature range	+10/+35 °C
Software variant	F52
K-Value	0.3559 W/(m ² *K)
ATEX marking	II 3G Ex nA nC nL IIB T3 Gc
ATEX certificate	DTI 22ATEX0251X
Gross volume	2 x 125 litres
Net volume	2 x 104 litres
Dimensions – W x D x H	595 x 640 x 1602/1802 mm
Refrigerant	R600a
Refrigerant charge	2 x 43 g
Refrigeration capacity at -25 °C	2 x 159 Watt
GWP – CO ₂ e	0.1419
Energy consumption – default setpoint	2 x 1.476 kWh/24h
Heat emission 100 %	2 x 134 Watt
Heat emission default setpoint	2 x 57 Watt
Nominal consumption	2 x 132.8 Watt
Start current	2 x 17.2A
Sound level	37.7 dB(A)

BioCompact II RR310/RF210 G

BioCompact II RR310/RF210 G - with solid door

Technical specifications	Data
Temperature range	RR310: +2/+20 °C RF210: -25/-5 °C
Ambient temperature range	RR210: +10/+35 °C RF210: +10/+35 °C
Software variant	K82/F52
K-Value	RR310: 0.355 W/(m ² *K) RF210: 0.3559 W/(m ² *K)
ATEX marking	II 3G Ex ec nC ic IIB T3 Gc
ATEX certificate	DTI 22ATEX0251X
Gross volume	RR310: 218 litres RF210: 125 litres
Net volume	RR310: 189 litres RF210: 104 litres
Dimensions – W x D x H	595 x 640 x 1991/2191 mm
Refrigerant	R600a
Refrigerant charge	RR310: 45 g RF210: 43 g
Refrigeration capacity at -10 °C	154 Watt
Refrigeration capacity at -25 °C	159 Watt
GWP – CO ₂ e	RR310: 0.1485 RF210: 0.1419
Energy consumption – default setpoint	RR310: 0.519 kWh/24h RF210: 1.476 kWh/24h
Heat emission 100 %	RR310: 93 Watt RF210: 134 Watt
Heat emission default setpoint	RR310: 20 Watt RF210: 57 Watt
Nominal consumption	RR310: 95 Watt RF210: 132.8 Watt
Start current	RR310: 7.6A RF210: 17.2A
Sound level	36.3 dB(A)

BioCompact II RR310/RF210 G - with glass door (RR)

Technical specifications	Data
Temperature range	RR310: +2/+20 °C RF210: -25/-5 °C
Ambient temperature range	RR210: +10/+32 °C RF210: +10/+35 °C
Software variant	RR310: K92 RF210: F52
K-Value	RR310: 0.50 W/(m ² *K) RF210: 0.3559 W/(m ² *K)
ATEX marking	II 3G Ex ec nC ic IIB T3 Gc
ATEX certificate	DTI 22ATEX0251X
Gross volume	RR310: 218 litres RF210: 125 litres
Net volume	RR310: 189 litres RF210: 104 litres
Dimensions – W x D x H	595 x 640 x 1991/2191 mm
Refrigerant	R600a
Refrigerant charge	RR310: 45 g RF210: 43 g
Refrigeration capacity at -10 °C	154 Watt
Refrigeration capacity at -25 °C	159 Watt
GWP – CO ₂ e	RR310: 0.1485 RF210: 0.1419
Energy consumption – default setpoint	RR310: 0.907 kWh/24h RF210: 1.476 kWh/24h
Heat emission 100 %	RR310: 103 Watt RF210: 134 Watt
Heat emission default setpoint	RR310: 36 Watt RF210: 57 Watt
Nominal consumption	RR310: 101 Watt RF210: 132.8 Watt
Start current	RR310: 7.6A RF210: 17.2A
Sound level	36.6 dB(A)

BioCompact II RR610

General data: BioCompact II 610

Technical specifications	Data
Connection	230 VAC, 50 Hz
Control Unit	Gram Control Unit with voltage-free contact, alarms and offset function
Alarms	Acoustic and visual, High/Low-temperature alarms and door alarm
Alarm ports	Voltage-free contact
Access port	1 pc. ø24.5 mm
Door	Right or left hinged
Material interior	PS lining with wall rails in stainless steel
Material exterior	White lacquered steel or stainless steel finish
Insulation	60 mm polyurethane with HFC-free cyclopentane propellant
Gross volume	583 litres
Net volume	419 litres
Air system	BioLine ventilated air distribution system
Defrost system	Automatic smart defrost with re-evaporation of defrost water
IP class	IP21

BioCompact II RR610 H

BioCompact II RR610 H – with solid door

Technical specifications	Data
Temperature range	+2/+20 °C
Ambient temperature range	+10/+43 °C
Software variant	K2+
K-Value	0.31 W/(m ² *K)
ATEX marking	II 3G Ex nA nC nL IIB T6 Gc
ATEX certificate	–
Dimensions – W x D x H	695 x 875 x 1874/2075 mm
Refrigerant	R134a
Refrigerant charge	230 g
Refrigeration capacity at -10 °C	314 Watt
GWP – CO ₂ e	328.9
Energy consumption – default setpoint	1.36 kWh/24h
Heat emission 100 %	322 Watt
Heat emission default setpoint	56 Watt
Nominal consumption	314 Watt
Start current	11.4A
Sound level	45.3 dB(A)

BioCompact II RR610 H – with glass door

Technical specifications	Data
Temperature range	+2/+20 °C
Ambient temperature range	+10/+38 °C
Software variant	K6+
K-Value	0.4819 W/(m ² *K)
ATEX marking	II 3G Ex nA nC nL IIB T6 Gc
ATEX certificate	–
Dimensions – W x D x H	695 x 875 x 1874/2075 mm
Refrigerant	R134a
Refrigerant charge	230 g
Refrigeration capacity at -10 °C	314 Watt
GWP – CO ₂ e	328.9
Energy consumption – default setpoint	2.02 kWh/24h
Heat emission 100 %	334 Watt
Heat emission default setpoint	84 Watt
Nominal consumption	329 Watt
Start current	11.4A
Sound level	–

BioCompact II RF610 H

BioCompact II RF610 H – with solid door

Technical specifications	Data
Temperature range	-25/-5 °C
Ambient temperature range	+10/+43 °C
Software variant	F51
K-Value	0.31 W/(m ² *K)
ATEX marking	II 3G Ex nA nC nL IIB T2 Gc
ATEX certificate	–
Dimensions – W x D x H	695 x 875 x 1874/2075 mm
Refrigerant	R404a
Refrigerant charge	220 g
Refrigeration capacity at -25 °C	616 Watt
GWP – CO ₂ e	862.85
Energy consumption – default setpoint	4.2 kWh/24h
Heat emission 100 %	583 Watt
Heat emission default setpoint	175 Watt
Nominal consumption	613 Watt
Start current	19.6A
Sound level	47.9 dB(A)

BioCompact II RR610 G

BioCompact II RR610 G - with solid door

Technical specifications	Data
Temperature range	+2/+20 °C
Ambient temperature range	+10/+43 °C
Software variant	K2+
K-Value	0.31 W/(m ² *K)
ATEX marking	II 3G Ex nA nC nL IIB T6 Gc
ATEX certificate	-
Dimensions - W x D x H	695 x 875 x 1874/2075 mm
Refrigerant	R600a
Refrigerant charge	102 g
Refrigeration capacity at -10 °C	354 Watt
GWP - CO ₂ e	0.3366
Energy consumption - default setpoint	1.15 kWh/24h
Heat emission 100 %	270 Watt
Heat emission default setpoint	48 Watt
Nominal consumption	291 Watt
Start current	9.3A
Sound level	44.2 dB(A)

BioCompact II RR610 G - with glass door

Technical specifications	Data
Temperature range	+2/+20 °C
Ambient temperature range	+10/+38 °C
Software variant	K6+
K-Value	0.4819 W/(m ² *K)
ATEX marking	II 3G Ex nA nC nL IIB T6 Gc
ATEX certificate	-
Dimensions - W x D x H	695 x 875 x 1874/2075 mm
Refrigerant	R600a
Refrigerant charge	102 g
Refrigeration capacity at -10 °C	422 Watt
GWP - CO ₂ e	N/A
Energy consumption - default setpoint	1.9 kWh/24h
Heat emission 100 %	305 Watt
Heat emission default setpoint	79 Watt
Nominal consumption	315 Watt
Start current	8A
Sound level	-

BioCompact II RF610 G

BioCompact II RF610 G – with solid door

Technical specifications	Data
Temperature range	-25/-5 °C
Ambient temperature range	+10/+43 °C
Software variant	F51
K-Value	0.31 W/(m ² *K)
ATEX marking	II 3G Ex nA nC nL IIB T2 Gc
ATEX certificate	–
Dimensions – W x D x H	695 x 875 x 1874/2075 mm
Refrigerant	R290
Refrigerant charge	92 g
Refrigeration capacity at -25 °C	512 Watt
GWP – CO ₂ e	0.3036
Energy consumption – default setpoint	4.05 kWh/24h
Heat emission 100 %	472 Watt
Heat emission default setpoint	162 Watt
Nominal consumption	485 Watt
Start current	13.1A
Sound level	48.6 dB(A)

Declaration of conformity

BioCompact II 210, 310, 410, 210/210 & 310/210



English EC Declaration of Conformity

We, **Gram Scientific ApS**, declare as manufacturer under sole responsibility that the following products comply with all relevant regulations:

Range:	BioCompact II
Model:	RR210, RF210, RR310, RF310, RR410, RF410, RR210/RF210 & RR310/RF210
Refrigeration:	R600a & R134a
Product description:	Refrigerators and freezer for laboratory and biostorage
Valid from (Year/Week):	2023/01

This declaration pertains to compliance with all applicable essential requirements and other provisions of the European Council Directive and regulations. Specifically, the following Directives and Regulations of the European Parliament and of the Council apply:

Directives and Regulations of the European Parliament and of the Council:

- Machinery Directive 2006/42/EC
- ATEX Directive 2014/34/EU
- Pressure Equipment Directive 2014/68/EU
- Low Voltage Directive 2014/35/EU
- EMC Directive 2014/30/EU
- RoHS Directive 2011/65/EU
- REACH EC No.1907/2006
- F-Gas Regulation (EU) No 2024/573

Product compliance has been demonstrated based on the following harmonized standards:

Harmonized Standards:	Text:
EN 60601-1:2006	Medical electrical equipment – Part 1: General requirements for basic safety and essential performance
EN 60601-1-2:2015	Medical electrical equipment – Part 1-2: General requirements for basic safety and essential performance – Collateral Standard: Electromagnetic disturbances – Requirements and tests
EN 61010-1:2010	Safety requirements for electrical equipment for measurement, control, and laboratory use - Part 1: General requirements
EN 61326-1:2013	Electrical equipment for measurement, control and laboratory use – EMC requirements – Part 1: General requirements
EN IEC 61000-3-2:2019	Electromagnetic compatibility (EMC) – Part 3-2: Limits – Limits for harmonic current emissions (equipment input current ≤16 A per phase)
EN 61000-3-3:2013	Electromagnetic compatibility (EMC) – Part 3-3: Limits – Limitation of voltage changes, voltage fluctuations and flicker in public low-voltage supply systems, for equipment with rated current ≤ 16 A per phase and not subject to conditional connection
EN IEC 60079-0:2018 EN IEC 60079-0:2018/AC:2020	Explosive atmospheres – Part 0: Equipment – General requirements
EN 60079-7:2015 EN 60079-7:2015/A1:2018	Explosive atmospheres – Part 7: Equipment protection by increased safety "e"
EN 60079-11:2012	Explosive atmospheres – Part 11: Equipment protection by intrinsic safety "i"
EN IEC 60079-15:2019	Explosive atmospheres – Part 15: Equipment protection by type of protection "n"
EN 60079-18:2015	Explosive atmospheres – Part 18: Equipment protection by encapsulation "m"
EN ISO 3744:2010	Acoustics – Determination of sound power levels and sound energy levels of noise sources using sound pressure – Engineering methods for an essentially free field over a reflecting plane
EN ISO 9001:2015	Quality management systems – Requirements
EN ISO 14001:2015	Environmental management systems – Requirements with guidance for use

Gram Scientific ApS
 Aage Grams Vej 1
 DK-6500 Vojsens
 Denmark
 Telephone: + 45 73 20 13 00

Vojsens, 20.03.2024

John B. S. Petersen
 Approval Manager

Rev. 007 – 20.03.2024

BioCompact II 610



English EC Declaration of Conformity

We, **Gram Scientific ApS**, declare as manufacturer under sole responsibility that the following products comply with all relevant regulations:

Range:	BioCompact II
Model:	RR610 & RF610
Refrigeration:	R600a, R290, R404A & R134a
Product description:	Refrigerators and freezer for laboratory and biostorage
Valid from (Year/Week):	2023/01

This declaration pertains to compliance with all applicable essential requirements and other provisions of the European Council Directive and regulations. Specifically, the following Directives and Regulations of the European Parliament and of the Council apply:

Directives and Regulations of the European Parliament and of the Council:	
Machinery Directive 2006/42/EC	
- ATEX Directive 2014/34/EU	
- Pressure Equipment Directive 2014/68/EU	
- Low Voltage Directive 2014/35/EU	
- EMC Directive 2014/30/EU	
- RoHS Directive 2011/65/EU	
- REACH EC No.1907/2006	
- F-Gas Regulation (EU) No 2024/573	

Product compliance has been demonstrated based on the following harmonized standards:

Harmonized Standards:	Text:
EN 61010-1:2010	Safety requirements for electrical equipment for measurement, control, and laboratory use – Part 1: General requirements
EN 60601-1:2006	Medical electrical equipment. General requirements for basic safety and essential performance
EN 60601-1-2:2015	Medical electrical equipment – Part 1-2: General requirements for basic safety and essential performance - Collateral standard: Electromagnetic compatibility - Requirements and tests
EN 60079-0:2012	Electrical apparatus for explosive atmospheres – Part 0: General requirements
EN 60079-11:2012	Explosive atmospheres – Part 11: Equipment protection by intrinsic safety "i"
EN 60079-15:2010	Explosive atmospheres – Part 15: Equipment protection by type of protection "n"
EN 60079-25:2010	Explosive atmospheres – Part 25: Intrinsically safe systems
EN ISO 3744:2010	Acoustics – Determination of sound power levels of noise sources using sound pressure - Engineering method in an essentially free field over a reflecting plane
EN ISO 9001:2015	Quality management systems
EN ISO 14001:2015	Environment management systems – Requirements with guidance for use

Gram Scientific ApS
 Aage Grams Vej 1
 DK-6500 Vojens
 Denmark
 Telephone: + 45 73 20 13 00

Vojens, 20.03.2024



John B. S. Petersen
 Approval Manager

BioCompact II 210, 310, 410, 210/210 & 310/210 – Accessories code 69



English EC Declaration of Conformity

We, **Gram Scientific ApS**, declare as manufacturer under sole responsibility that the following products comply with all relevant regulations:

Range:	BioCompact II (Accessorie code 69)
Model:	RR210, RF210, RR310, RF310, RR410, RF410, RR210/RF210 & RR310/RF210
Refrigeration:	R600a & R134a
Product description:	Refrigerators and freezer for laboratory and biostorage
Valid from (Year/Week):	2024/01

This declaration pertains to compliance with all applicable essential requirements and other provisions of the European Council Directive and regulations. Specifically, the following Directives and Regulations of the European Parliament and of the Council apply:

Directives and Regulations of the European Parliament and of the Council:

Machinery Directive 2006/42/EC
 - Pressure Equipment Directive 2014/68/EU
 - Low Voltage Directive 2014/35/EU
 - EMC Directive 2014/30/EU
 - RoHS Directive 2011/65/EU
 - REACH EC No.1907/2006
 - F-Gas Regulation (EU) No 2024/573

Product compliance has been demonstrated based on the following harmonized standards:

Harmonized Standards:	Text:
EN 60601-1:2006	Medical electrical equipment – Part 1: General requirements for basic safety and essential performance
EN 60601-1-2:2015	Medical electrical equipment – Part 1-2: General requirements for basic safety and essential performance – Collateral Standard: Electromagnetic disturbances – Requirements and tests
EN 61010-1:2010	Safety requirements for electrical equipment for measurement, control, and laboratory use - Part 1: General requirements
EN 61326-1:2013	Electrical equipment for measurement, control and laboratory use – EMC requirements – Part 1: General requirements
EN IEC 61000-3-2:2019	Electromagnetic compatibility (EMC) – Part 3-2: Limits – Limits for harmonic current emissions (equipment input current ≤16 A per phase)
EN 61000-3-3:2013	Electromagnetic compatibility (EMC) – Part 3-3: Limits – Limitation of voltage changes, voltage fluctuations and flicker in public low-voltage supply systems, for equipment with rated current ≤ 16 A per phase and not subject to conditional connection
DIN 13277:2022-05	Refrigerators and freezers for laboratory and medical applications – Terminology, requirements, testing
EN ISO 3744:2010	Acoustics – Determination of sound power levels and sound energy levels of noise sources using sound pressure – Engineering methods for an essentially free field over a reflecting plane
EN ISO 9001:2015	Quality management systems – Requirements
EN ISO 14001:2015	Environmental management systems – Requirements with guidance for use

Gram Scientific ApS
 Aage Grams Vej 1
 DK-6500 Vojens
 Denmark
 Telephone: + 45 73 20 13 00

Vojens, 15.05.2024

John B. S. Petersen
 Approval Manager

BioCompact II 610 – Accessories code 69



English EC Declaration of Conformity

We, **Gram Scientific ApS**, declare as manufacturer under sole responsibility that the following products comply with all relevant regulations:

Range:	BioCompact II (Accessorie code 69)
Model:	RR610 & RF610
Refrigeration:	R600a, R290, R404A & R134a
Product description:	Refrigerators and freezer for laboratory and biostorage
Valid from (Year/Week):	2024/01

This declaration pertains to compliance with all applicable essential requirements and other provisions of the European Council Directive and regulations. Specifically, the following Directives and Regulations of the European Parliament and of the Council apply:

Directives and Regulations of the European Parliament and of the Council:
Machinery Directive 2006/42/EC
- Pressure Equipment Directive 2014/68/EU
- Low Voltage Directive 2014/35/EU
- EMC Directive 2014/30/EU
- RoHS Directive 2011/65/EU
- REACH EC No. 1907/2006
- F-Gas Regulation (EU) No 2024/573

Product compliance has been demonstrated based on the following harmonized standards:	
Harmonized Standards:	Text:
EN 61010-1:2010	Safety requirements for electrical equipment for measurement, control, and laboratory use – Part 1: General requirements
EN 60601-1:2006	Medical electrical equipment. General requirements for basic safety and essential performance
EN 60601-1-2:2015	Medical electrical equipment – Part 1-2: General requirements for basic safety and essential performance - Collateral standard: Electromagnetic compatibility - Requirements and tests
DIN 13277:2022-05	Refrigerators and freezers for laboratory and medical applications – Terminology, requirements, testing
EN ISO 3744:2010	Acoustics – Determination of sound power levels of noise sources using sound pressure - Engineering method in an essentially free field over a reflecting plane
EN ISO 9001:2015	Quality management systems
EN ISO 14001:2015	Environment management systems – Requirements with guidance for use

Gram Scientific ApS
 Aage Grams Vej 1
 DK-6500 Vojens
 Denmark
 Telephone: + 45 73 20 13 00

Vojens, 15.05.2024



John B. S. Petersen
 Approval Manager

Wiring diagram

BioCompact II 210, 310, 410

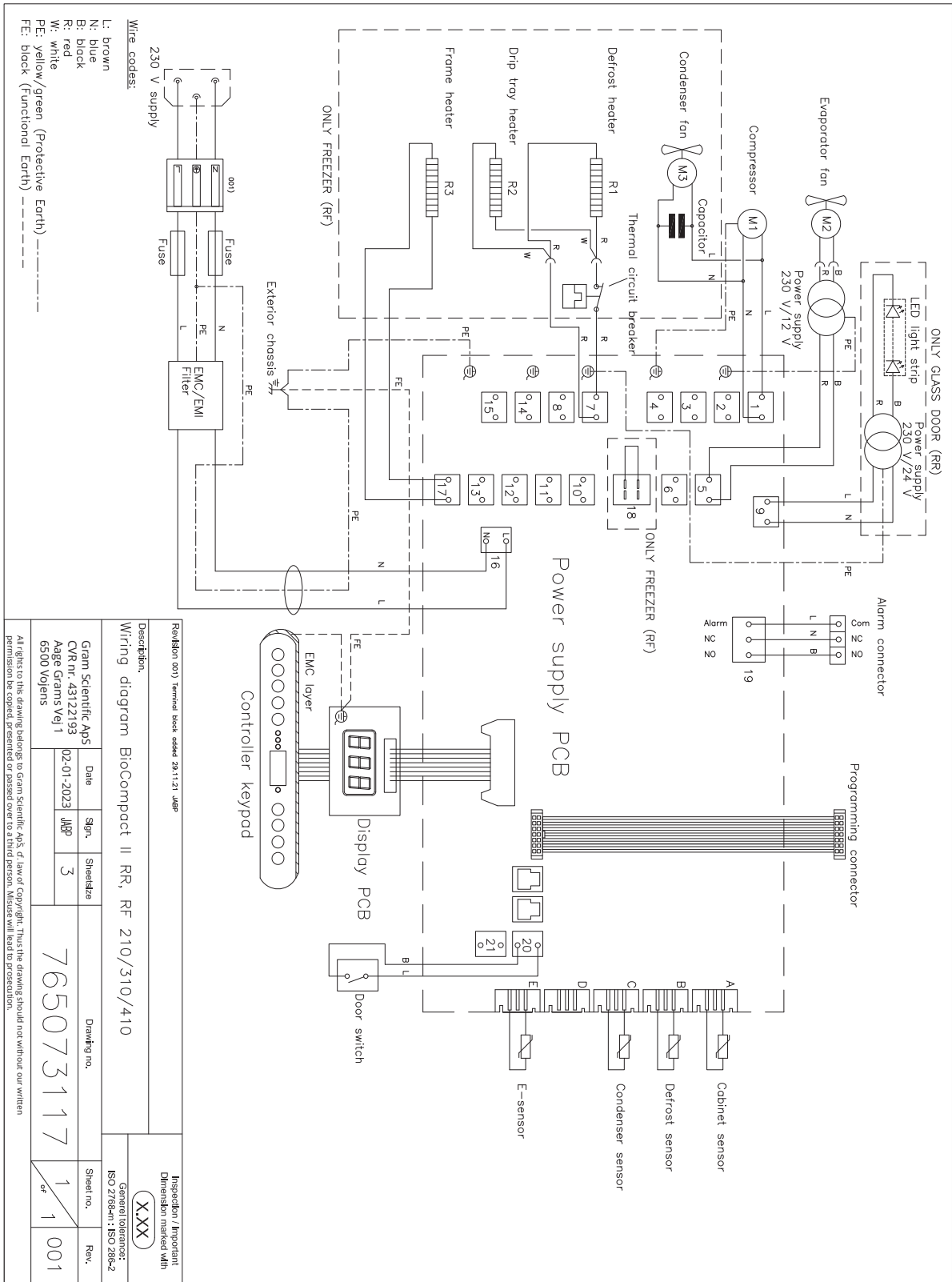

BioCompact II 210, 310, 410 – With LTP

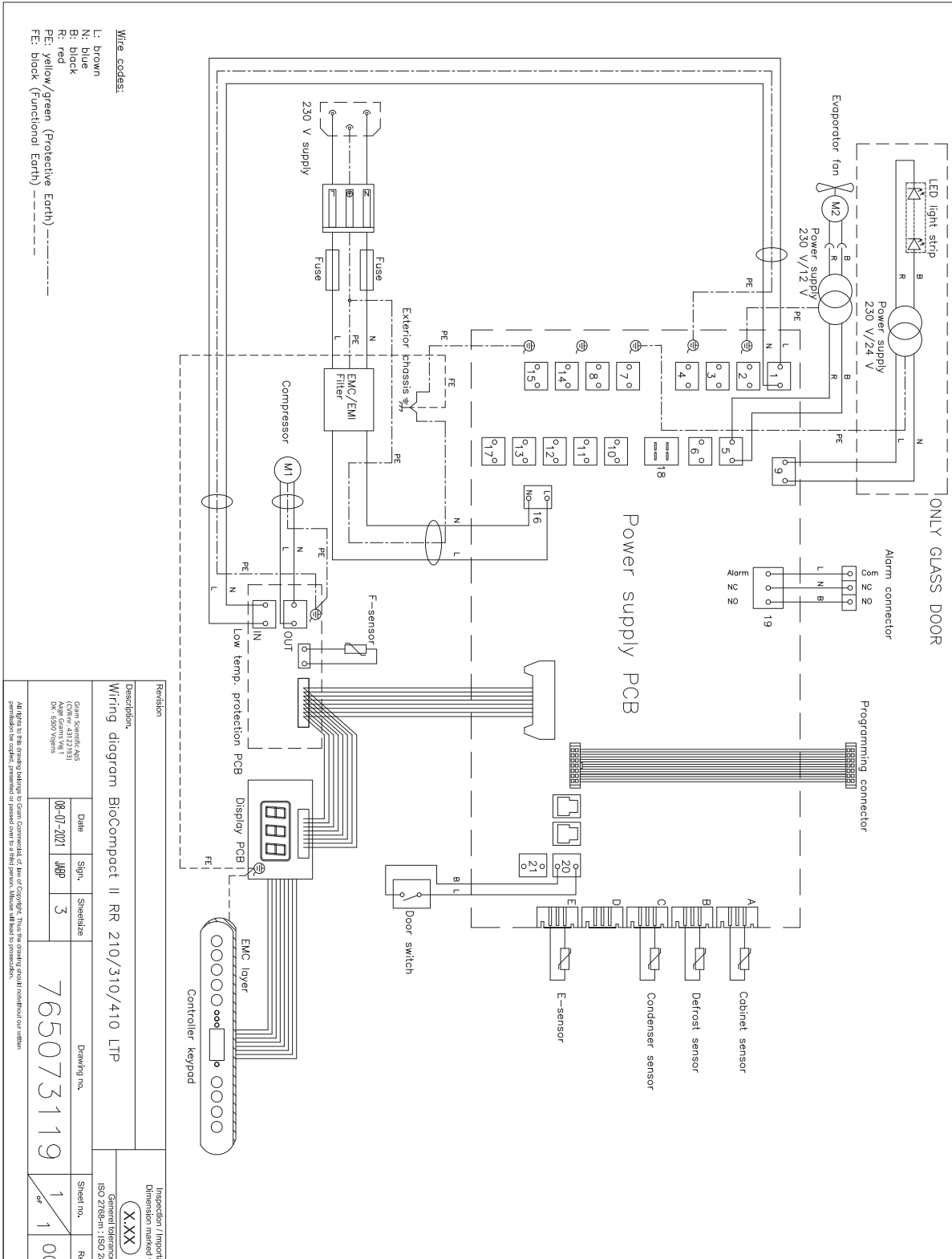

BioCompact II RR610 - With solid door

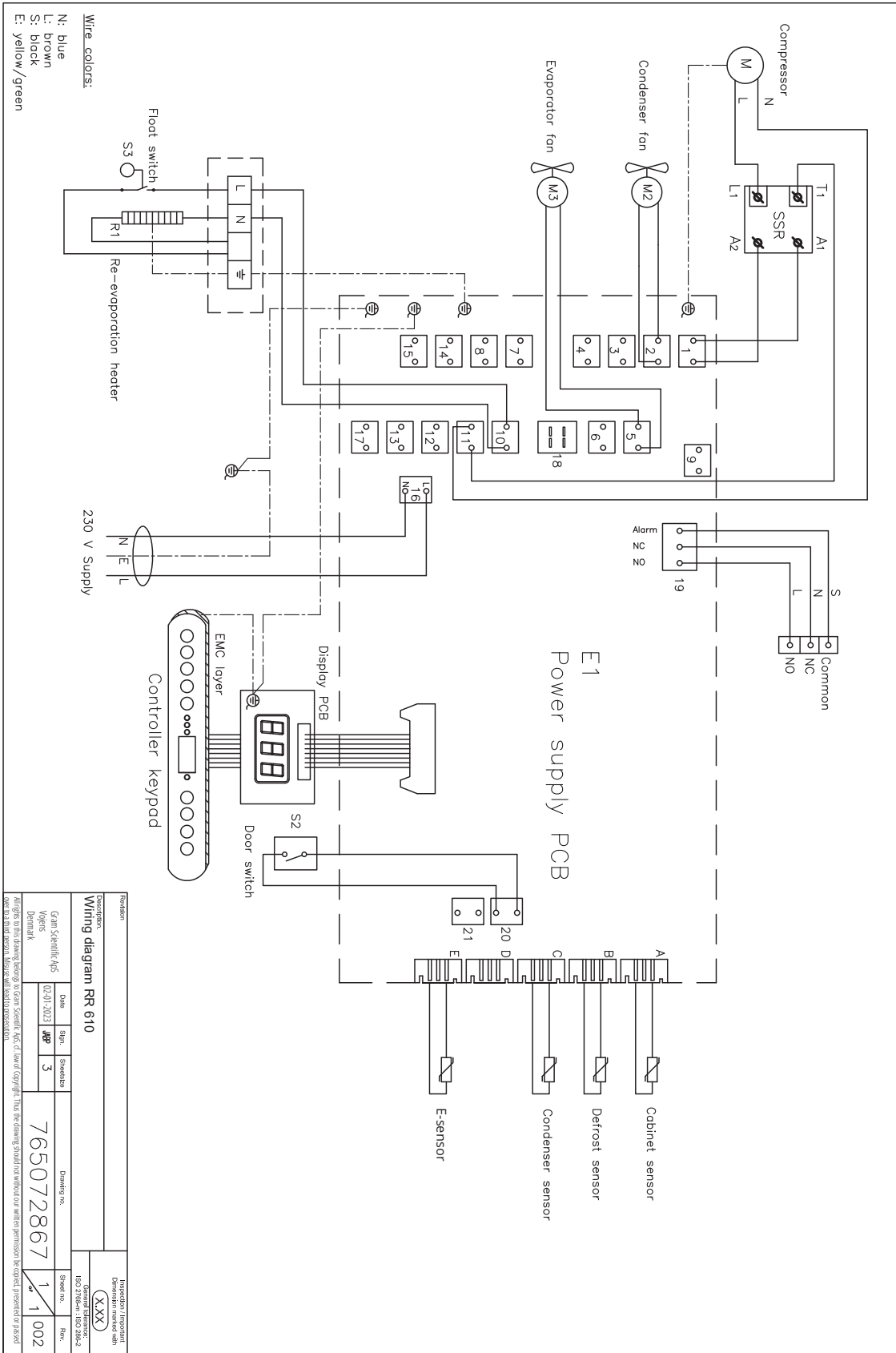

Revision		Inspection / Approval	
Description: Wiring diagram RR 610		Drawing no. 765072867	
Author: Gørn Sørensen	Date: 02.01.2023	Spec. no.:	Rev. no.:
Version: 1	Drawn: 3	Spec. no.:	Rev. no.:
Drawing no. 765072867		Rev. no. 002	
Drawing no. 765072867		Rev. no. 002	

Copyright © 2023 by Gørn Sørensen. All rights reserved. This document is confidential and its disclosure without prior permission is prohibited. Reproduction or distribution of this document is prohibited.

BioCompact II RF610

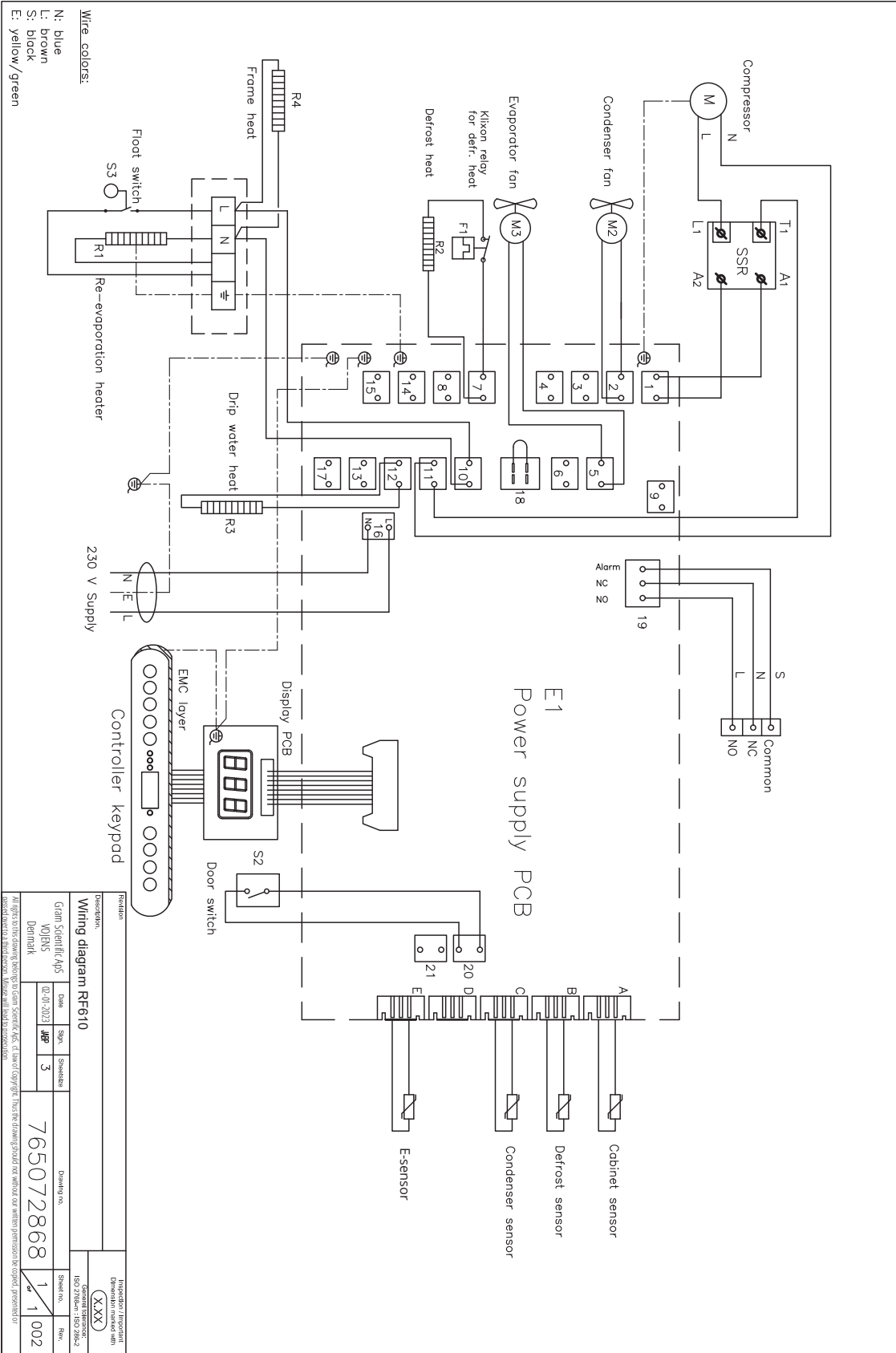

BioCompact II RR610 - With glass door

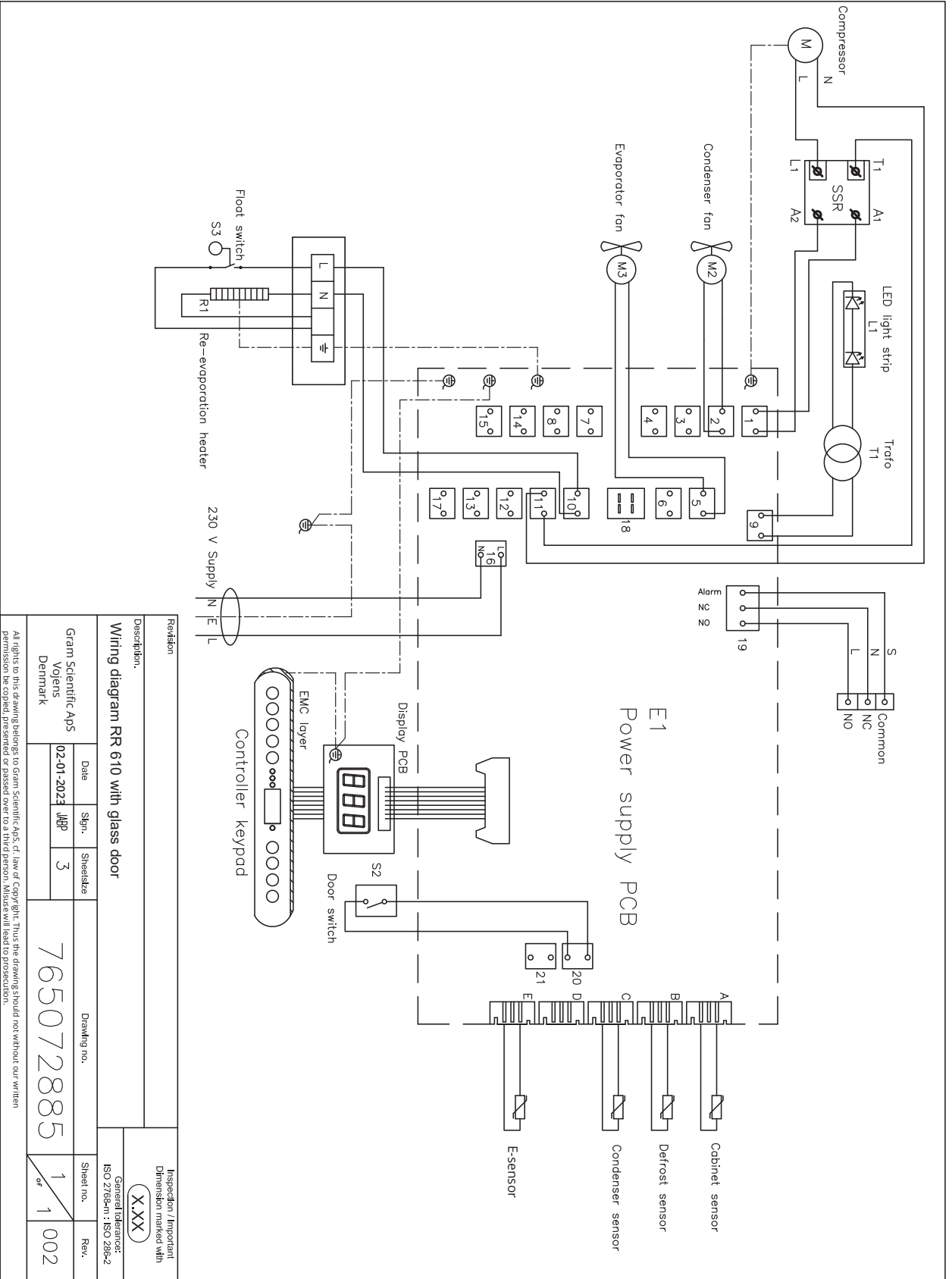

BioCompact II RR610 - With solid door, with LTP

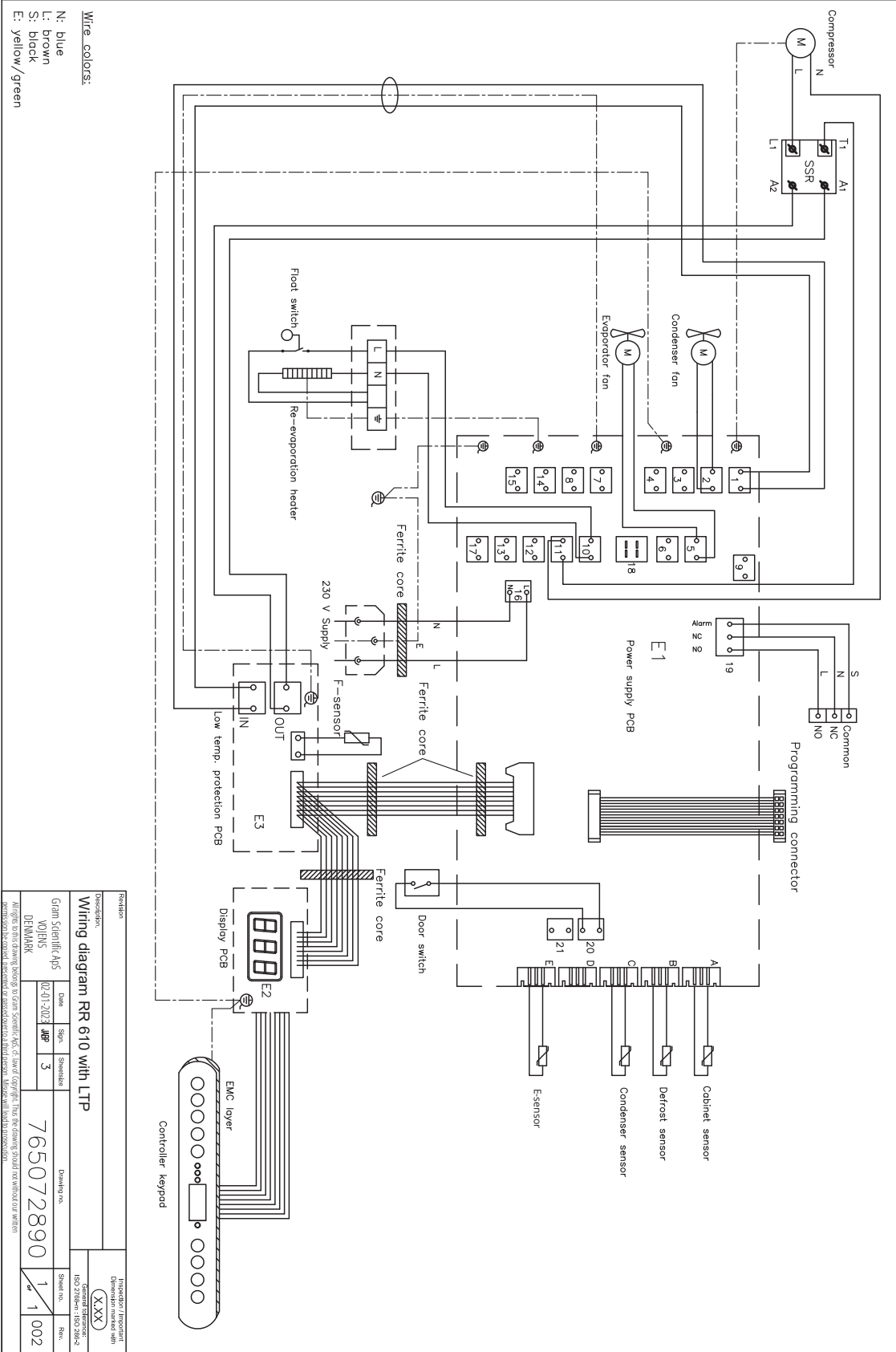

BioCompact II RR610 - With glass door, with LTP

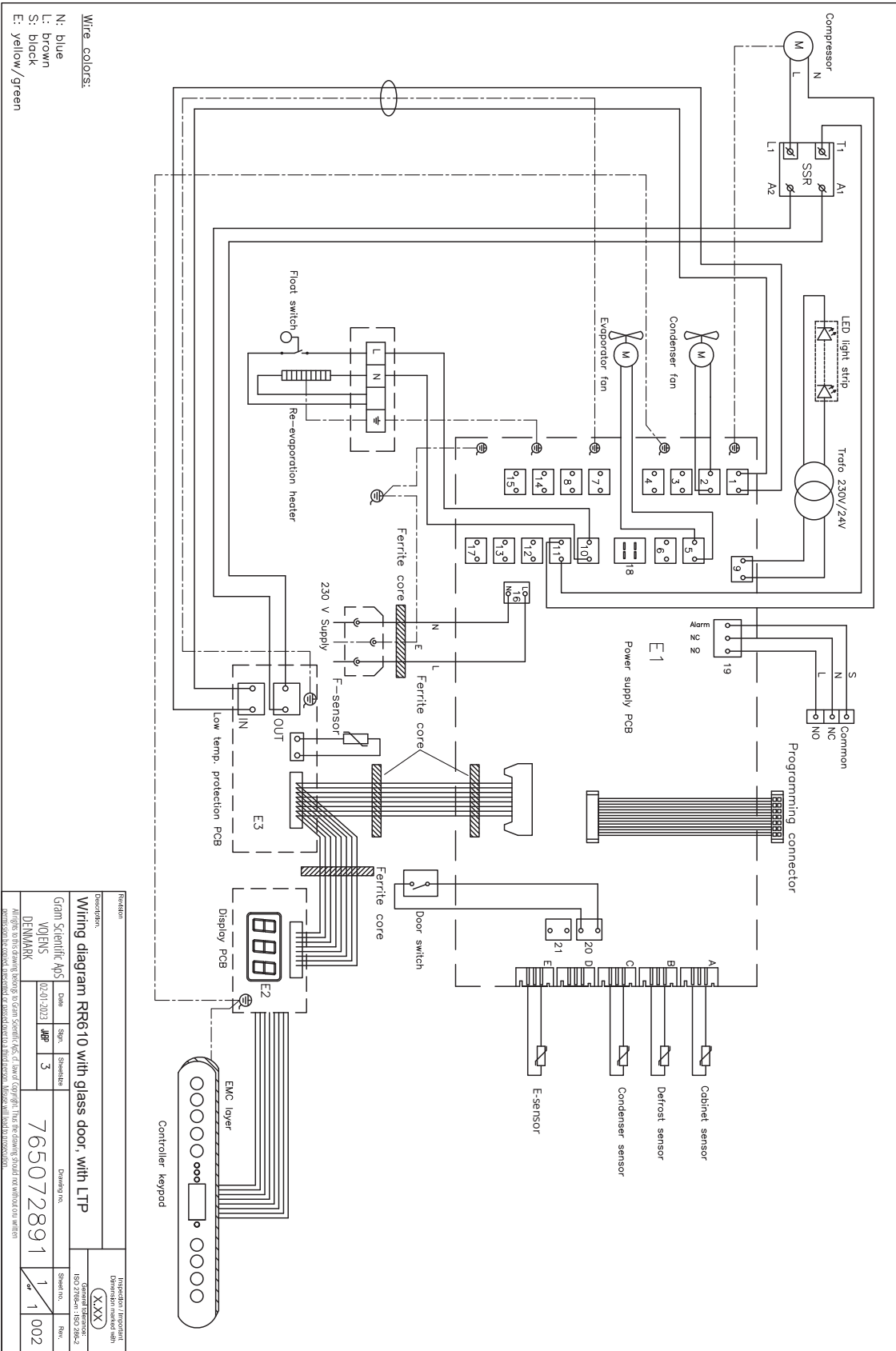

BioCompact II

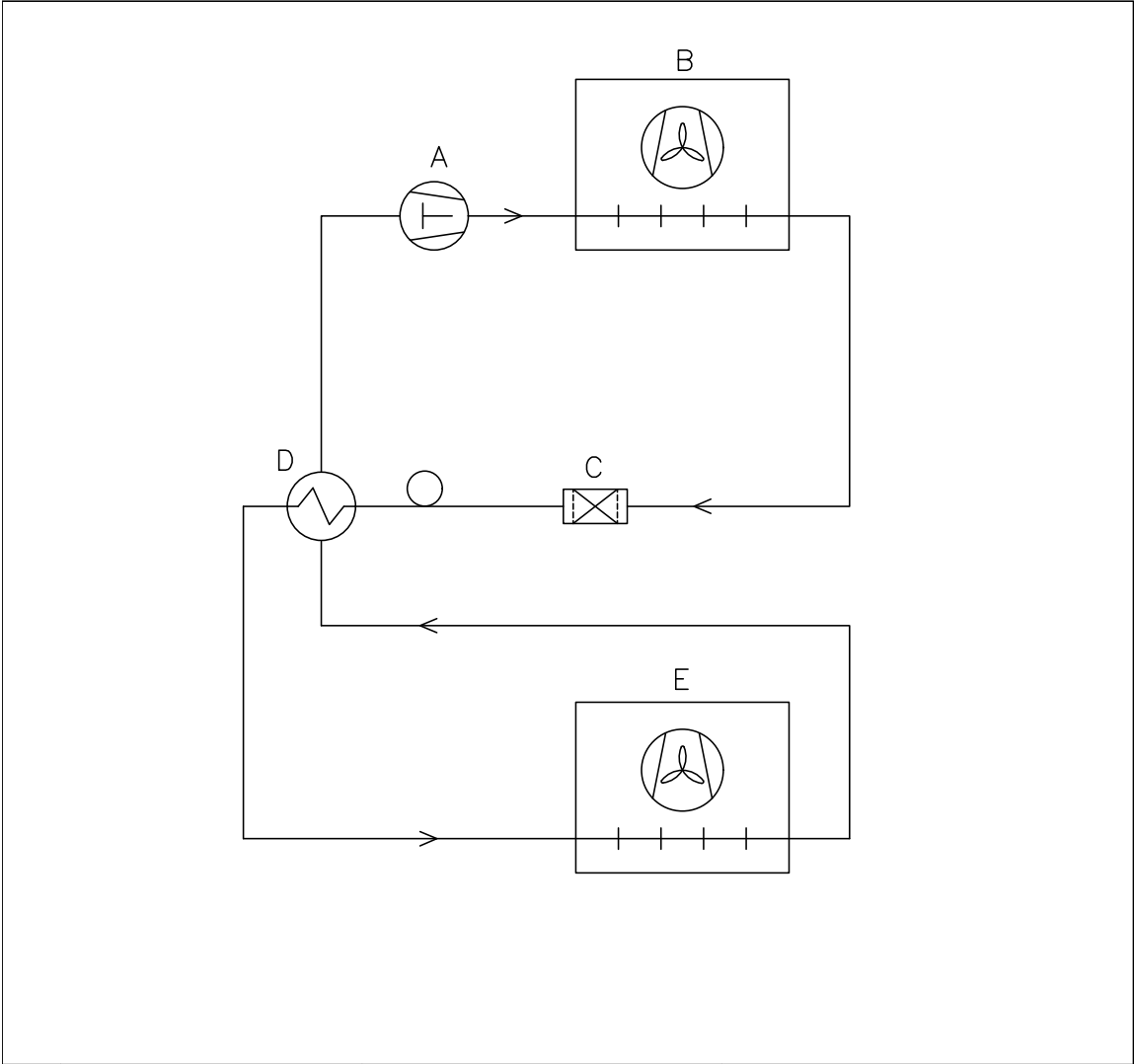

	DK	GB	D
A	Kompressor	Compressor	Kompressor
B	Kondensator	Condenser	Verflüssiger
C	Tørrefilter	Filter drier	Trockenfilter
D	Varmeudveksler	Heat exchanger	Wärmeaustauscher
E	Fordamper	Evaporator	Verdampfer

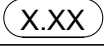
Revision		Inspection / important Dimension marked with 
Description. Piping diagram BioCompact II		
		General tolerance: ISO 2768-m : ISO 286-2

Gram Scientific ApS (CVR-nr. 43122193) Aage Grams Vej 1 6500 Vojens	Date	Sign.	Sheetsize	Drawing no.	Sheet no.	Rev.
		02-01-2023	JABP	4	765042593	1 of 1

All rights to this drawing belongs to Gram Scientific ApS, cf. law of copyright. Thus the drawing should not without our written permission be copied, presented or passed over to a third person. Misuse will lead to prosecution.

General maintenance information

- Implement a cleaning routine.
- Cleaning tasks should be documented and kept record of.
- Check the temperature of your refrigerator/freezer regularly.
- When storing valuable or temperature-sensitive materials or products, it is advisable to employ a continuously monitoring autonomous alarm system. This alarm system should be designed in a manner that allows authorised individuals to promptly detect each alarm state and take the necessary corrective actions.

- WARNING -

Maintenance work should only be performed by a Gram BioLine authorised technician.



Make sure that the refrigerator/freezer is switched off at the socket before any maintenance work is performed. Transfer all contents to another refrigerator or freezer under safe and regulated conditions.

Maintenance plan

The following maintenance plan represents a generic schedule for maintenance. Use and/or conditions may impact the required frequency of the subsequent points.

Component	Task	Frequency
Base	<ul style="list-style-type: none"> Ensure cabinets with legs are levelled properly and cabinets with castors are placed on a level surface and locked. 	Yearly
Interior fittings	<ul style="list-style-type: none"> Ensure that all interior fittings are fixed correctly. 	Yearly
Door gasket	<ul style="list-style-type: none"> Ensure that the gasket is pliable and in good working order. Ensure that the door is aligned with the door frame and fits tightly when closed. 	Yearly
Condenser and fan	<ul style="list-style-type: none"> Ensure it is not dented or shows any other signs of damage and does not make any abnormal noises. 	Yearly
Keypad	<ul style="list-style-type: none"> Ensure it is not dented or shows any other signs of damage. 	Yearly
Ice build-up	<ul style="list-style-type: none"> Ensure ice accumulation does not hinder operation or performance. 	Monthly
Power cord	<ul style="list-style-type: none"> Ensure correct fitment. 	Yearly
Compressor compartment	<ul style="list-style-type: none"> Ensure that the compressor compartment is kept free of dust or other contaminants. 	Yearly
Re-evaporation tray	<ul style="list-style-type: none"> Ensure it is not cracked or shows any other signs of damage. 	Yearly
Access port	<ul style="list-style-type: none"> Ensure that the access port is sealed properly and check for moisture ingress. 	Yearly
Defrost water tube (if applicable)	<ul style="list-style-type: none"> Inspect for damage and obstructions. 	Yearly
Door switch (if applicable)	<ul style="list-style-type: none"> Ensure proper functionality to guarantee the fan in the cabinet stops, the interior lighting turns on if present, and the display shows "-0-". 	Yearly
Door alarm test	<ul style="list-style-type: none"> Ensure it activates when the door is left open. 	Yearly
Temperature	<ul style="list-style-type: none"> Ensure the appliance consistently maintains correct storage conditions. When storing valuable or temperature sensitive materials or products, it is advisable to employ a continuously monitoring autonomous alarm system. This alarm system should be designed in a manner that allows authorised individuals to promptly detect each alarm state and take the necessary corrective actions. 	Yearly

Component	Task	Frequency
High and low temperature alarms	<ul style="list-style-type: none"> • Ensure that the temperature alarms are set and work accordingly. • When storing valuable or temperature sensitive materials or products, it is advisable to employ a continuously monitoring autonomous alarm system. This alarm system should be designed in a manner that allows authorised individuals to promptly detect each alarm state and take the necessary corrective actions. 	Yearly
Door hinges	<ul style="list-style-type: none"> • Check for wear and ensure proper function. 	Yearly
Door self-closing mechanism	<ul style="list-style-type: none"> • Ensure that the door automatically closes when opened < 90 °. • Ensure that the door stays/do not close when opened > 90 °. 	Yearly
Door handle (if applicable)	<ul style="list-style-type: none"> • Ensure secure attachment and correct engagement. 	Yearly
Chart recorder (if applicable)	<ul style="list-style-type: none"> • Ensure that it accurately records and stores temperature data. 	Yearly
Lock	<ul style="list-style-type: none"> • Ensure it operates smoothly. 	Yearly
Sensors	<ul style="list-style-type: none"> • Test sensors to ensure accurate readings and functionality. 	Yearly
Cleaning	<ul style="list-style-type: none"> • Refer to the cleaning section. 	

- SPARE PARTS -



If you require spare parts, please contact your local Gram BioLine distributor. Defective parts must be replaced with original parts from Gram BioLine. Gram BioLine can only guarantee functional and safety requirements on the cabinets, if above mentioned is adhered to.

- The refrigerator/freezer must be cleaned before taken into operation.
- We recommend cleaning the refrigerator/freezer regularly to ensure efficient operation.
- We recommend using pH-neutral all-purpose cleaners and soft cleaning cloths.
- If any detergent or cleaning agent are used to clean the refrigerator/freezer, ensure that the refrigerator/freezer is thoroughly rinsed with clean water and a clean cloth to remove any cleaning agent or detergent traces.
- Ensure that the refrigerator/freezer has been dried thoroughly with a clean cloth before taken into operation.

- WARNING -

Do not use the below disinfectants and cleaners:



- Do not use abrasive cleaners.
- Do not use harsh chemicals.
- Do not use solvents.
- Do not use acidic or alkaline cleaners nor any cleaning agents that contain chloride.

- WARNING -

Do not use the below tools in general:



- Do not use metal brushes.
- Do not use water jets.
- Do not use abrasive sponges or steel wool.
- Do not use any sharp tools.
- Do not use electrical heating or steam-cleaning appliances, flames, or defroster sprays to defrost.

- WARNING -



- Do not remove the type/number plate, located inside the refrigerator/freezer (refer to type/number plate section).
- Make sure no water gets close to any electrical components.
- Do not flush the compressor compartment and evaporator with water as this may cause short-circuits in the electrical system.

Cleaning plan

The following cleaning plan represents a generic schedule for cleaning.
Use and/or conditions may impact the required frequency of the subsequent points.

Task	Minimum maintenance interval
Cleaning the air filters (if applicable)	Yearly
Cleaning the re-evaporation tray	Yearly
Cleaning the exterior	Half-yearly
Cleaning the interior	Half-yearly
Cleaning the shelves/drawers	Regularly
Cleaning the condenser and the compressor compartment	Yearly
Cleaning the door gasket	Regularly
Cleaning the defrost water tube (if applicable)	Yearly

Cleaning the air filters (if applicable)



- WARNING -

- The air filters should only be re-attached when completely dry.

Cleaning agents and tools

- pH-neutral all-purpose cleaners (optional).
- Soft cloth (optional).
- Bucket or similar (optional).

The air filters on the condenser and the front panel should be removed and cleaned with lukewarm water (max. 50° C). If the air filters are very dirty fill a bucket or similar with a mild solution of pH-neutral all-purpose cleaner. Submerge the air filters completely for approximately 10 minutes and rinse thoroughly with clean warm water. Let the air filter air-dry completely before reattaching them.

Cleaning the re-evaporation tray



- WARNING -

- Be careful not to damage the defrost water tube and the heating element (located in the tray) when cleaning.

Cleaning agents and tools

- Soft cloth.
- pH-neutral all-purpose cleaner.

It is recommended that the re-evaporation tray is checked regularly for foreign objects and cleaned with a pH-neutral all-purpose cleaner at least once a year. Rinse the tray thoroughly with clean warm water and remember to dry the re-evaporation tray completely.

Cleaning the interior and exterior



- WARNING -

- Do not use any tools or methods to speed up defrosting other than the ones specified in this instructions for use.
- Do not pour water directly into the unit.

Cleaning agents and tools

- pH-neutral all-purpose cleaners.
- Use a soft cloth to clean off dust or other contaminants from the refrigerator or freezer.

Manual defrost

Our conventional refrigerators/freezers feature automatic defrosts (see section for defrost) but the refrigerator/freezer should be manually defrosted prior to cleaning. Make sure all contents are stored elsewhere before defrosting.

Manual defrosting is done by switching off the refrigerator/freezer at the socket. Leave the door open for 24 hours and be cautious of excess water being spilled onto the floor. Be sure to keep the floor and the interior as dry as possible during the process by placing towels or similar onto the surfaces.

Remove all shelves and drawers and clean the cabinet (max. 85° C). Rinse the refrigerator/freezer thoroughly with clean warm water. Check and dry thoroughly before it is put into operation again.

Cleaning the shelves/drawers



- WARNING -

- Shelves/drawers shall be hand washed.
- Do not use excessive force when removing and inserting the shelves/drawers.

Cleaning agents and tools

- pH-neutral all-purpose cleaners.
- Soft cloth.

Remove all shelves/drawers from the refrigerator/freezer and wash them using a soft cloth. Rinse the shelves/drawers thoroughly with clean warm water. Check and dry thoroughly before it is put into operation again.

Cleaning the condenser and the compressor compartment



- WARNING -

- Ensure not to damage the condenser.
- Components in the compressor compartment may be hot.
- The refrigeration system and the hermetically sealed compressor require no maintenance.

Tools

- Use a brush, a soft cloth, or a vacuum cleaner.

The compressor compartment and in particular the condenser must be kept free from dust or other contaminants.

Cleaning the door gasket



- WARNING -

- Do not pour water directly into the unit.

Cleaning agents and tools

- pH-neutral all-purpose cleaners.
- Use a brush, a soft cloth, or a vacuum cleaner.

The door gasket should be cleaned regularly using a soft cloth. Dry the gasket completely with a clean cloth before taking the refrigerator/freezer into operation.

Cleaning the defrost water tube (if applicable)



- WARNING -

- Do not pour water directly into the unit.

Cleaning agents and tools

- pH-neutral all-purpose cleaners.
- Use a brush, a soft cloth, or a vacuum cleaner.

Remove the elastic water trap, located on the back of the cabinet, as illustrated. Inspect the defrost water tube for obstructions. Rinse and clean it and reinstall.

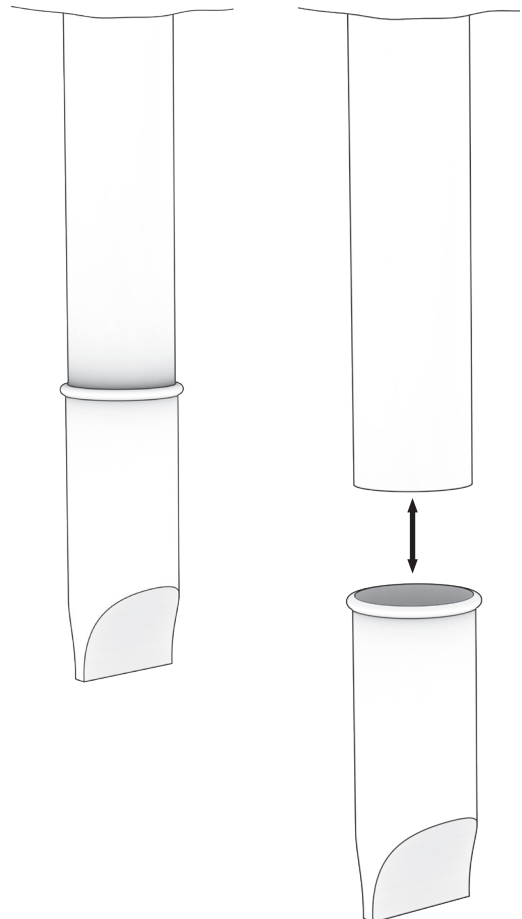

FAQ

Complication	Cause	Approach
Temperature fluctuations	Frequent door openings	<ul style="list-style-type: none"> Make the door openings as brief as possible.
	Malfunctioning temperature sensor	<ul style="list-style-type: none"> Use an independent temperature measurement device to measure the temperature inside the refrigerator/freezer to evaluate if it differs from the readings of the sensors in the appliance. In case of significant temperature difference – contact Gram BioLine technical support.
	Dirty condenser	<ul style="list-style-type: none"> Clean the condenser.
	Item distribution	<ul style="list-style-type: none"> Ensure that the contents are evenly distributed and do not obstruct air circulation.
	Ambient conditions	<ul style="list-style-type: none"> Ensure that the ambient temperature does not exceed the specified limits in this instructions for use. Ensure the cabinet is not in direct contact with sunlight or effected by other heat sources. The user must ensure that the cabinet is used in accordance with its intended use and that the humidity does not exceed 70%. Ensure adequate ventilation around the refrigerator/freezer. (Refer to surroundings section)
	Item temperature	<ul style="list-style-type: none"> Ensure that all contents are at set temperature before they are placed inside the refrigerator/freezer.
The refrigerator/freezer is not working	Power supply	<ul style="list-style-type: none"> Ensure that the power cord is securely plugged into the socket and the refrigerator/freezer.
	Power outage	<ul style="list-style-type: none"> Keep the door closed. Use a backup power source if available. Move contents to a working unit if available.
	Faulty outlet	<ul style="list-style-type: none"> Check for blown fuses. Check the circuit breaker and RCD (Residual Current Device).

- INFORMATION -

 If any issues persist, do not hesitate to reach out to Gram BioLine for professional support, at support@gram-bioline.com.

Complication	Cause	Approach
Noisy	Unlevel refrigerator/freezer	<ul style="list-style-type: none"> • Ensure that the floor is level. • Ensure that the base of the refrigerator/freezer is level. (Refer to installation section).
	Direct contact with other objects	<ul style="list-style-type: none"> • Ensure that the refrigerator/freezer is not in contact with the wall. • Ensure that the refrigerator/freezer is not in contact with another appliance or other objects.
	Fans (if applicable)	<ul style="list-style-type: none"> • Ensure the fans are operational and does not make any abnormal sounds.
Refrigerator/freezer unable to reach set temperature	Discrepancy between E-sensor and set temperature	<ul style="list-style-type: none"> • The display may show a different temperature because the E-sensor is located at the warmest spot in the unit. <p>However, the temperature in the central area where contents are stored should be at the set temperature.</p> <p>Verify this with an independent temperature measurement. If you have concerns, please contact our customer support team.</p>
	Damaged door gasket	<ul style="list-style-type: none"> • Ensure that the gasket is pliable and in good working order.
Need for spare parts	Replacement parts are required	<ul style="list-style-type: none"> • If you require spare parts, please contact your local Gram BioLine distributor.

- INFORMATION -

 If any issues persist, do not hesitate to reach out to Gram BioLine for professional support, at support@gram-bioline.com.

IQ & OQ

Installation Qualification Operation Qualification

The following IQ/OQ is intended to be a guideline, local IQ/OQ procedures can vary depending on application and items stored in the Gram BioLine cabinet.

Deviations from the specifications dictated in the PQ are to be reported in the deviation report.

The IQ/OQ is concluded if all criteria of acceptance are approved and the possible deviations are rectified or accepted.

Organisation:

Location of installation:

Model:

Serial number:

Item and revision number of instructions for use:

Status of operation:

- Active
- Inactive

Name of vendor:

Warranty:

Start: _____

End: _____

Model: _____

SN: _____

Instructions on use to starting the cabinet:

1. Training of the responsible party Date: _____ By: _____

2. Operational test of the cabinet Date: _____ By: _____

3. Responsible party _____ Tel: _____

Instructions to users:

The responsible party is trained in use of the cabinet in reference to the user manual

General use of cabinet

Objections to the mentioned:

Service & maintenance

The cabinet was delivered without defects/damage.
The cabinet started as specified in the user manual

Set values:

Setpoint temperature _____ °C

Local alarm settings:

High temperature alarm (LhL) _____ °C

Low temperature alarm (LLL) _____ °C

Factory settings					
Model/Setpoint temperature	LhL	LLL	EhL	ELL	
RF	-20 °C	+25 °C	-35 °C	+25 °C	-35 °C
RR	+5 °C	+25 °C	0 °C	+25 °C	0 °C

External alarm settings:

(See voltage free contact in user manual)

High temperature alarm (EhL) _____ °C

Low temperature alarm (ELL) _____ °C

Date: _____ Name of trained user: _____ Signature: _____ Name of instructor: _____ Signature: _____

Model: _____ SN: _____

Installation Qualification – IQ

ID	Description of installation	Reference in manual	Comply		Attachment	Notes
			Yes	No		
I-1	Ensure the cabinet is installed indoors.	page 10				
I-2	Ensure the cabinet is installed in a dry and sufficiently ventilated area.	page 10				
I-3	Ensure the cabinet is not in direct contact with sunlight or other heat sources.	page 10				
I-4	Ensure that the ambient operating temperature is within the allowed range.	page 10				
I-5	Ensure that the cabinet is not installed in a chloric/acidic environment.	page 11				
I-6	Ensure that the protective film on the cabinet is removed.	page 11				
I-7	Ensure that the cabinet is cleaned with a mild soap solution.	page 11				
I-8	Ensure that the cabinet has stood upright for 24 hours if the cabinet has been laying down.	page 11				
I-9	Ensure that the cabinet is levelled if it is equipped with legs.	page 12				
I-10	Ensure a level surface if the cabinet is equipped with wheels/castors.	page 12				
I-11	If equipped with wheels/castors: Ensure wheels/castors are locked after positioning.	page 12				
I-12	If equipped with drawers and/or glass door: Ensure that anti tilt bracket is mounted.	page 16				
I-13	Ensure a distance of $\leq 15-75$ mm between cabinet and back wall.	page 18				
I-14	Ensure that there is a minimum gap of 30 mm between cabinets.	page 18				
I-15	Ensure that the upper part of the cabinet is not covered.	page 19				
I-16	Ensure that electrical appliances are not being used inside the cabinet.	page 19				
I-17	Ensure the connection from the voltage-free contact to the external monitoring system	page 20				

Model: _____

SN: _____

Installation Qualification - IQ

ID	Description of installation	Reference in manual	Comply		Attachment	Notes
			Yes	No		
I-18	Ensure that the inner doors can operate in accordance with the instructions for use.	N/A				
I-19	Ensure the correct electrical connection (compare local values with type/number plate).	page 22				
I-20-1	Ensure that the power cord is secured by the preload cover.	page 22				
I-20-2	Ensure that the power cord is secured by the preload hanger.	page 22				
I-21	Mark the power cord with: "Do not separate when energized".	page 22				
I-22-1	Ensure equipotential bonding (applicable for ATEX Cat. 3 Zone 2 areas).	page 25				

Model: _____

SN: _____

Operation Qualification – OQ

ID	Description of operation	Reference in manual	Comply		Attachment	Notes
			Yes	No		
O-1	Turn on the cabinet – Display test (software version and variant).	page 36				
O-2	Set/adjust set-point temperature.	page 36				
O-3	Set/adjust LhL – Upper alarm limit (local).	page 39				
O-4	Set/adjust LLL – Lower alarm limit (local).	page 39				
O-5	Set/adjust Lhd – Delay of the upper alarm limit (local).	page 40				
O-6	Set/adjust LLd – Delay of the lower alarm limit (local).	page 40				
O-7	Activate/deactivate dA – Door alarm (local).	page 41				
O-8	Set/adjust dAd – Delay of the door alarm (local).	page 41				
O-9	Activate/deactivate BU – Acoustic alarms (local).	page 42				
O-10	Set/adjust EhL – Upper alarm limit (external).	page 43				
O-11	Set/adjust ELL – Lower alarm limit (external).	page 43				
O-12	Set/adjust Ehd – Delay of the upper alarm limit (external).	page 44				
O-13	Set/adjust ELd – Delay of the lower alarm limit (external).	page 44				
O-14	Activate/deactivate dA – Door alarm (external).	page 45				
O-15	Set/adjust dAd – Delay of the door alarm (external).	page 45				
O-16	Activate/deactivate BU – Acoustic external alarms.	page 46				
O-17	Set/adjust defrost cycles (dEF) per 24 hours (factory setting: 4).	page 50				
O-18	Select reference sensor for the display (dPS) (A or E).	page 51				

Model: _____

SN: _____

Deviation Report:

Deviations to the criteria of acceptance are to be documented in the deviation report. A separate deviation report shall be made for each deviation. Mark the entry with the relevant “-ID” specified in the left column in the test specifications.

-ID: _____

Description of the deviation:

Extent to which the deviation has been alleviated:

Additional notes:

Person responsible for the test:

Name: _____

Date: _____

Organisation: _____

Signature: _____

Person responsible for the verification of the test:

Name: _____

Date: _____

Organisation: _____

Signature: _____

Model: _____

SN: _____

Approval of the test results – Installation Qualification (IQ)

- The steps in the Installation Qualification – IQ were completed with positive results
- The steps in the Installation Qualification – IQ were completed with negative results

ID of steps with negative results: _____

Approval of the test results – Operation Qualification (OQ)

- The steps in the Operation Qualification – OQ were completed with positive results
- The steps in the Operation Qualification – OQ were completed with negative results

ID of steps with negative results: _____

Organisation/Responsible party: _____

Trainer/Responsible party: _____

Stamp & Signature

Stamp & Signature

Tel.

Tel.

e-mail

e-mail

Location & Date

Location & Date

Model: _____ SN: _____

Performance Qualification

Organisation:

Location of installation:

Model: _____

SN: _____

Item number: _____
(manual)

The PQ consists of inspections of the correct operation of the cabinet under predefined conditions and procedures.

Prerequisites for the PQ are IQ (Installation Qualification) and OQ (Operation Qualification), these must be concluded successfully prior to the initiation of the PQ.

Person responsible for the cabinet:

Name: _____
Date: _____
Signature: _____

Person responsible for the test:

Name: _____
Date: _____
Organisation: _____
Signature: _____

Person responsible for the verification of the test:

Name: _____
Date: _____
Organisation: _____
Signature: _____

Test duration:

Initiation (date/time): _____
Conclusion (date/time): _____
Date: _____
Organisation: _____
Signature: _____

Model: _____

SN: _____

Deviations from the specifications dictated in the PQ, are to be reported in the deviation report.
 The PQ is concluded if all criteria of acceptance are approved and the possible deviations are rectified or accepted.

Measurement – Prerequisites

ID	Description	Accepted	
		Yes	No
P-1	The cabinet must be empty while conducting tests, ie without interior fittings such as drawers, shelves etc. Attachment: Notes:		
P-2	The measurements must be conducted in accordance to IEC 60068-3-5. Attachment: Notes:		
P-3	The positioning of the sensors in the cabinet must be documented with a sketch and/or a photograph. Attachment: Notes:		

Name:

Signature:

Approved
(Yes/No):

Date:

Conducted by:

Inspected/verified by:

Model: _____

SN: _____

Deviations from the specifications dictated in the PQ, are to be reported in the deviation report.
 The PQ is concluded if all criteria of acceptance are approved and the possible deviations are rectified or accepted.

Measurement – Prerequisites

ID	Description	Accepted	
		Yes	No
P-4	Measurements made during the PQ tests must be documented and attached to the PQ. Attachment: Notes:		
P-5	Specify setpoint temperature: _____ °C Specify the ambient temperature: _____ °C Attachment: Notes:		
P-6	Allowed tolerances – <i>Select the tolerance, according to the model being tested.</i> <i>Find model-specific tolerances in appendix.</i> Tolerance: +/- _____ K Attachment: Notes:		

Name: _____ Signature: _____ Approved (Yes/No): _____ Date: _____
 Conducted by: _____
 Inspected/verified by: _____
 Model: _____ SN: _____

Deviations from the specifications dictated in the PQ are to be reported in the deviation report.
 The PQ is concluded if all criteria of acceptance are approved and the possible deviations are rectified or accepted.

Measurements – Temperature stabilisation

ID	Description	Accepted	
		Yes	No
P-7	<p>The test is intended to provide substantiation for the temperature stability inside the cabinet during normal operation.</p> <p>The temperature inside the cabinet must be stabilised – Where all the points in the working space have reached and maintained the same temperature.</p> <p>When the system is stable, document ordinary operation of the cabinet at the setpoint temperature and ambient temperature specified in P-5.</p> <p>Duration: _____</p> <p>The measurements throughout the operation test, must be documented and attached the PQ.</p> <p>Attachment:</p> <p>Notes:</p>		
P-8	<p>Are the measurements inside the allowed tolerances specified in P-6 ?</p> <p>Attachment:</p> <p>Notes:</p>		

Name: _____ Signature: _____ Approved (Yes/No): _____ Date: _____

Conducted by: _____

Inspected/verified by: _____

Model: _____ SN: _____

Deviations from the specifications dictated in the PQ are to be reported in the deviation report.
 The PQ is concluded if all criteria of acceptance are approved and the possible deviations are rectified or accepted.

Measurements – Door opening test

ID	Description	Accepted	
		Yes	No
P-9	<p>The test is intended to provide substantiation for the temperature recovery time inside the cabinet subsequently after a door opening.</p> <p>The temperature inside the cabinet must be stabilised – Where all the points in the working space have reached and maintained the same temperature, the setpoint temperature is specified in P-5.</p> <p>When the system is stable, open the door at 90° for 60 seconds.</p> <p>The measurements, throughout the door opening test, must be documented and attached the PQ.</p> <p>Duration: _____</p> <p>Attachment:</p> <p>Notes:</p>		
P-10	<p>Has the setpoint temperature specified in P-5, measured in the absolute centre of the cabinet, been achieved within the set time-frame specified in the appendix?</p> <p>Attachment:</p> <p>Notes:</p>		

Name: _____ Signature: _____ Approved (Yes/No): _____ Date: _____
 Conducted by: _____
 Inspected/verified by: _____
 Model: _____ SN: _____

Deviations from the specifications dictated in the PQ, are to be reported in the deviation report.
 The PQ is concluded if all criteria of acceptance are approved and the possible deviations are rectified or accepted.

Measurements – Pull-down

ID	Description	Accepted	
		Yes	No
P-11	<p>The test is intended to provide substantiation for the time it takes for the inside of the cabinet to reach the setpoint temperature specified in P-5. The initial temperature in the working space is the ambient temperature specified in P-5. The temperature inside the cabinet must be stabilised in all points of the working space.</p> <p>When the system is stable. Turn on the power to the cabinet.</p> <p>The measurements, throughout the pull-down test, must be documented and attached the PQ.</p> <p>Duration: _____</p> <p>Attachment:</p> <p>Notes:</p>		
P-12	<p>The time it takes the inside of the cabinet to achieve the setpoint temperature measured in the absolute centre, must not exceed the time-frame specified in the appendix.</p> <p>Have the criteria been met?</p> <p>Attachment:</p> <p>Notes:</p>		

Name: _____

Signature: _____

Approved
(Yes/No): _____

Date: _____

Conducted by: _____

Inspected/verified by: _____

Model: _____

SN: _____

Deviations from the specifications dictated in the PQ, are to be reported in the deviation report.
 The PQ is concluded if all criteria of acceptance are approved and the possible deviations are rectified or accepted.

Measurements – Hold-over

ID	Description	Accepted	
		Yes	No
P-13	<p>The test is intended to provide substantiation for the time it takes for the temperature inside the cabinet to reach the end temperature specified in the appendix. Ambient temperature and setpoint temperature is specified in P-5.</p> <p>The temperature inside the cabinet must be stabilised – Where all the points in the working space have reached and maintained the same temperature throughout, the tolerances are specified in P-6.</p> <p>When the system is stable, turn off the power to the cabinet.</p> <p>The measurements, throughout the hold-over test, must be documented and attached the PQ.</p> <p>Attachment:</p> <p>Notes:</p>		
P-14	<p>The times it takes the inside of the cabinet to reach the end temperature, must at least be the time specified in the appendix.</p> <p>Duration: _____</p> <p>Have the criteria been met?</p> <p>Attachment:</p> <p>Notes:</p>		

Conducted by: _____ Name: _____ Signature: _____ Approved (Yes/No): _____ Date: _____

Inspected/verified by: _____

Model: _____ SN: _____

Deviation Report

Deviations to the criteria of acceptance are to be documented in the deviation report. A separate deviation report shall be made for each deviation. Mark the entry with the relevant "P-ID" specified in the left column in the test specifications.

P-ID: _____

Description of the deviation:

Extent to which the deviation has been alleviated:

Additional notes:

Person responsible for the test:

Name: _____

Date: _____

Organisation: _____

Signature: _____

Person responsible for the verification of the test:

Name: _____

Date: _____

Organisation: _____

Signature: _____

Model: _____

SN: _____

Approval of the test results – Performance Qualification (PQ)

The steps in the Performance Qualification – PQ were completed with positive results

The steps in the Performance Qualification – PQ were completed with negative results

ID of steps with negative results: _____

Additional notes:

Organisation/Responsible party: _____

Trainer/Responsible party: _____

Stamp & Signature

Stamp & Signature

Tel.

Tel.

e-mail

e-mail

Location & Date

Location & Date

Model: _____ SN: _____

Appendix

BioCompact II	Tolerances	Door opening recovery time (minutes) ***	Permissible deviation	Pull-down (minutes)	Permissible deviation	Hold-over range*	Hold-over	Permissible deviation
REFRIGERATORS (RR)								
210 (Solid door)	+/- 3K	4	35 %	23	5 %	5 °C → 10 °C	66	5 %
210 (Glass door)	+/- 3K	4	10 %	28	5 %	5 °C → 10 °C	43	5 %
310 (Solid door)	+/- 3K	4	35 %	24	5 %	5 °C → 10 °C	55	5 %
310 (Glass door)	+/- 3K	4	20 %	28	5 %	5 °C → 10 °C	42	10 %
410 (Solid door)	+/- 3K	8	15 %	21	5 %	5 °C → 10 °C	47	10 %
410 (Glass door)	+/- 3K	7	10 %	22	5 %	5 °C → 10 °C	33	5 %
610 (Solid door)	+/- 3K	6	35 %	15	5 %	5 °C → 10 °C	**	10 %
610 (Glass door)	+/- 3K	6	35 %	**	5 %	5 °C → 10 °C	**	10 %
FREEZERS (RF)								
210 (Solid door)	**	15	20 %	53	10 %	-20 °C → -10 °C	56	5 %
310 (Solid door)	**	11	10 %	62	5 %	-20 °C → -10 °C	56	5 %
410 (Solid door)	**	19	10 %	71	10 %	-20 °C → -10 °C	42	10 %
610 (Solid door)	**	10	20 %	40	10 %	-20 °C → -10 °C	**	10 %

*) The temperature span between the initial temperature and the end temperature in the hold-over test P-13,14.

**) Please contact your local distributor for current information.

***): 90° opening 1 minute

Note:

Refrigerators (RR): Ambient temperature +25 °C
Setpoint temperature +5 °C

Freezers (RF): Ambient temperature +25 °C
Setpoint temperature -20 °C

Name: _____ Signature: _____ Approved (Yes/No): _____ Date: _____

Conducted by: _____

Inspected/verified by: _____

Model: _____ SN: _____

Index

A	
Access port	61
Alarm settings	39, 43
Anti tilt bracket	16
B	
Base of cabinet	12
Basket	31, 32
C	
Cabinet components	6, 8
Castors	12
Cleaning	56, 104
Connection to power	22
D	
Datasheet	64
Declaration of conformity	88
Defrost	50, 60
Digital display	36
Display sensor	51
Disposal	63
Door gasket	57
Door hinging	14
Door lock	55
Drawer	27, 29
E	
Electric low-temperature protection	52
Equipotential bonding	25
Error codes	38
Escorted/set alarm limits	49
F	
FAQ	108
G	
General cleaning	103
General info	58
General maintenance	100
I	
Important	62
Initial setup steps	10
Installation	10
IQ, OQ and PQ	110
L	
Load line	53
Low-temperature protection	52
M	
Maintenance	56, 101
Menu	37
Mounting	17
O	
Options assembly	26
Ordinary use	53
P	
Parameter settings	47
Piping diagram	99
Power, Connection to	22, 23, 24
Protective equipment	11
Protective film	11
Q	
Quick guide	2
R	
Reversal of door	13
S	
Safety	5
Sensor offset	47
Sensors	47, 48
Service	58
Shelf	33, 34, 35
Start-up	36
Surroundings	18
Symbols used in the manual	5
T	
Type/number plate	59
V	
Voltage-free contact	20
W	
Wall mounting	17
Wiring diagram	92



Gram Scientific ApS

Aage Grams Vej 1 · 6500 Vojens · Denmark

Tel: +45 73 20 13 00

e-mail: info@gram-bioline.com

www.gram-bioline.com



Biostorage you can depend on