

# ExGuard

## INSTRUCTIONS FOR USE

Model: ER600W

Original Instructions for use

Item No.: 765042431

Revision No.: 20260430

Language: English



Biostorage you can depend on

# Quick Guide – ExGuard

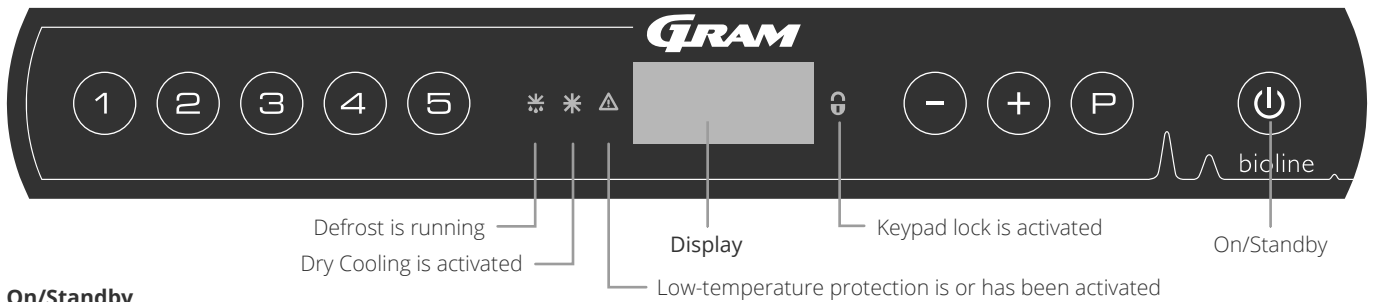

## On/Standby

Press the key to turn the cabinet on. Press the key for 6 seconds to switch to standby. The software version of the cabinet will be shown when turning the cabinet on, followed by the variant and a display test. The cabinet is ready when the temperature is displayed. The cabinet will automatically start a defrost-cycle when turned on, and terminate it again after a system check.



**ATTENTION** – Turning off the cabinet will result in the extraction system also powering down. Ultimately resulting in a rise in temperature inside the storage chamber.

## Setting the temperature

Temperature adjustments are done by holding the key and pressing either or . Confirm the settings by letting go of the keys.

## User menu and alarm settings

Menu Access  +  →	↓	→		
	dC			Dry cooling - dC-[HO=Off/H1= On]. Press and hold  + , press  to proceed to "LAL"
Local alarm settings	LAL	LhL	[° C]	Upper alarm limit. Code for activated alarm [A2]
		LLL	[° C]	Lower alarm limit. Code for activated alarm [A3]
		Lhd	[min.]	Delay of upper alarm limit
		LLd	[min.]	Delay of lower alarm limit
		dA	On/Off	Door alarm. Code for activated alarm [A1]. [1=On/0=Off]
		dAd	[min.]	Delay of door alarm
		BU	On/Off	Acoustic signal for alarm codes [A1], [A2] and [A3]. [1=On/0=Off]
External alarm settings	EAL	EhL	[° C]	Upper alarm limit. Code for activated alarm [A4]
		ELL	[° C]	Lower alarm limit. Code for activated alarm [A5]
		Ehd	[min.]	Delay of upper alarm limit
		ELd	[min.]	Delay of lower alarm limit
		dA	On/Off	Door alarm. Code for activated alarm [A1]. [1=On/0=Off]
		dAd	[min.]	Delay of external door alarm
		BU	On/Off	Acoustic signal for external alarm codes [A1], [A4], [A5]. [1=On/0=Off]
Offset of sensors	cAL	cA	[° K]	Offset of A-sensor. Reference sensor for the refrigeration system
		cE	[° K]	Offset of E-sensor. Reference sensor for the display and alarms
	ALL			Activation of escorted alarm limits. [FAS]= locked limits/[ESC] = follows setpoint
	dEF			Number of defrosts per 24 hours (4 is factory setting)
	dPS			Reference sensor for the display (A, E or F) (E is factory setting)

## Other shortcuts

Keys	Duration	Function
+	> 3 seconds	Start or stop a defrost
+	> 6 seconds	Activating/deactivating the keypad lock
	-	Shows the temperature setpoint value
	-	Shows the highest registered temperature spike (since the last reset of the alarm history)
	-	Shows the lowest registered temperature spike (since the last reset of the alarm history)
+	> 3 seconds	Clear and reset the alarm history
+  +	> 6 seconds	Reset of the set parameters. Restores factory settings
+	> 3 seconds	Access to the user menu and alarm settings

### Example: Setting the upper limits for the alarms; LhL

- ↳ Press and hold (P) + (1) until the display shows LAL
- ↳ Press (P) to select LAL, LhL is now shown in the display
- ↳ Press (P) to select LhL, 25 is shown in the display
- ↳ Press (-) or (+) to set the desired value for the upper temperature limit
- ↳ Press (P) to confirm the set value
- ↳ Press (Ⓜ) to return to LAL
- ↳ Press (+) to reach the next level, LLL
- ↳ Lhd, LLd, dA, dAd and BU are located on the same level
- ↳ Press (Ⓜ) three times to leave the user menu

Alarm codes	[A1]	Door alarm
	[A2]	The upper alarm limits, (LhL) is or has been activated
	[A3]	The lower alarm limits, (LLL) alarm is or has been activated
	[A4]	External high alarm EhL is or has been activated (see page 26)
	[A5]	External low alarm ELL is or has been activated (see page 26)

### Acknowledging an acoustic alarm

Alarm code [A1]: Press (P) to acknowledge. Temperature alarm codes [A2] and/or [A3]: Flashes in the display. Press (P) to acknowledge. The display will continue to flash if the temperature is outside the alarm limits.

### Latching alarms: [A2], [A3], [A4], [A5]

Due to the potential implications of alarms, the red alarm triangle icon will turn on along with the corresponding alarm code will flash in the display. The alarm state will remain on until until it is acknowledged by pressing (P).

### Read-out of the max./min. temperature

Read the highest recorded temperature inside the cabinet by holding down (+). Read the lowest recorded temperature inside the cabinet by holding down (-).

### Reading the alarm history - Example [A2]

[A2] Flashes in the display - This means that the temperature has exceeded the set value for the upper temperature limit, LhL. Press (P) to acknowledge the [A2]. The display continues to flash, indicating that there is information in the alarm history. Press (+), Htt (High temperature time) is shown. Press (P) to see for how long the temperature was above the set alarm limit. Press (Ⓜ) to return to Htt. Press (+) to reach Ht (Highest temperature). Press (P) to read the highest recorded temperature during Htt. Press (Ⓜ) to return to Ht and press (Ⓜ) again to leave the alarm history function. The procedure for reading an [A3] alarm is identical, apart from entering the alarm history with the (-) key. When reading out temperatures below set limits, the parameters are Ltt and Lt. A flashing display with no alarm codes indicates that the alarm codes have been acknowledged, but the alarm system contains information.

### Resetting the alarm temperature and the alarm history

Resetting of the max./min. and alarm history is done by holding (-) and (+) for more than 3 seconds. An acoustic signal will be given when reset is complete.

### Sensor read-out and error codes

Menu Access (P) + (S) →	↓	(P) → [° C]	Display code and its message	
Sensor for refrigeration system	P-A	Value on sensor for refrigeration system	F1	Error on sensor for refrigeration system
Sensor for evaporator	P-b	Value for evaporator sensor	F2	Error on evaporator sensor
Sensor for condensor	P-C	Value for condensor sensor	F3	Error on condensor sensor
Sensor for display and alarms	P-E	Value for display and alarm sensor	F5	Error on sensor for display and alarm
An overheated condensor can be caused by a clogged condensor - clean the condensor			F7	Overheated condensor
Open door indicator. Alarm [A1] will activate if the door is open longer than alarm limits			-0-	Door open

# Table of content

---

<b>Quick Guide – ExGuard</b> .....	2	<b>Opening and closing the door</b> .....	39
<b>Table of content</b> .....	4	<b>Parameter settings</b> .....	40
<b>Safety</b> .....	5	Damper open time .....	40
Before you proceed .....	5	Feedback sensor .....	41
<b>Cabinet components</b> .....	6	Feedback sensor activation .....	41
<b>Installation</b> .....	8	Extraction alarm – Not available .....	44
Initial setup .....	8	Extraction extra time .....	45
Anti tilt bracket .....	10	Periodic extraction frequency .....	45
Surroundings .....	11	Buzzer .....	46
Connection to the ventilation system .....	12	<b>Ordinary use</b> .....	47
Voltage-free contact .....	13	<b>Regular maintenance</b> .....	48
Equipotential bonding .....	16	Cleaning .....	48
<b>Digital display</b> .....	17	Door gasket .....	49
<b>Start-up – conventional operation</b> .....	18	<b>General info</b> .....	50
The digital display (9 keys) .....	18	Responsibility .....	50
Walkthrough of menu .....	19	Type/number plate .....	51
Error codes .....	20	Defrost water .....	52
Dry cool .....	21	Door self-closing mechanism .....	53
<b>Local alarm settings</b> .....	22	Door lock .....	54
Local high alarm .....	22	Important .....	56
Local low alarm .....	22	Disposal .....	57
Local high alarm delay .....	23	<b>Datasheet</b> .....	58
Local low alarm delay .....	23	ExGuard ER600W .....	58
On/Off local door alarm .....	24	<b>Declaration of conformity</b> .....	60
Delay for local door alarm .....	24	<b>Piping diagram</b> .....	61
Local acoustic settings .....	25	<b>Wiring diagram</b> .....	62
<b>External alarm settings</b> .....	26	<b>General maintenance information</b> .....	64
External high alarm .....	26	Maintenance plan .....	65
External low alarm .....	26	<b>General cleaning information</b> .....	67
External high alarm delay .....	27	Cleaning plan .....	68
External low alarm delay .....	27	<b>FAQ</b> .....	72
On/Off external door alarm .....	28	<b>IQ &amp; OQ</b> .....	74
External door alarm delay .....	29	Installation & Operation Qualification .....	74
External acoustic settings .....	30	<b>PQ</b> .....	82
<b>Parameter settings</b> .....	31	Performance Qualification .....	82
Sensor offset .....	31	<b>Index</b> .....	94
Escorted/set alarm limits .....	33		
Defrosts/24 hours .....	34		
Display sensor .....	35		
<b>Start-up</b> .....	36		
The digital display (7 keys) .....	36		
Walkthrough of menu .....	37		
Error codes .....	38		

---

Copyright © 2006- Gram BioLine, a division of Gram Scientific ApS, Denmark. All rights reserved.

The content of this publication is owned by Gram BioLine, unless otherwise noted, and is protected by Danish and international copyright laws and provisions.

Information and images may not be used, copied or transferred without the express written permission of Gram BioLine.

Manufactured by  
**Gram Scientific ApS**  
Aage Grams Vej 1 · 6500 Vojens · Denmark  
Tel: +45 73 20 13 00  
e-mail: info@gram-bioline.com  
www.gram-bioline.com



## Before you proceed

Make sure to read the instructions for use thoroughly before using the cabinet for the first time. In the event of need for product support, do not hesitate to contact us at: [support@gram-bioline.com](mailto:support@gram-bioline.com)

This instructions for use is intended for the following product series:

### ExGuard

We recommend that you read this instructions for use thoroughly before using the cabinet for the first time. Gram BioLine does not guarantee safe operation if the cabinet is used for anything other than its intended use. Contents of the instructions for use can be subject to change without notice. No part of this instructions for use may be reproduced in any form without expressed written consent of Gram BioLine. Gram BioLine guarantees the cabinet under certain warranty conditions. Gram BioLine is not responsible for any loss or damage of content.

This instructions for use should be considered as an integral part of the cabinet and should be stored close to the cabinet and be easily accessible. If the instructions for use is lost, please refer to your local distributor or Gram BioLine for a replacement. For current versions of the instructions for use, please go [www.gram-bioline.com](http://www.gram-bioline.com).

## Intended Use

**Gram BioLine ExGuard** cabinets are designed and manufactured for temperature-controlled storage of items potentially emitting noxious, malodourous and /or explosive atmospheres, where there is a risk that these atmospheres may pose a health hazard to the user and cabinet surroundings.

Enabling placement of ExGuard refrigerators and freezers, in Zone 2 areas categorised according to EN/IEC 60079-14. The user must ensure that the cabinet is used in accordance with its intended use.

The cabinet is designed for the following operating range:

ER: -2/+20 °C

at the maximum ambient temperature specified in this instructions for use, and a maximum relative humidity of 70%. The user must ensure that the cabinet is used in accordance with its intended use.

Abnormal use or use conflicting with the intended use or guidelines stipulated in the product documentation can lead to: danger to patient safety, damage to stored items, damage to cabinet, danger to user

Gram BioLine equipment is designed to be used in a system with additional monitored independent alarms to ensure timely reaction to alarms and thereby maximum item safety.

When storing valuable or temperature-sensitive materials or products, it is advisable to employ a continuously monitoring autonomous alarm system. This alarm system should be designed in a manner that allows authorised individuals to promptly detect each alarm state and take the necessary corrective actions.

## Symbols used throughout the instructions for use



**Hazard**



**Risk of electric shock**



**Risk of material damage**



**Risk of personal injury**



**Risk of burning/freezing**



**Info**



**Risk of fire /  
flammable materials**



**Risk of explosion/  
explosive materials**

# Cabinet components

*This part describes the main components pertinent to the user.*

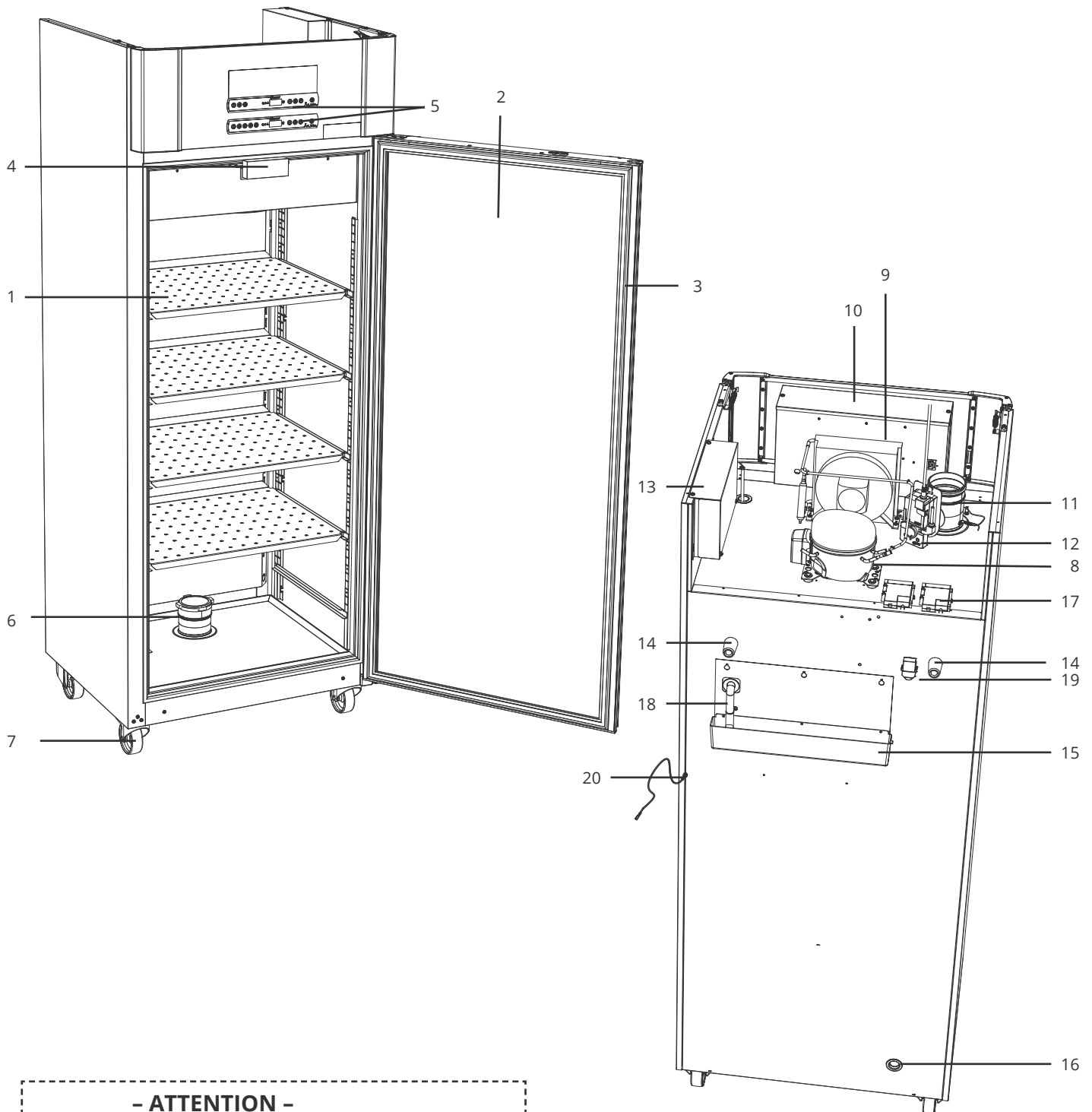

## **- ATTENTION -**



In the event of technical difficulties or malfunction, always contact Gram BioLine technical support or a Gram BioLine authorised service partner.

1. **Shelves and wall rails** – Ensure that the shelves are fixated correctly, before exerting load on them. All shelves and/or drawers must be supported by at least two shelf and/or drawer supports each.
2. **Door** – Ensure that the door is closed completely after use. To minimise fluctuations in temperature, make the door openings as brief as possible.
3. **Door gasket** – Ensure that the gasket is pliable and in good working order. Keep the door gasket clean, find instructions in this instructions for use.
4. **Electromagnet for the door-lock system** – Used to hold the door locked via the corresponding anchor-plate on the door and prevent access unless the extraction process is activated. Ensure it does not show any sign of damage. If so, do not use the cabinet and contact Gram BioLine or your local supplier for further aid.
5. **Digital displays for the controllers** – Use the lower display to show the cabinet’s temperature. The status of the extraction and the door-lock system are displayed on the upper display.
6. **Inlet valve for the exhaust** – Lets air into the cabinet during the extraction process. Ensure it does not show any sign of damage. If so, do not use the cabinet and contact Gram BioLine or your local supplier for further aid.
7. **Base of cabinet** – Ensure cabinets with legs are levelled properly and cabinets with castors are placed on a level surface and locked as mentioned in this instructions for use.
8. **Compressor** – Ensure it is not dented or shows any other signs of damage.
9. **Condenser** and fan – Ensure it is not dented or shows any sign of damage.
10. **Control box for the refrigeration system** – Enclosure for the controller, sensors and other parts that monitor and manage the refrigeration system. Ensure it is not dented or shows any other signs of damage.
11. **Outlet valve for the exhaust** – The external connection point for the ventilation to let hazardous and toxic fumes/vapours out of the cabinet during the extraction process. Ensure it does not show any sign of damage. If so, do not use the cabinet and contact Gram BioLine or your local supplier for further aid.
12. **Servo motor for the exhaust system** – Ensure the motor connection is properly connected and is not loose or partly connected. In the event of failure, do not use the cabinet and contact Gram BioLine or your local supplier for further assistance.
13. **Control box for the exhaust and door-lock system** – Enclosure for the controller, sensors and other parts that monitor and manage the exhaust and the door-lock system. Ensure it is not dented or shows any other signs of damage.
14. **Rubber spacers** – Are intended to ensure appropriate space between the cabinet and the wall. Do not remove.
15. **Re-evaporation tray** – Ensure it is not cracked or shows any other signs of damage. It is recommended to clean it before applying power to the cabinet for the first time.
16. **Access port** – Used to lead sensors and similar into the cabinet. Ensure that the access port is sealed properly prior to start-up.
17. **Box for the voltage-free contact** – Used to connect to an external alarm system. Instructions for connection is found in this instructions for use. Remember to set the external alarms (EAL).
18. **Defrost** water tube – Outlet for the defrost water coming from the evaporator tray inside the cabinet. Ensure it is not damaged or shows any sign of damage.
19. **Pressure equalisation valve** – Used to equalise pressure inside the cabinet when opening the door. Ensure it is not damaged or shows any sign of damage.
20. **Equipotential bonding** – To ensure compliance with ATEX regulations EN 60079-14. See installation section for specifications.



**- ATTENTION -**

If parts show signs of damage; do not use the cabinet and contact Gram BioLine or supplier for further aid.

# Installation

## Initial setup

This part of the instructions for use describes how to set up the cabinet.



- I-1\*:** Due to safety and operating considerations, the cabinet must not be used outdoors.
- I-2\*:** The cabinet should be installed in a dry and sufficiently ventilated area.
- I-3\*:** To ensure efficient operation, the cabinet should not be installed in direct sunlight or close to heat sources.

### I-4\*: Ambient temperature

Cabinet	Minimum ambient operating temperature	Maximum ambient operating temperature
ER with solid door	+10 °C	+43 °C
ER with glass door	+10 °C	+38 °C



- I-5\*:** Avoid placement of the cabinet in a chloric/acidic environment due to risk of corrosion.



- I-6\*:** The cabinet is shipped with a protective film that shall be removed prior to use.

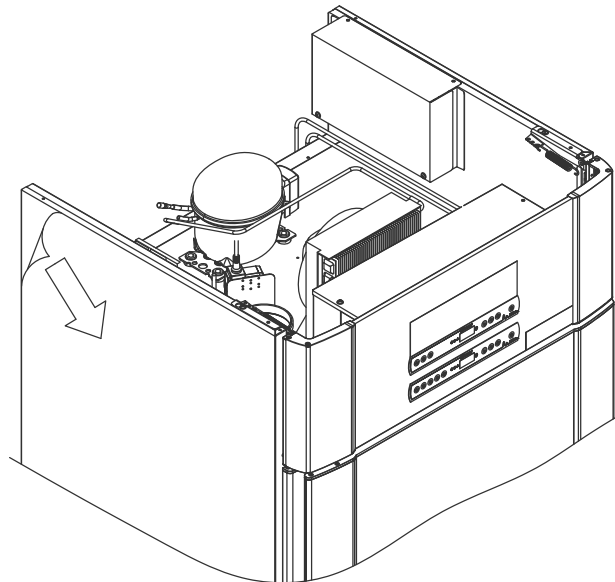

### - WARNING - POTENTIAL ELECTROSTATIC CHARGING HAZARD

Removing protective packaging and film may cause electrostatic discharge. Protective packaging and film shall not be removed in ATEX zones.



*This part of the instructions for use describes how to adjust the legs/castors on the cabinet.*



Ensure the use of appropriate personal protective equipment such as gloves, when handling the cabinet.



**I-7\*:** Clean the cabinet with a mild soap solution prior to use.



**I-8\*:** If the cabinet has been laying down (ex. during transport.). Then the cabinet must stand up-right for 24 hours prior to use, this enables oil in the compressor to flow back into place.

**I-9\*:** Cabinets equipped with legs should be levelled as shown in the illustration below.

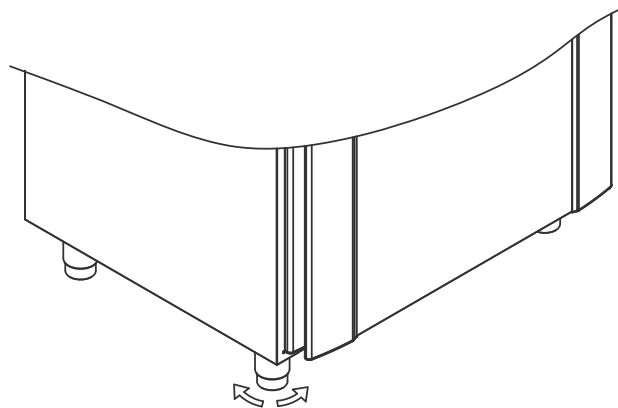

**I-10-11\*:** For cabinets equipped with castors, the floor must be level to ensure stable positioning and safe use. When the cabinet is positioned, the two front castors should be locked.

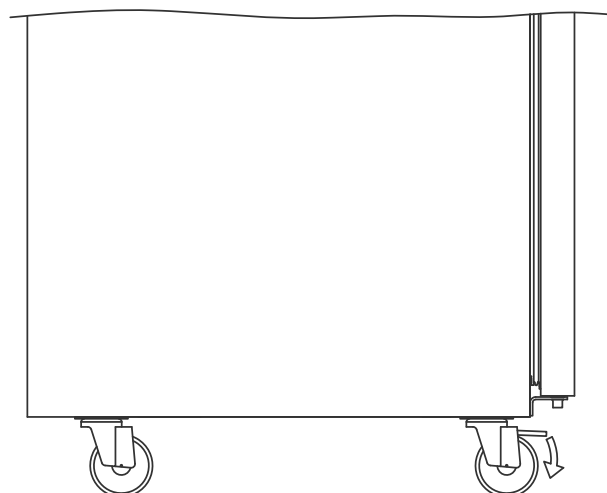

# Anti tilt bracket



**I-12\*:** Cabinets with drawers and/or a glass door must be secured to a stable vertical surface, ensuring that the cabinet cannot tip over when the drawers are drawn to the outermost position, or the door is open. Brackets for securing is included.

Find the instructions for the tilt bracket below.

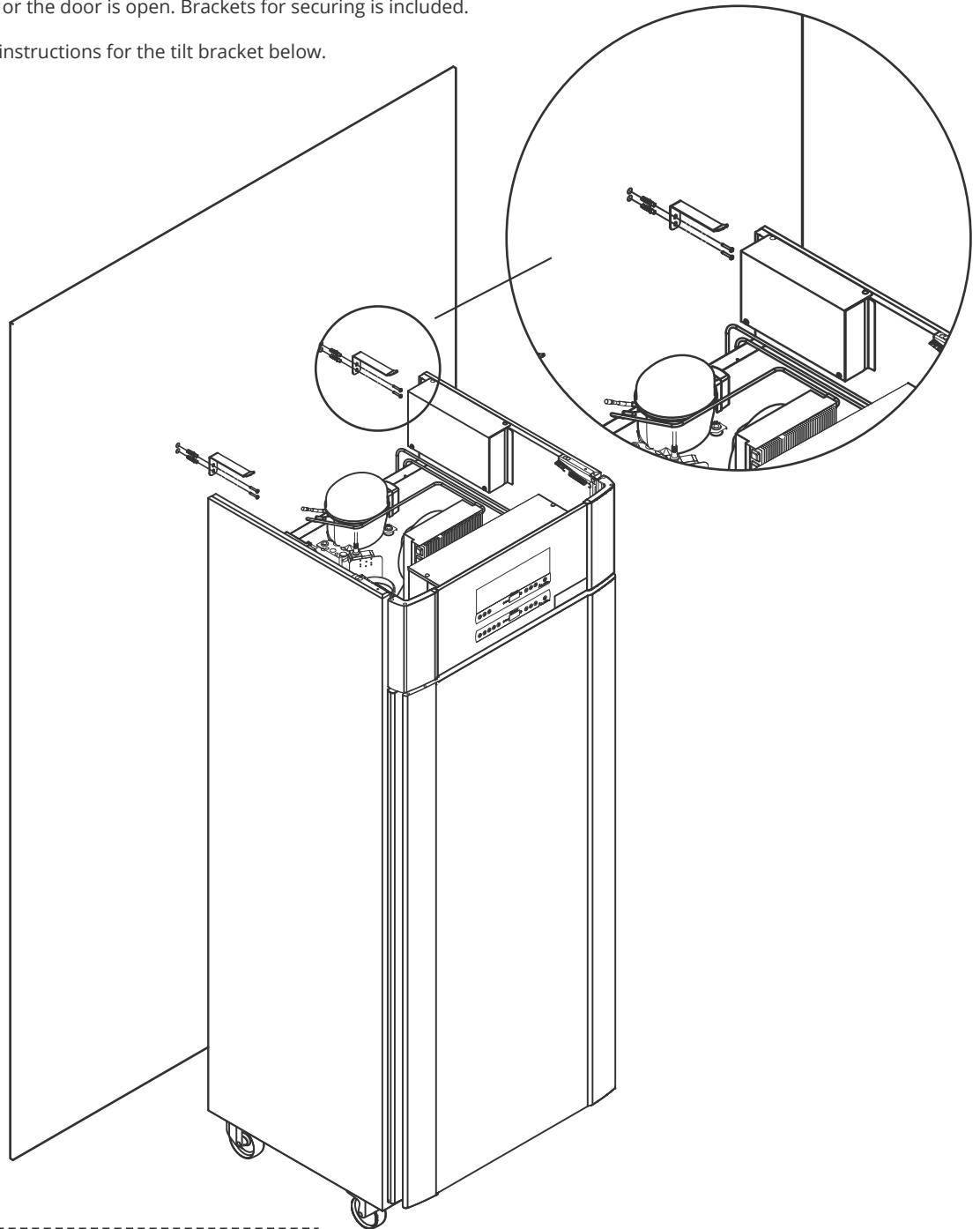

**- ATTENTION -**

The anti tilt brackets must be fitted when installing the cabinet, ensuring that the users, surroundings and stored items are not damaged by the cabinet.

# Surroundings

**I-13\*:** The cabinet's back should be placed as close to the wall as possible. Maximum allowed distance between wall and the cabinet is 75 mm.



**I-14\*:** There must be at least a 30 mm gap between cabinets.



**I-15\*:** Do not cover the upper part of the cabinet if it has a top mounted compressor.



**I-16\*:** Do not use electrical appliances inside the cabinet.



The cabinet is not suited for storing items that emit vapours which, either by themselves or in combination with other chemicals or water, may condensate and corrode the cabinet and its components.

All items in the cabinet that are not encapsulated, or wrapped, should be covered to reduce the risk of corrosion of the cabinet and its components.

15-75 mm

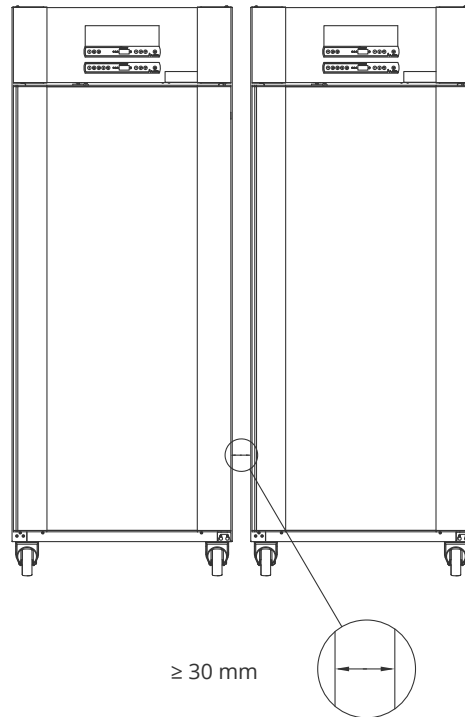
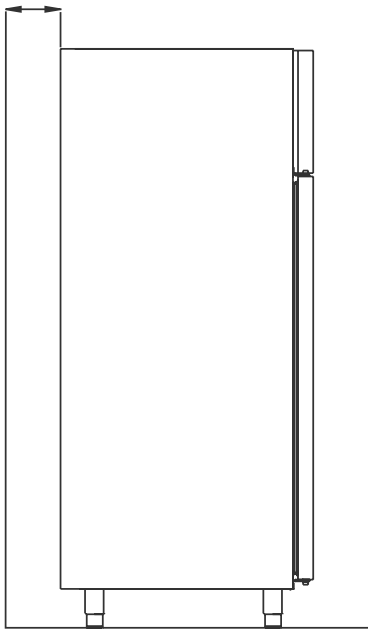

**- For Ex environments -**  
 Open containers inside the storage chamber may impact the ATEX zone classification

## Connection to the ventilation system

The cabinet must not be taken into operation prior to connecting it to a dedicated ventilation system. The ventilation must be fit for purpose in relation to the use of the stored items and general installation conditions. It is the responsibility of the user to ensure that the ventilation system is functional and is providing adequate suction. The connection assembly between the ventilation system ducting and the cabinet must seal properly. See illustration below for the location of connection to the cabinet.

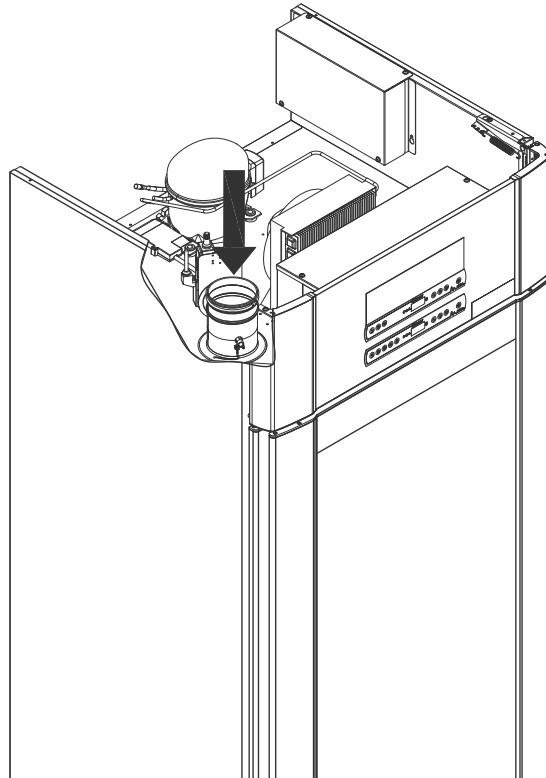

Stored items must be closed and sealed to minimise the potential concentration of noxious, malodorous and/or explosive atmospheres. Please refer to EN 60079-14: Explosive atmospheres – Electrical installations design, selection and erection for installation requirements in an ATEX environment.

### – ATTENTION –

Factory settings for; Extraction time (damper open time – "dot"), Extra extraction time (Extra Extraction – "EUE") and Periodic Extraction frequency (Periodic Extraction – "PE") must be assessed for adequacy and adjusted accordingly if required.



#### – Requirements for installation –

144 m<sup>3</sup>/h air flow per cabinet\*  
100 mm spiral ducting connection to the ventilation system.  
\* Prerequisites: 600 L air change over 15 seconds, where the average speed is 5 m/s for Ø100 mm exhaust ducting.



#### – For Ex environments –

Special conditions for safe use may apply to this product when installing in an EN 60079-10 environment. Please see corresponding Ex certificate for specifications.

# Voltage-free contact

*This part of the instructions for use covers the voltage-free contact.*

**I-17\*:** The illustration below shows the three connectors for the relay (used ex. in connecting to CTS or other external monitoring systems). The three connections, are respectively: Common, NO and NC.

The moment when voltage is applied the controller draws the relay, this makes it possible for the controller to respond to both high and low alarms, door alarms and power failures. Temperature alarms and door alarms must be configured in the external alarm settings (EAL) before they will activate the voltage-free contact. Find instructions on setting external alarms in the parameter settings section.

The wires that are connected in the connection block for the voltage-free contact, are secured in place by the press-fit plate that is pressed onto the block, thereby also preventing access to the electrical circuit.

Connection of the voltage-free contact should be done by a qualified installer.

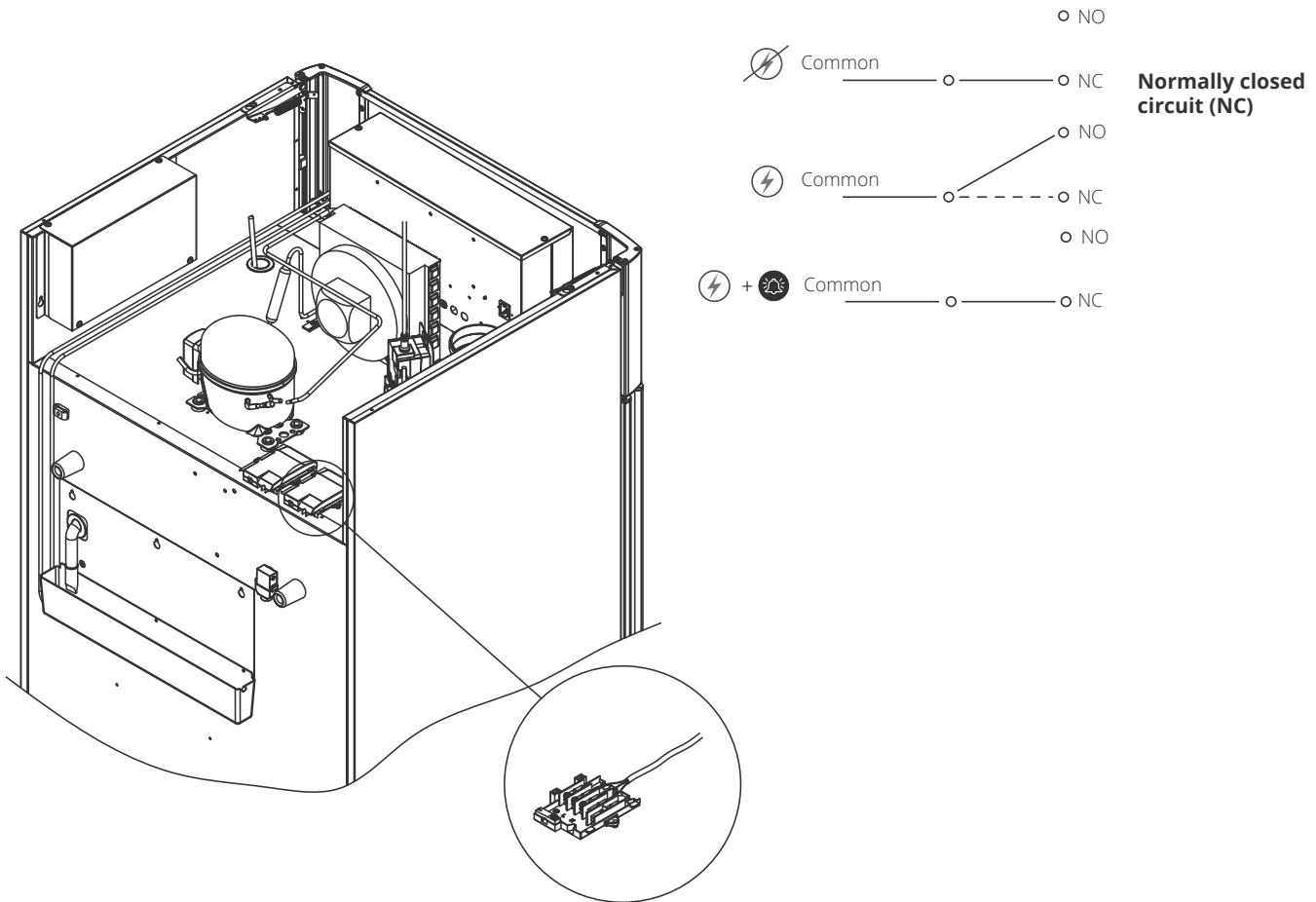

## Connection to power

*Read the following part thoroughly before connecting the cabinet. Contact a qualified electrician if in doubt.*

**I-19\*:** **When setting up in an ordinary scenario that is not subject to regulations for EN 60079-15 zone 2:**

The appliance may be connected in accordance with applicable local heavy current regulations.

**Note that there are special regulations for products that are in accordance with EN 60079-15 zone 2 and EN 60079-14: Explosive atmospheres–Electrical installations design, selection and erection.**

The appliance has been manufactured in accordance with EN 60079-15: Electrical apparatus for explosive gas atmospheres–Part 15: Type of protection II 3G Ex ec nC ic IIB Tx Gc. Zone 2 is the applicable zone.

If the appliance is to be installed in a zone 2 environment, specialist personnel should perform the installation, or be consulted beforehand, in order to ensure that the appliance is installed in compliance with the guidelines currently contained in the standard.

**I-20-2\*:** The cabinet is intended for connection to alternating current. The connection values for voltage (V) and frequency (Hz) are given on the type/number plate. The power cord from the mains is plugged in the terminal box.

The plug is then fixated in place by the hanger that is built into the terminal box.

**Please note :** the hanger should be fitted tightly around the plug, as shown.

The appliance must be connected to the external power supply using a suitable device which mechanically prevents the plug and socket from being separated unintentionally.

**I-21\*:** The connection must be labelled:  
**"DO NOT SEPARATE WHEN ENERGIZED"**

### – ATTENTION –

Fuses and similar must never be removed or replaced while the appliance is connected to a power source.

The electrical terminal box must never be opened while the appliance is connected to a power source.

The compressor's starting equipment must never be dismantled while the appliance is connected to a power source.

Whenever electrical components are dismantled or replaced, the appliance must be moved to an area in which there is no risk of ignition caused by the electrical components or gases contained in the appliance.

Never use the cabinet if the plug is damaged. The cabinet should be examined by a Gram BioLine service technician in such cases.

When setting up in an ordinary scenario that is not subject to regulations for Zone 2:

The appliance may be connected in accordance with applicable local heavy current regulations.

**In both cases**

Use a three-wire plug, if the power outlet is intended for a three-wire plug, the lead in green/yellow insulation should be connected to the ground terminal.

Power must be connected via a wall socket. The wall socket should be easily accessible. All earthing requirements stipulated by the local electricity authorities must be observed. The cabinet plug and wall socket should then have correct earthing. If in doubt, contact your local supplier or authorised electrician.

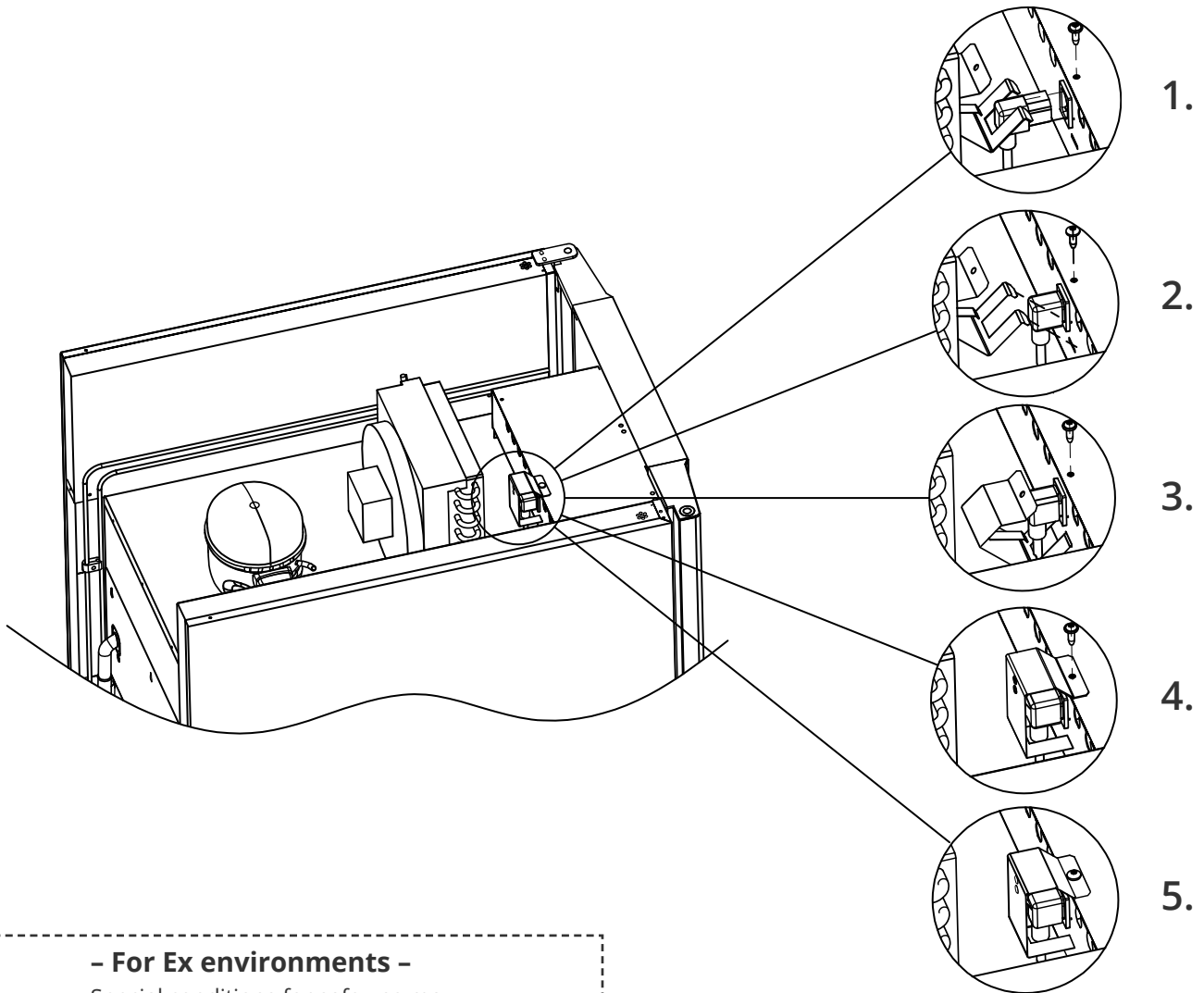

**- For Ex environments -**



Special conditions for safe use may apply to this product when installing in an EN 60079-14 environment.

Please, see corresponding Ex certificate for specifications.

**- Technical Support -**

In the event of technical difficulties always contact Gram BioLine technical support or a Gram BioLine authorised service partner.

Never dismantle the terminal box or any other electrical component.

# Equipotential bonding



**I-22-1\*:** For installation in ATEX Cat. 3 Zone 2 areas, it is mandatory to have a equipotential bonding, it is not sufficient to use protective earth through the mains connection.  
To secure equipotential bonding of the unit – The mounted external bonding conductor must be used in accordance with national installation requirements e.g. EN 60079-14.

- Mounting of the bonding conductor should be done according to the following illustrations.
- Please find location for connection facilities on the back of the cabinet marked with: **“Attention – Equipotential bonding”**.
- The bonding conductor should be at least 4 mm<sup>2</sup> guage.
- Use a ring terminal to ensure adequate bonding.
- Use the supplied M5 machine screw and washer to attach the bonding conductor to the cabinet. Tighten the machine screw to 3.2 Nm.

Bonding of the cabinet is illustrated on this page.



## - ATTENTION -

This location is the only manufacturer-approved location for equipotential bonding.

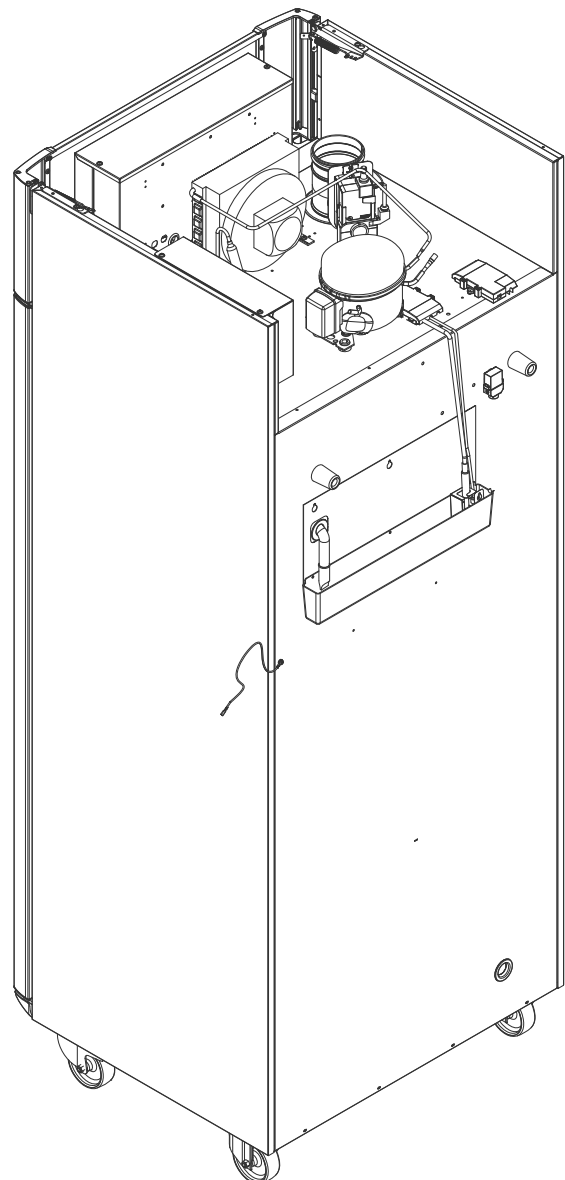
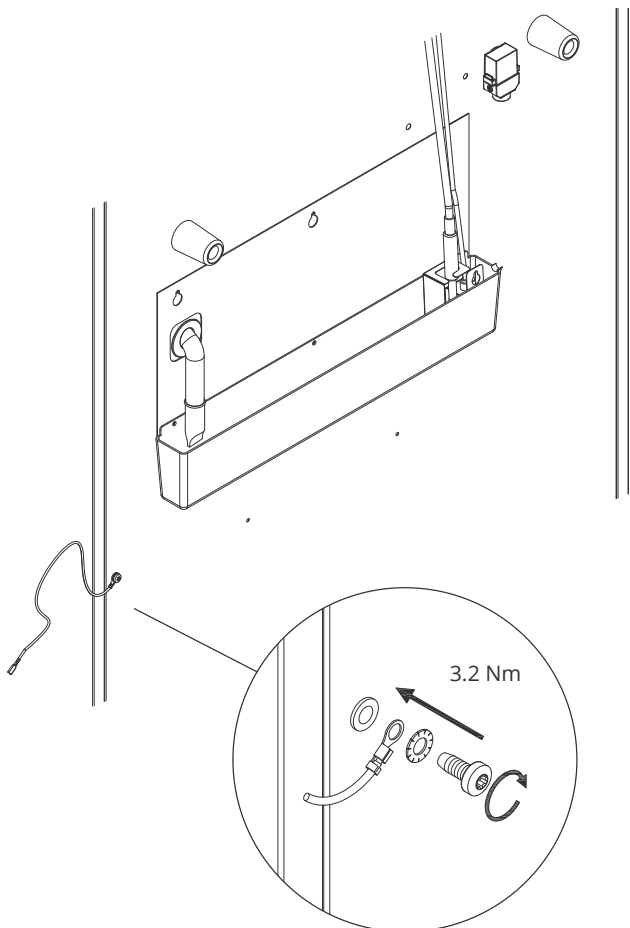

The following part describes the two digital displays for the ExGuard

The ExGuard has two functions and therefore two digital displays as shown below.

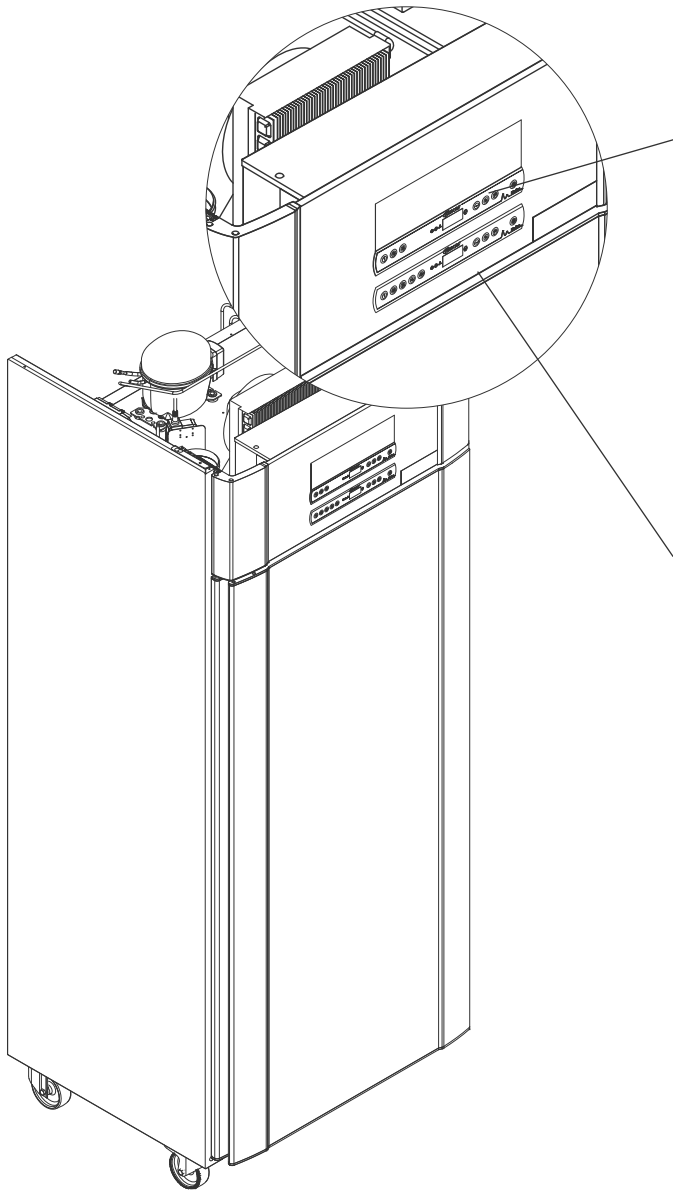

## Extraction controller



The digital display for the extraction system is placed at the top of the digital display and has three keys on the left side of the display (7 keys in total).

Please see page 36 regarding details on the use and setting of the extraction system.

## Operation controller



The lower display is the interface for operating the refrigerator's functions and settings. This digital display has five keys on the left side of the display.

Please, see page 18 regarding for details on the use and setting of the refrigeration system and alarms.

# Start-up – conventional operation

## The digital display (9 keys)

The digital display depicted below, shows the cabinets temperature and indicates if the cabinet is connected to a power source. The following chapter explains the conventional operation of the cabinet and alarms for temperature, door etc.

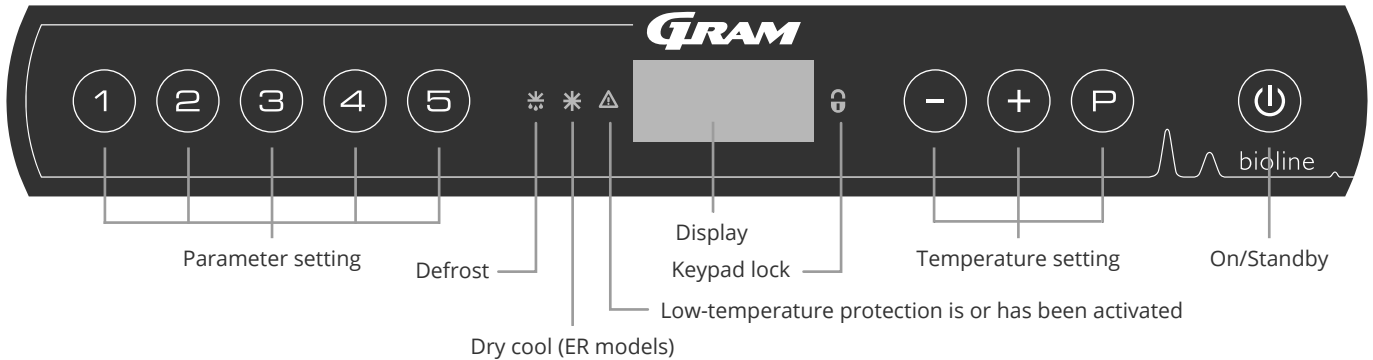

### O-1\*: On/Standby

Press to turn the cabinet On. Press for 6 seconds to switch to standby. The software version of the cabinet will be shown when turning the cabinet on, followed by the software variant and a display test.

The cabinet is ready when the temperature is displayed. The cabinet will automatically start a defrost-cycle when turned on, and terminate it again after a system check.

The cabinet will always commence operation when initially connected to a power supply. For instance after a power outage or when plugging the cabinet in for the first time.

- **Parameter setting**  
Gives access to the cabinet's configurable parameters.
- **Defrost**  
Defrost in progress.
- **Dry cool**  
Dry cool in progress (ER-models).
- **Keypad lock**  
Keypad is locked, no access to functions or menus.
- **Temperature setting**  
Setting of the temperature setpoint and navigation in the menus.
- **On/Standby**  
Turn the cabinet on or switch to standby, and navigation in the menus.

### - ATTENTION -



Make sure the appliance is switched off at the socket before service is performed on electrical parts. It is not sufficient to switch the cabinet to standby on the key, as current will persist in some electrical parts of the cabinet.

### - WARNING -



DO NOT OPEN, MAINTAIN OR SERVICE IN AN AREA WHEN AN EXPLOSIVE ATMOSPHERE IS PRESENT

### - ATTENTION -



High and low temperature alarms set up in the cabinet's controller (including EAL alarms) must be accompanied.

### O-2\*: Temperature setting

Temperature adjustments are done by holding and pressing either or . Confirm the settings by letting go of the keys.

#### All-round introduction to navigating the menus

Beyond setting the temperature and On/Standby, , , and are used to navigate the menus and set the parameters of the cabinet.

The keys have the following functions in the menu:

- Open a menu step or confirm a set value in the parameter settings.
- Scroll upwards in a given menu or raise a given value in parameter settings (alarm setpoint for instance).
- Scroll downwards in a given menu or lower a given value in parameter settings.
- Go back a step in the menu

## Walkthrough of menu

The menu below gives a quick overview of the parameter settings for the cabinet.

### User menu

Menu access	Ⓟ + ① →	↓	→	
		dC		Dry cooling - dC - [HO=Off/H1= On].
Local alarm settings		LAL	LhL	[° C] Upper alarm limit. Code for activated alarm [A2]
			LLL	[° C] Lower alarm limit. Code for activated alarm [A3]
			Lhd	[min.] Delay of upper alarm limit
			LLd	[min.] Delay of lower alarm limit
			dA	On/Off Door alarm. Code for activated alarm [A1]. [1=On/0=Off]
			dAd	[min.] Delay of local door alarm
			BU	On/Off Acoustic signal for alarm codes [A1], [A2] and [A3]. [1=On/0=Off]
External alarm settings		EAL	EhL	[° C] Upper alarm limit. Code for activated alarm [A4]
			ELL	[° C] Lower alarm limit. Code for activated alarm [A5]
			Ehd	[min.] Delay of upper alarm limit
			ELd	[min.] Delay of lower alarm limit
			dA	On/Off Door alarm. Code for activated alarm [A1]. [1=On/0=Off]
			dAd	[min.] Delay of external door alarm
			BU	On/Off Acoustic signal for external alarm codes [A1], [A4], [A5]. [1=On/0=Off]
Offset of sensors		cAL	cA	[° K] Offset of A-sensor. Reference sensor for the refrigeration system
			cE	[° K] Offset of E-sensor. Reference sensor for the display and alarms
		ALL		Activation of escorted alarm limits. [FAS]= locked limits/[ESC] = follows setpoint
		dEF		Number of defrosts per 24 hours (4 is factory setting)
		dPS		Reference sensor for the display (A, E or F) (E is factory setting)

### Other shortcuts

Keys	Duration	Function
Ⓟ + Ⓞ	> 3 seconds	Start or stop a defrost
Ⓞ + ①	> 6 seconds	Activating/deactivating the keypad lock
Ⓟ	-	Shows the temperature setpoint value
+	-	Shows the highest registered temperature spike (since the last reset of the alarm history)
-	-	Shows the lowest registered temperature spike (since the last reset of the alarm history)
+ + -	> 3 seconds	Clear and reset the alarm history
Ⓟ + ① + ③	> 6 seconds	Reset of the set parameters. Restores factory settings
Ⓟ + ①	> 3 seconds	Access to the user menu and the alarm settings

## Error codes

The following table covers the different error codes that might occur.

Display code	Explanation
- 0 -	Door is open.
[A1]	Door alarm "dAd" from LAL and/or EAL has been activated.
[A2]	Local upper alarm LhL is or has been activated.
[A3]	Local lower alarm LLL is or has been activated.
[A4]	External upper alarm EhL is or has been activated.
[A5]	External lower alarm ELL is or has been activated.
F1	Error on sensor for refrigeration system. The refrigeration system will use an emergency program to make the cabinet run. Temperature stability will be affected. Service is required.
F2	Error on the evaporator sensor. Service is required.
F3	Error on the condenser sensor. Service is required.
F4	Error on the 2. condenser sensor. Service is required.
F5	Error on sensor for display and alarm. Service is required.
F7	F7 indicates that the temperature of the condenser is too high. Turn Off the cabinet and check that the condenser is not covered by undesirable items, and insure that the condenser (and possibly filter) is clean. Service is required if the problem is not alleviated.

## Acknowledge an acoustic alarm

Acknowledge a door alarm: [A1] Flashes in the display. Press  $\text{P}$  to acknowledge.

Acknowledge a temperature alarm: [A2, A3] Flashes in the display. Press  $\text{P}$  to acknowledge.

The display will continue to flash if the temperature is outside the alarm limits, and will continue until the temperature has recovered.

## Reading the alarm history – Example [A2]

- [A2] Flashes in the display – This means that the temperature has exceeded the set value for the upper temperature limit, LhL.
- Press  $\text{P}$  to cancel the [A2]. The display continues to flash, indicating that there is information in the alarm history.
- Press  $\text{+}$ , Htt (High temperature time) is shown. Press  $\text{P}$  to see for how long the temperature was above the set alarm limit.
- Press  $\text{⏪}$  to return to Htt. Press  $\text{+}$  to reach Ht (Highest temperature).
- Press  $\text{P}$  to read the highest recorded temperature during "Htt".
- Press  $\text{⏪}$  to return to Ht and press  $\text{⏪}$  again to leave the alarm history function.

The procedure for reading an [A3] alarm is identical, apart from entering the alarm history with  $\text{-}$ .

When reading out temperatures below set limits, the parameters are Ltt and Lt.

A flashing display with no alarm codes indicates that the alarm codes have been cancelled, but the alarm history contains information.

## Dry cool

*The following part covers activation/deactivation of the dry cool feature.*

### dC – Setting the dry cool feature

- ↳ Press and hold  $\text{P}$  +  $\text{1}$  for more than 3 seconds
- ↳ Press  $\text{P}$  to choose “dC”
- ↳ Press  $\text{+}$  or  $\text{-}$  to choose between [H1= Off] [H0=On]
- ↳ Press  $\text{P}$  to confirm
- ↳ Leave the user menu by pressing  $\text{P}$ , press several times until the cabinet's temperature is shown in the display.

**Please note:** The dry cool feature reduces the relative humidity in the cabinet, but does not control it. The activation of the dry cool feature can cause greater fluctuations in the cabinet temperature during defrost.

# Local alarm settings

## Local high alarm Local low alarm

The following part covers the setting of the upper and lower temperature alarm limits.

### O-3\*: LhL – Setting the upper alarm limit [° C]

- ↳ Press and hold (P) + (1) for more than 3 seconds
- ↳ Press (+) to proceed to "LAL"
- ↳ Press (P) to select "LAL". "LhL" is now shown in the display
- ↳ Press (P) to select "LhL". The upper alarm limit is now shown in the display
- ↳ Press (+) or (-) to set the desired value for the upper alarm limit
- ↳ Press (P) to confirm the set value
  - The upper alarm limit is now set, proceed to other parameters by pressing (⏻), then navigate by using (+) or (-)
- ↳ Leave the user menu by pressing (⏻) several times until the cabinet's temperature is shown in the display

### O-4\*: LLL – Setting the lower alarm limit [° C]

- ↳ Press and hold (P) + (1) for more than 3 seconds
- ↳ Press (+) to proceed to "LAL"
- ↳ Press (P) to select "LAL". "LhL" is now shown in the display
- ↳ Press (+) to proceed to "LLL"
- ↳ Press (P) to select "LLL". The lower alarm limit is now shown in the display
- ↳ Press (+) or (-) to set the desired value for the lower alarm limit
- ↳ Press (P) to confirm the set value
  - The lower alarm limit is now set, proceed to other parameters by pressing (⏻), then navigate by using (+) or (-)
- ↳ Leave the user menu by pressing (⏻) several times until the cabinet's temperature is shown in the display



#### - ATTENTION -

High and low temperature alarms set up in the cabinet's controller (including EAL alarms) must be accompanied by additional redundant independent external alarms to ensure maximum item safety.

## Local high alarm delay Local low alarm delay

The following part covers the setting of the delay for the local upper and lower temperature alarm limits.

### O-5\*: Lhd – Setting the delay of the local upper alarm limit [min.]

- ↳ Press and hold  $\text{P} + \text{1}$  for more than 3 seconds
- ↳ Press  $\text{+}$  to proceed to "LAL"
- ↳ Press  $\text{P}$  to select "LAL". "LhL" is now shown in the display
- ↳ Press  $\text{+}$  several times until "Lhd" is shown in the display
- ↳ Press  $\text{P}$  to select "Lhd". The delay of the upper alarm limit is now shown in the display
- ↳ Press  $\text{+}$  or  $\text{-}$  to set the desired value for the delay of the upper alarm limit
- ↳ Press  $\text{P}$  to confirm the set value
  - The delay of the upper alarm limit is now set, proceed to other parameters by pressing  $\text{P}$ , then navigate by using  $\text{+}$  or  $\text{-}$
- ↳ Leave the user menu by pressing  $\text{P}$  several times until the cabinet temperature is shown in the display

### O-6\*: LLd – Setting the delay of the local lower alarm limit [min.]

- ↳ Press and hold  $\text{P} + \text{1}$  for more than 3 seconds
- ↳ Press  $\text{+}$  to proceed to "LAL"
- ↳ Press  $\text{P}$  to select "LAL". "LhL" is now shown in the display
- ↳ Press  $\text{+}$  several times until "LLd" is shown in the display
- ↳ Press  $\text{P}$  to select "LLd". The delay of the lower alarm limit is now shown in the display
- ↳ Press  $\text{+}$  or  $\text{-}$  to set the desired value for the delay of the lower alarm limit
- ↳ Press  $\text{P}$  to confirm the set value
  - The delay of the lower alarm limit is now set, proceed to other parameters by pressing  $\text{P}$ , then navigate by using  $\text{+}$  or  $\text{-}$
- ↳ Leave the user menu by pressing  $\text{P}$  several times until the cabinet temperature is shown in the display



#### - ATTENTION -

High and low temperature alarms set up in the cabinet's controller (including EAL alarms) must be accompanied by additional redundant independent external alarms to ensure maximum item safety.

## On/Off local door alarm Delay for local door alarm

The following part covers the setting of the door alarm and the delay of the door alarm.

### O-7\*: dA – Activate/deactivate of local door alarm

- ↳ Press and hold  $\text{P} + \text{1}$  for more than 3 seconds
- ↳ Press  $\text{+}$  to proceed to "LAL"
- ↳ Press  $\text{P}$  to select "LAL". "LhL" is now shown in the display
- ↳ Press  $\text{+}$  several times until "dA" is shown in the display
- ↳ Press  $\text{P}$  to select "dA"
- ↳ Press  $\text{+}$  or  $\text{-}$  to activate/deactivate the local door alarm [1 = activated/0 = deactivated]
- ↳ Press  $\text{P}$  to confirm the set value
  - The local door alarm is now configured, proceed to other parameters by pressing  $\text{P}$ , then navigate by using  $\text{+}$  or  $\text{-}$
- ↳ Leave the user menu by pressing  $\text{P}$  several times until the cabinet's temperature is shown in the display

### O-8\*: dAd – Setting the delay of the local door alarm [min.]

- ↳ Press and hold  $\text{P} + \text{1}$  for more than 3 seconds
- ↳ Press  $\text{+}$  to proceed to "LAL"
- ↳ Press  $\text{P}$  to select "LAL". "LhL" is now shown in the display
- ↳ Press  $\text{+}$  several times until "dAd" is shown in the display
- ↳ Press  $\text{P}$  to select "dAd". The delay of the local door alarm is now shown in the display
- ↳ Press  $\text{+}$  or  $\text{-}$  to set the desired value for the delay of the local door alarm
- ↳ Press  $\text{P}$  to confirm the set value
  - The delay of the local door alarm is now configured, proceed to other parameters by pressing  $\text{P}$ , then navigate by using  $\text{+}$  or  $\text{-}$
- ↳ Leave the user menu by pressing  $\text{P}$  several times until the cabinet's temperature is shown in the display



#### - ATTENTION -

High and low temperature alarms set up in the cabinet's controller (including EAL alarms) must be accompanied by additional redundant independent external alarms to ensure maximum item safety.

## Local acoustic settings

The following part covers the setting of the acoustic local alarms.

### O-9\*: BU – Activation/deactivation of the acoustic local alarms

- ↳ Press and hold  $\text{P} + \text{1}$  for more than 3 seconds
- ↳ Press  $\text{+}$  to proceed to "LAL"
- ↳ Press  $\text{P}$  to select "LAL". "LhL" is now shown in the display
- ↳ Press  $\text{+}$  several times until "BU" is shown in the display
- ↳ Press  $\text{P}$  to select "BU"
- ↳ Press  $\text{+}$  or  $\text{-}$  to activate/deactivate the local acoustic alarms [1 = activated/0 = deactivated]
- ↳ Press  $\text{P}$  to confirm the set value
  - The local acoustic alarms is configured, proceed to other parameters by pressing  $\text{P}$ , then navigate by using  $\text{+}$  or  $\text{-}$
- ↳ Leave the user menu by pressing  $\text{P}$  several times until the cabinet's temperature is shown in the display



#### - ATTENTION -

High and low temperature alarms set up in the cabinet's controller (including EAL alarms) must be accompanied by additional redundant independent external alarms to ensure maximum item safety.

# External alarm settings

## External high alarm External low alarm

The following part covers the setting of upper and lower external temperature alarm limits.

### O-10\*: EhL – Setting the external upper alarm limit [° C]

- ↳ Press and hold (P) + (1) for more than 3 seconds
- ↳ Press (+) several times until "EAL" is shown in the display
- ↳ Press (P) to select "EAL". "EhL" is now shown in the display
- ↳ Press (P) to select "EhL". The external upper alarm limit is now shown in the display
- ↳ Press (+) or (-) to set the desired value for the external upper alarm limit
- ↳ Press (P) to confirm the set value
  - The external upper alarm limit is now set, proceed to other parameters by pressing (⏏), then navigate by using (+) or (-)
- ↳ Leave the user menu by pressing (⏏) several times until the cabinet's temperature is shown in the display

### O-11\*: ELL – Setting the external lower alarm limit [° C]

- ↳ Press and hold (P) + (1) for more than 3 seconds
- ↳ Press (+) several times until "EAL" is shown in the display
- ↳ Press (P) to select "EAL". "EhL" is now shown in the display
- ↳ Press (+) to proceed to "ELL"
- ↳ Press (P) to select "ELL". The external lower alarm limit is now shown in the display
- ↳ Press (+) or (-) to set the desired value for the external lower alarm limit
- ↳ Press (P) to confirm the set value
  - The external lower alarm limit is now set, proceed to other parameters by pressing (⏏), then navigate by using (+) or (-)
- ↳ Leave the user menu by pressing (⏏) several times until the cabinet's temperature is shown in the display



#### - ATTENTION -

High and low temperature alarms set up in the cabinet's controller (including EAL alarms) must be accompanied by additional redundant independent external alarms to ensure maximum item safety.

## External high alarm delay External low alarm delay

The following parts covers the setting of the delay of the external upper and lower alarms.

### O-12\*: Ehd – Setting the delay of the external upper alarm limit [min.]

- ↳ Press and hold **(P)** + **(1)** for more than 3 seconds
- ↳ Press **(+)** to proceed to "EAL"
- ↳ Press **(P)** to select "EAL". "EhL" is now shown in the display
- ↳ Press **(+)** several times until "Ehd" is shown in the display
- ↳ Press **(P)** to select "Ehd". The external delay of the upper alarm limit is now shown in the display
- ↳ Press **(+)** or **(-)** to set the desired value for the external delay of the upper alarm limit
- ↳ Press **(P)** to confirm the set value
  - The delay of the external upper alarm limit is now set, proceed to other parameters by pressing **(⏻)**, then navigate by using **(+)** or **(-)**
- ↳ Leave the user menu by pressing **(⏻)** several times until the cabinet's temperature is shown in the display

### O-13\*: ELd – Setting the delay of the external lower alarm limit [min.]

- ↳ Press and hold **(P)** + **(1)** for more than 3 seconds
- ↳ Press **(+)** to proceed to "EAL"
- ↳ Press **(P)** to select "EAL". "EhL" is now shown in the display
- ↳ Press **(+)** several times until "ELd" is shown in the display
- ↳ Press **(P)** to select "ELd". The delay of the external lower alarm limit is now shown in the display
- ↳ Press **(+)** or **(-)** to set the desired value for the delay of the lower alarm limit
- ↳ Press **(P)** to confirm the set value
  - The delay of the external lower alarm limit is now set, proceed to other parameters by pressing **(⏻)**, then navigate by using **(+)** or **(-)**
- ↳ Leave the user menu by pressing **(⏻)** several times until the cabinet's temperature is shown in the display



#### - ATTENTION -

High and low temperature alarms set up in the cabinet's controller (including EAL alarms) must be accompanied by additional redundant independent external alarms to ensure maximum item safety.

# On/Off external door alarm

The following parts covers the setting and delay of the external door alarm.

## O-14\*: dA – Activation/deactivation of external door alarm

- ↳ Press and hold (P) + (1) for more than 3 seconds
- ↳ Press (+) to proceed to "EAL"
- ↳ Press (P) to select "EAL". "EhL" is now shown in the display
- ↳ Press (+) several times until "dA" is shown in the display
- ↳ Press (P) to select "dA"
- ↳ Press (+) or (-) to activate/deactivate the external door alarm [1 = activated/0 = deactivated]
- ↳ Press (P) to confirm the set value
  - The external door alarm is now configured, proceed to other parameters by pressing (P), then navigate by using (+) or (-)
- ↳ Leave the user menu by pressing (P) several times until the cabinet's temperature is shown in the display



### - ATTENTION -

High and low temperature alarms set up in the cabinet's controller (including EAL alarms) must be accompanied by additional redundant independent external alarms to ensure maximum item safety.

## External door alarm delay

### O-15\*: dAd – Setting the delay of the external door alarm [min.]

- ↳ Press and hold  $\text{P}$  +  $\text{1}$  for more than 3 seconds
- ↳ Press  $\text{+}$  to proceed to "EAL"
- ↳ Press  $\text{P}$  to select "EAL". "EhL" is now shown in the display
- ↳ Press  $\text{+}$  several times until "dAd" is shown in the display
- ↳ Press  $\text{P}$  to select "dAd". The delay of the external door alarm is now shown in the display
- ↳ Press  $\text{+}$  or  $\text{-}$  to set the desired value for the delay of the external door alarm
- ↳ Press  $\text{P}$  to confirm the set value
  - The delay of the external door alarm is now configured, proceed to other parameters by pressing  $\text{P}$ , then navigate by using  $\text{+}$  or  $\text{-}$
- ↳ Leave the user menu by pressing  $\text{P}$  several times until the cabinet's temperature is shown in the display



#### - ATTENTION -

High and low temperature alarms set up in the cabinet's controller (including EAL alarms) must be accompanied by additional redundant independent external alarms to ensure maximum item safety.

## External acoustic settings

The following part covers the setting of the acoustic external alarms.

### O-16\*: BU – Activation/deactivation of the acoustic external alarms

- ↳ Press and hold (P) + (1) for more than 3 seconds
- ↳ Press (+) to proceed to "EAL"
- ↳ Press (P) to select "EAL". "EhL" is now shown in the display
- ↳ Press (+) several times until "BU" is shown in the display
- ↳ Press (P) to select "BU"
- ↳ Press (+) or (-) to activate/deactivate the external acoustic alarms [1 = activated/0 = deactivated]
- ↳ Press (P) to confirm the set value
  - The external acoustic alarms is configured, proceed to other parameters by pressing (⏪), then navigate by using (+) or (-)
- ↳ Leave the user menu by pressing (⏩) several times until the cabinet's temperature is shown in the display



#### - ATTENTION -

High and low temperature alarms set up in the cabinet's controller (including EAL alarms) must be accompanied by additional redundant independent external alarms to ensure maximum item safety.

## Sensor offset

The temperature sensors connected to the controller can be offset independently of each other in the parameter settings cAL.

Offset is used in cases where there are deviations in the cabinet's actual operation compared to the display and/or control measurements by independent temperature monitoring.

The cabinet is equipped with a A-sensor and a E-sensor.

**The A-sensor** is used to manage the cabinet's refrigeration system and is fixated in a given position in the cabinet, not in storage space. The location of the A-sensor must not be altered.

**The A-sensor** should be offset if the actual temperature in the cabinet does not match the setpoint, despite taking the hysteresis into consideration. Offset of A-sensor is named "cA".

**The E-sensor** is placed in the cabinet's storage space and can be moved around in the cabinet to get the desired reference point for temperature. The E-sensor is the default display sensor and reference for the alarms. The E-sensor has no effect on control of the refrigeration system.

**The E-sensor** should be offset if the actual temperature in the cabinet's display, provided that the display sensor for reference is the E-sensor, does not match the independent temperature monitoring used for control. Offset of E-sensor is named "cE".

### Practical example of offset:

#### Example 1

The temperature in the cabinet is operating colder than the actual setpoint.

With a setpoint of +4 °C, the actual temperature inside the cabinet is between +2 and +4 °C. The desired temperature range is between +3 and +5 °C. This means that "cA", in this case, should be -1.0K, so that the refrigeration system stops 1.0K before and starts 1.0K later than the setpoint normally otherwise would dictate.

#### Example 2

The temperature in the cabinet is operating warmer than the actual setpoint.

With a setpoint of +4 °C, the actual temperature inside the cabinet is between +4 and +6 °C. The desired temperature range is between +3 and +5 °C. This means that "cA", in this case, should be 1.0K, so that the refrigeration system stops 1.0K later and starts 1.0K earlier than the setpoint normally otherwise would dictate.

---

## Offset of the A-sensor

- ↳ Press and hold  $\text{P} + \text{1}$  for more than 3 seconds
- ↳ Press  $\text{+}$  several times until "cAL" is shown in the display
- ↳ Press  $\text{P}$  to select "cAL". "cA" is shown in the display
- ↳ Press  $\text{P}$  to select "cA"
- ↳ Press  $\text{+}$  or  $\text{-}$  to offset the A-sensor
- ↳ Press  $\text{P}$  to confirm the set value
  - The A-sensor is now offset, proceed to other parameters by pressing  $\text{U}$ , then navigate by using  $\text{+}$  or  $\text{-}$
- ↳ Leave the user menu by pressing  $\text{U}$  several times until the cabinet's temperature is shown in the display

## Offset of the E-sensor

- ↳ Press and hold  $\text{P} + \text{1}$  for more than 3 seconds
- ↳ Press  $\text{+}$  several times until "cAL" is shown in the display
- ↳ Press  $\text{P}$  to select "cAL". "cA" is shown in the display
- ↳ Press  $\text{+}$  until "cE" is shown in the display
- ↳ Press  $\text{P}$  to select "cE"
- ↳ Press  $\text{+}$  or  $\text{-}$  to offset the E-sensor
- ↳ Press  $\text{P}$  to confirm the set value
  - The E-sensor is now offset, proceed to other parameters by pressing  $\text{U}$ , then navigate by using  $\text{+}$  or  $\text{-}$
- ↳ Leave the user menu by pressing  $\text{U}$  several times until the cabinet's temperature is shown in the display

## Escorted/set alarm limits

*The following part covers the setting of escorted or set alarm limits.*

### ALL – Setting of escorted/set alarm limits

- ↳ Press and hold  $\text{P} + \text{1}$  for more than 3 seconds
- ↳ Press  $\text{+}$  several times until “ALL” is shown in the display
- ↳ Press  $\text{P}$  to select “ALL”
- ↳ Press  $\text{+}$  or  $\text{-}$  to select set or escorted alarm limits
- ↳ Press  $\text{P}$  to confirm the set value
- ↳ Leave the user menu by pressing  $\text{P}$  several times until the cabinet's temperature is shown in the display

“**Set alarm**” is fixed, operating independently from the setpoint. The alarm limits will remain the selected values regardless of the setpoint being altered.

“**Escorted alarm**” is fixed and locked to the setpoint. The alarm limits will change according to the altered setpoint.

## Defrosts/24 hours

The following part covers the setting of the amount of defrosts per 24 hours.

### O-17\*: dEF – Number of defrosts

- ↳ Press and hold (P) + (1) for more than 3 seconds
- ↳ Press (+) several times until “dEF” is shown in the display
- ↳ Press (P) to select “dEF”
- ↳ Press (+) or (-) to set the desired amount of defrosts per 24 hours (factory setting is 4)
- ↳ Press (P) to confirm the set value
- ↳ Leave the user menu by pressing (⏻) several times until the cabinet's temperature is shown in the display



#### - ATTENTION -

It is very important that defrosts should not be set to 0 for a prolonged period of time, as this will reduce the cooling capacity of the cabinet.

## Display sensor

The following part covers the setting of which sensor to be shown in the display.

### O-18\*: dPS – Selection of reference sensor for the display

- ↳ Press and hold **(P)** + **(1)** for more than 3 seconds
- ↳ Press **(+)** several times until “dPS” is shown in the display
- ↳ Press **(P)** to select “dPS”
- ↳ Press **(+)** or **(-)** to select either the A- or E-sensor
- ↳ Press **(P)** to confirm the set value
- ↳ Leave the user menu by pressing **(⏪)** several times until the cabinet's temperature is shown in the display



**Please note:**

The dPS only changes the reference sensor for the display, and not the reference sensor for the alarms. The reference sensor for the refrigeration system is the A-sensor, this cannot be altered.

# Start-up

## The digital display (7 keys)

The digital display depicted below, shows the ExGuard's door lock and extraction system and indicates if the cabinet is connected to a power source.

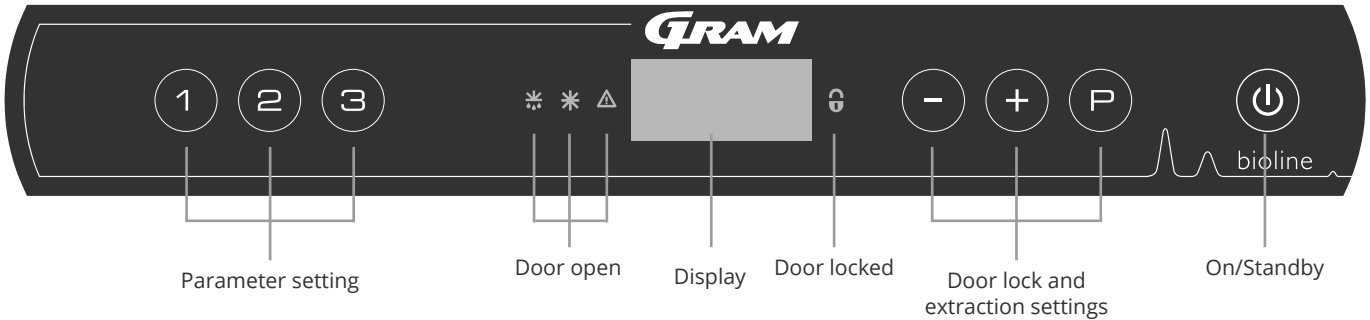

### All-round introduction to navigating the menus for the extraction system

Beyond setting the door lock and extraction system and On/Standby, (P), (+), (-) and (⏪) is used to navigate the menu and set the parameters of the ExGuard.

The keys have the following functions in the menu:

- (P) Open a menu step or confirm a set value in the parameter settings.
- (+) Scroll upwards in a given menu or raise a given value in parameter settings (alarm setpoint for instance).
- (-) Scroll downwards in a given menu or lower a given value in parameter settings.
- (⏪) Go back a step in the menus. The key has no other function than return when operating the menu.

The cabinet is ready when the temperature is displayed. During start-up and operation the display is blank, unless extraction process or alarms are activated or the menu is entered.

- Parameter setting**  
Gives access to the ExGuard's configurable parameters for the door lock and extraction system.
- Door open**  
Green LEDs indicate that the door lock is released.
- Display**  
Indicates status of the door lock and extraction system when it is activated and shows menu points when navigating with right side digits (-,+ og P). If the menu is not active the display is blank.
- Door locked**  
Red LED indicates that the door lock is active.
- Door lock and extraction settings**  
Setting of the door lock and extraction setpoints and navigation in the menus.
- On/Standby**  
Used for navigation in the menus.



### - WARNING -

DO NOT OPEN, MAINTAIN OR SERVICE IN AN AREA WHEN AN EXPLOSIVE ATMOSPHERE IS PRESENT



### - ATTENTION -

Make sure the appliance is switched Off at the socket before service is performed on electrical parts. It is not sufficient to switch to switch the cabinet to standby on the (⏪) key, as current will persist in some electrical parts of the cabinet.

## Walkthrough of menu

The menu below gives an overview of the parameter settings for the ExGuard's door lock and extraction system

### User menu

Menu Access (P) + (2) →	↓		
Damper open time	dot	[Seconds]	The time the damper must be open before the electronic door lock opens and the damper can return to closed position.
Feedback sensor	FbS	5 = 5k Ω 10 = 10 kΩ	Feedback potentiometer type: either a 10.000 ohms solution or 5.000 ohms solution. Default value is 5.
Feedback sensor active (*)	FbA	[0,1,2]	On/Off by the feedback potentiometer. In the Off position there is no monitoring for the alarm codes [A10], [A11], [A12] and [A13].
Door lock open	dLo	[Seconds]	Time until door-opening is possible.
Door alarm	dA	[0, 1]	Turns on the door alarm via the reed-switch. In the Off position there is no monitoring on the door and for the alarm codes [A20] and [A21].
Door alarm delay	dAd	[Seconds]	Door delay time.
Extraction alarm	EUA	On/Off	N/A
Extraction extra	EUE	[Seconds]	An additional extraction of the chemical cabinet, in case the door is not closed properly.
Periodic extraction	PE	[0-24 h]	Number of automatic extractions/flushings of the storage chamber per 24 hours. Factory setting = 4.
Buzzer	BU	On/Off	Buzzer On/Off.

### \*) Explanation of FbA

Value	Sensor	Explanation of the FbA points
0	Off	Function is deactivated.
1	On	Monitoring of damper – No short circuit and cable breakage control.
2	On	Monitoring of dampers – With short circuit and cable breakage control.

### Other shortcuts

Keys	Duration	Function
(P) + (2)	3 seconds	Access to the user menu and the alarm settings.

## Error codes

*The following table covers the different error codes that might occur for the ExGuard.*

The extraction system monitors multiple error types. In case of errors, these are shown on the display. In the case of alarms, ensure the door is closed.

Due to user and environmental safety concerns, alarms relating to the extraction system cannot be reset. Additionally the door opening procedure cannot be initiated while these alarm conditions persist.

In case of alarms related to the extraction system please contact Gram BioLine service for further support.

Display code	Explanation
[A10]	Damper cannot open
[A11]	Damper cannot close
[A12]	Low resistance – “Short circuit” on the circuit
[A13]	High resistance – “Cable Break” on the circuit
[A20]	Door alarm – Door is not closed properly
[A21]	Door alarm – Sensor fault on the door sensor
[A30]	Insufficient airflow registered in the extraction system
[A31]	Sensor fault in the extraction system

# Opening and closing the door



The following part covers how the door opens and closes upon activation of the door lock.

## Door opening process



When the user needs access to the storage chamber, press ① on the ExGuards digital panel. This starts the extraction process allowing the damper to open, starting the extraction process. Once the extraction is complete, the electromagnetic door lock disengages and allows the door to be opened.

Closing the door reengages the electromagnetic lock. Once the door is closed and electromagnetic door lock has been engaged, the extraction process must be reinitiated to access the storage chamber.

## Extraction process in details

### Opening the door

When closed, the door is locked – Visualised by the red LED to the right of the display.

- ↳ To access the ExGuard storage chamber, press ① on the keypad, initiating extraction of the storage chamber.
- ↳ The display will count down from 100.
- ↳ When the count down reaches 0, the display will show the code: CL (Clear), and gives an audible acknowledgement. Signifying a successful extraction.
- ↳ The red LED turns off, and the three green LEDs on the left start blinking.
- ↳ The door can now be opened. The door lock is disengaged for five seconds.

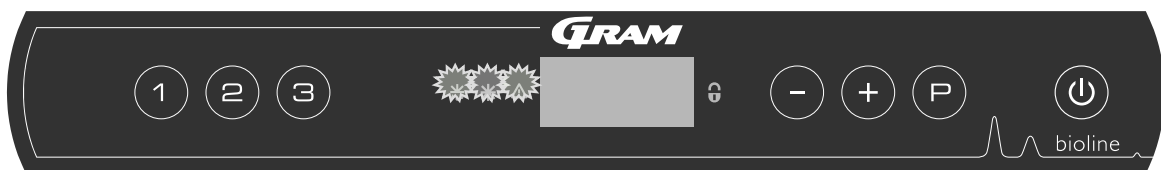
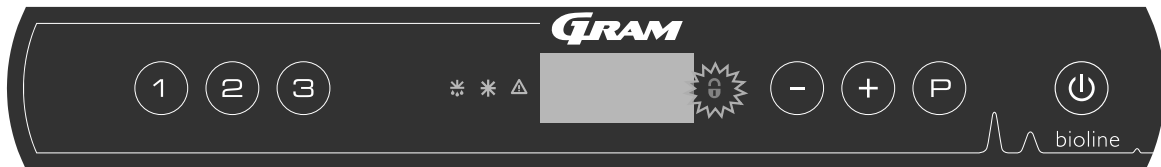

### Closing and locking the door

Five seconds after the green LEDs has started to blink the cabinet reengages the door locking mechanism.

- ↳ Close door.
- ↳ Two short beeps to indicate that the door locking process has begun.
- ↳ CL disappears from the display, the green LEDs turns off and the red LED turns on.
- ↳ A count from 0 to 100 commences. 100 signifying the damper has moved to the closed position.
- ↳ Upon reaching 100 in the count, the display will change to show LO for five seconds.
- ↳ Once the door is closed and the electromagnetic door lock has been engaged, the extraction process must be repeated to access the storage chamber.



Even if the door is open for a longer period of time than the parameter “dLo” is set for, the door-locking process will start after the set time. This ensures that when the door is closed it cannot be re-opened before the extraction process has been repeated.

# Parameter settings

## Damper open time

*The following part covers the adjustments of the dampers opening time.*

### dot – Adjusting the time for how long the damper is open [seconds]

- ↳ Press and hold (P) + (2) for more than 3 seconds
- ↳ dot is now shown in display
- ↳ Press (P) to select "dot". The damper open time is now present in the display
- ↳ Press (-) or (+) to set the desired opening time for the damper [default is 20 seconds]
- ↳ Press (P) to confirm the set value
  - The duration for damper open time is now set, proceed to other parameters by pressing (⏏), then navigate by using (-) or (+)
- ↳ Leave the user menu by pressing (⏏), several times until the display goes back to blank



#### **- WARNING -**

All settings must be based on the intended use and based on EN 60079-10, in order to achieve the correct use and safety for the user and the environment.

## Feedback sensor

### Feedback sensor activation

The following parts covers setting the feedback sensor for the extraction system.

#### FbS – Setting the feedback potentiometer type for the sensor

- ↳ Press and hold (P) + (2) for more than 3 seconds
- ↳ Press (-) to proceed to "FbS"
- ↳ Press (P) to select "FbS". Feedback sensor is now shown in the display
- ↳ Press (-) or (+) to set the sensor feedback [5 = 5k Ω/10 = 10k Ω; Default value is 5]
- ↳ Press (P) to confirm the set value
  - The feedback sensor is now configured, proceed to other parameters by pressing (M), then navigate by using (-) or (+)
- ↳ Leave the user menu by pressing (M) several times until the display goes back to blank

#### FbA – Activation/deactivation and value setting for the feedback sensor

- ↳ Press and hold (P) + (2) for more than 3 seconds
- ↳ Press (-) to proceed to "FbA"
- ↳ Press (P) to select "FbA". Feedback sensor active is now shown in the display.
- ↳ Press (-) or (+) to set the sensor value \* [1-2 = activated/0 = deactivated; Default value is 1]
- ↳ Press (P) to confirm the set value.
  - The feedback sensor is now configured, proceed to other parameters by pressing (M), then navigate by using (-) or (+).
- ↳ Leave the user menu by pressing (M) several times until the display goes back to blank.

#### \* Values for the feedback sensor

Value	Sensor	Explanation of the FbA points
0	Off	Function is deactivated
1	On	Monitoring of damper with no short circuit and cable breakage control
2	On	Monitoring of dampers and with short circuit and cable breakage control



#### - WARNING -

All settings must be based on the intended use and based on EN 60079-10, in order to achieve the correct use and safety for the user and the environment.

## Door lock open time Door alarm activation

The following part covers the timing and setting of the door lock and alarm.

### dLo – Adjusting how long the door lock is open [seconds]

- ↳ Press and hold (P) + (2) or more than 3 seconds
- ↳ Press (-) to proceed to “dLo”
- ↳ Press (P) to select “dLo”. Door Lock open is now shown in the display.
- ↳ Press (-) or (+) to set the time the door lock must be open in increments of +/-1 seconds [Default value is 5 seconds]
- ↳ Press (P) to confirm the set value.
  - The time the door lock must be open is now set, proceed to other parameters by pressing (⏪), then navigate by using (-) or (+)
- ↳ Leave the user menu by pressing (⏩) several times until the display goes back to blank

### dA – Activation/Deactivation of the door alarm

- ↳ Press and hold (P) + (2) for more than 3 seconds
- ↳ Press (-) to proceed to “dA”
- ↳ Press (P) to select “dA”. Door alarm is now present in the display
- ↳ Press (-) or (+) to activate/deactivate the alarm [1 = activated/0 = deactivated; Default value is 1]
- ↳ Press (P) to confirm the set value
  - The door alarm is now configured, proceed to other parameters by pressing (⏪), then navigate by using (-) or (+)
- ↳ Leave the user menu by pressing (⏩) several times until the display goes back to blank



#### - WARNING -

All settings must be based on the intended use and based on EN 60079-10, in order to achieve the correct use and safety for the user and the environment.

## Door alarm delay

*The following part covers the timing and setting of the door lock alarm delay.*

### dAd – Adjusting the delay of the door alarm [seconds]

- ↳ Press and hold  $\text{P}$  +  $\text{2}$  for more than 3 seconds
- ↳ Press  $\text{-}$  to proceed to “dAd”
- ↳ Press  $\text{P}$  to select “dAd”. Door alarm delay is now shown in the display
- ↳ Press  $\text{-}$  or  $\text{+}$  to set the desired delay for the door alarm in increments of +/-5 seconds [Default value is 60 seconds]
- ↳ Press  $\text{P}$  to confirm the set value
  - The door alarm delay is now set, proceed to other parameters by pressing  $\text{U}$ , then navigate by using  $\text{-}$  or  $\text{+}$
- ↳ Leave the user menu by pressing  $\text{U}$  several times until the display goes back to blank



#### **- WARNING -**

All settings must be based on the intended use and based on EN 60079-10, in order to achieve the correct use and safety for the user and the environment.

---

## **Extraction alarm – Not available**

EUA – Activation/deactivation of the extraction alarm – not available

## Extraction extra time Periodic extraction frequency

The following parts covers the adjustment of the extraction timing for the extraction system.

### EUE – Adjusting the extra extraction time [seconds]

- ↳ Press and hold **(P)** + **(2)** for more than 3 seconds
- ↳ Press **(-)** to proceed to “EUE”
- ↳ Press **(P)** to select “EUE”. Extraction extra is now shown in the display
- ↳ Press **(-)** or **(+)** to set the desired extra extraction time in increments of +/-5 seconds [Default value is 120 seconds]
- ↳ Press **(P)** to confirm the set value
  - The extra extraction time is now set, proceed to other parameters by pressing **(U)**, then navigate by using **(-)** or **(+)**
- ↳ Leave the user menu by pressing **(U)** several times until the display goes back to blank



Extra extraction happens when the electromagnet for the door locking system senses that the door is not properly closed and locked. The door locking circuit is a separate system from the door alarm in the cooling system.

### PE – Setting up the periodic extraction frequency

- ↳ Press and hold **(P)** + **(2)** for more than 3 seconds
- ↳ Press **(-)** to proceed to “PE”
- ↳ Press **(P)** to select “PE”. Periodic Extraction is now shown in the display
- ↳ Press **(-)** or **(+)** to set the desired periodic extraction frequency pr. 24 hours. [Default value is 4 pr. 24 hours].
- ↳ Press **(P)** to confirm the set value
  - The periodic extraction frequency is now set, proceed to other parameters by pressing pressing **(U)**, then navigate by using **(-)** or **(+)**
- ↳ Leave the user menu by pressing **(U)** several times until the display goes back to blank

---

## Buzzer

*The following part covers setting of the alarm buzzer On/Off*

### BU – Activation/Deactivation of the alarm buzzer

- ↳ Press and hold  $\text{P}$  +  $\text{2}$  for more than 3 seconds
- ↳ Press  $\text{-}$  to proceed to "BU"
- ↳ Press  $\text{P}$  to select "BU". Buzzer On/Off is now shown in the display
- ↳ Press  $\text{-}$  or  $\text{+}$  to activate/deactivate the buzzer [1 = activated/0 = deactivated; Default value is 1]
- ↳ Press  $\text{P}$  to confirm the set value
  - The buzzer is now configured, proceed to other parameters by pressing  $\text{U}$ , then navigate by using  $\text{-}$  or  $\text{+}$
- ↳ Leave the user menu by pressing  $\text{U}$  several times until the display goes back to blank

The following part shows how items should be placed and stored in the cabinet.

Keep the marked areas in the cabinet (shown on this page) clear of all items, thereby ensuring adequate air circulation, and therein cooling.

Do not place items beneath the lowest shelf bracket. All products to be stored, that are not wrapped or packed, must be covered in order to avoid unnecessary corrosion of the inner parts of the cabinet.

Items placed on the bottom of the cabinet will cause the air circulation to be impeded, which reduces the cabinet's performance.



The items should be evenly distributed in the cabinet, with minimum layer-thickness/maximum surface. And at the same time, the air should be able to circulate freely between the items.

The illustration shows the load height of the cabinet.

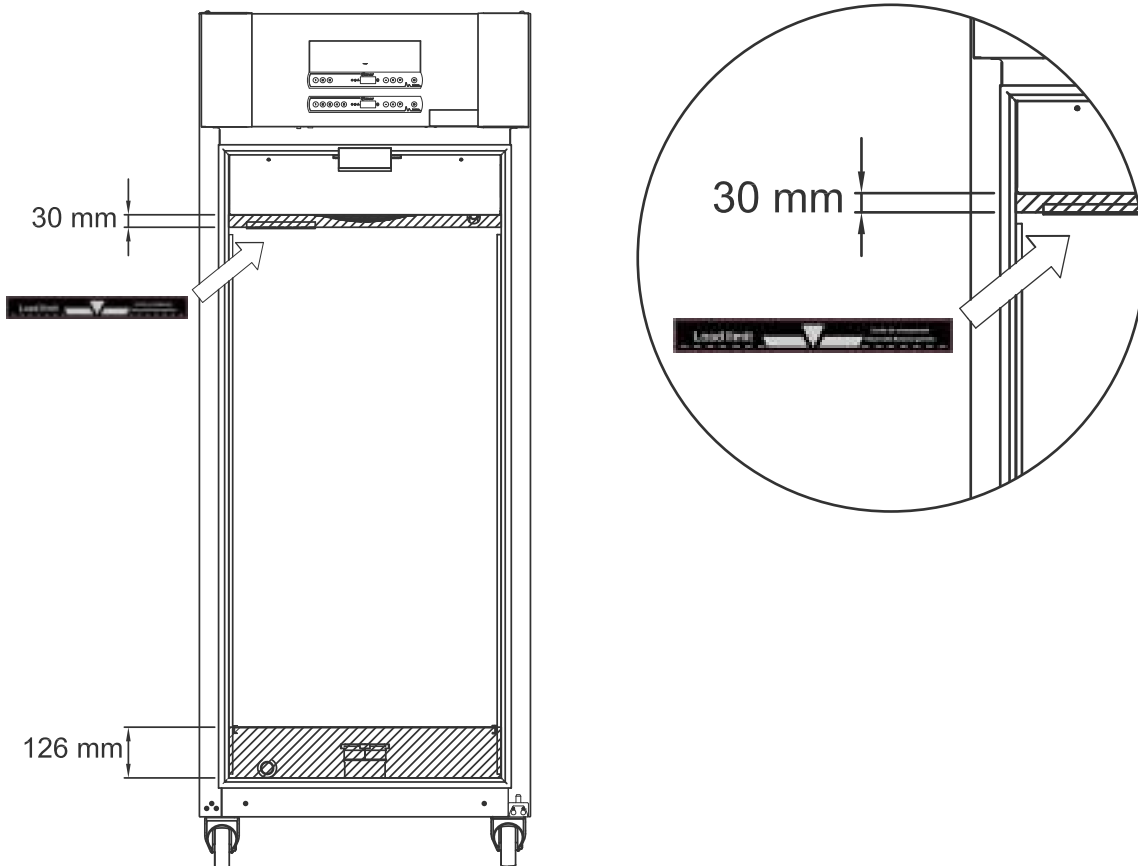

**- IMPORTANT -**



Be aware not to block the extraction ducting in the top and bottom of the cabinet, as this will have serious effects on the cabinet's ability to extract the atmospheres from the cabinet during the extraction process, before opening the door (please see the section "Opening and closing of door"). Items must not come into close proximity to the extraction ducting.

# Regular maintenance

## Cleaning

*Inadequate cleaning can lead to the cabinet not functioning properly or at all.*



The cabinet should be cleaned internally with a mild soap solution (max. 85° C) at suitable intervals and checked thoroughly before it is put into operation again.

Cleaning agents with a pH of  $5 \pm 1$  can be used when a mild soap solution and/or water is used to remove any substance that might damage cabinet components or surfaces. The cleaning agent should be compatible with materials such as steel, alloy, sheet metal, paint, and plastics

Ensure that there is not ingress of contaminants in the valves in the extraction ducting which will impede their function.

The compressor compartment and in particular the condenser must be kept free from dust and dirt. This can be done with a vacuum cleaner and a brush.

The air filters on the condenser and the front panel should be removed and cleaned with warm water (max. 50° C).

It is recommended that the re-evaporation tray is checked regularly for foreign objects and cleaned accordingly.

Do not flush the compressor compartment and evaporator with water as this may cause short-circuits in the electrical system.

Cleaning agents containing chlorine or compounds of chlorine as well as other corrosive agents, may not be used, as they might cause corrosion to the stainless panels of the cabinet and the refrigeration system.

The location of the condenser is illustrated below.

## Door gasket

*The following part covers the importance of a properly functioning door gasket.*

The door gasket is an important part of the cabinet. Impaired door gaskets can lead to increased humidity, iced up evaporator (and thus reduced cooling capacity), and in some cases, decreased longevity of the cabinet.

It is therefore very important to be aware of the door gasket's condition. Regular inspection is recommended.

The door gasket should be cleaned regularly with a mild soap solution.

If a gasket is to be replaced, please contact your local Gram BioLine distributor.

The illustration shows the location of the door gasket.

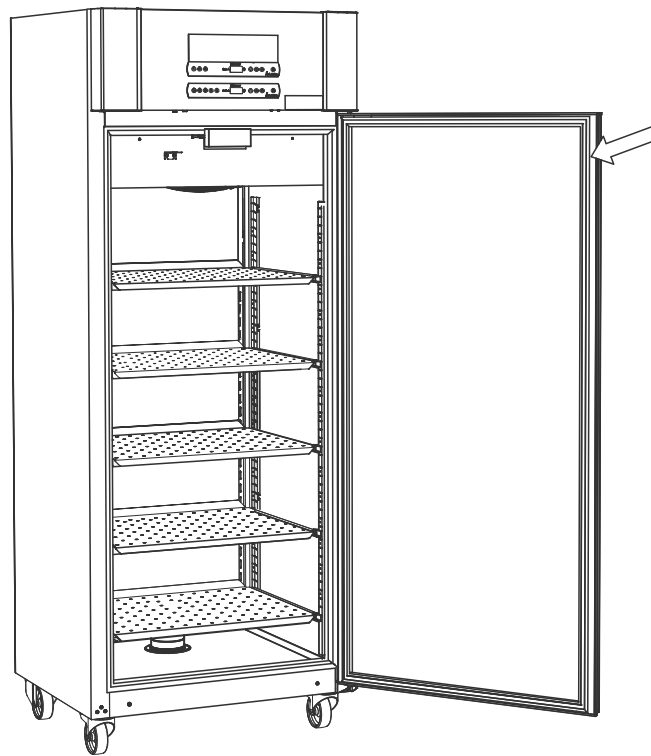

# General info

## Responsibility

Read the following carefully, for information on technical safety and responsibility regarding Gram BioLine products.



**- WARNING -**

DO NOT OPEN, MAINTAIN OR SERVICE IN AN AREA WHEN AN EXPLOSIVE ATMOSPHERE IS PRESENT



When servicing, make sure the appliance is switched off at the socket before service is performed on the cabinet. It is not sufficient to switch the cabinet to standby on the On/Standby  key, as current will persist in some electrical parts of the cabinet.



Warranty may be void in the event of the cabinet being used for applications other than its intended use, or otherwise not in accordance with the guidelines stipulated in the instructions for use.



Defective parts must be replaced with original parts from Gram BioLine. Gram BioLine can only guarantee functional and safety requirements on the cabinets, if above mentioned is adhered to.



The cabinet should be checked at least once yearly by a Gram BioLine authorised technician. The refrigeration system and the hermetically sealed compressor require no maintenance. However the condenser requires regular cleaning.



Be aware that cabinets using hydrocarbons (HC) as refrigerant, may require special handling by qualified technicians.

## Type/number plate

If refrigeration fails, first look to see whether the cabinet has been unintentionally switched off, or whether a fuse has blown.

If the cause of failure cannot be found, contact your supplier quoting type and S/N. This information can be found on the type/number plate.

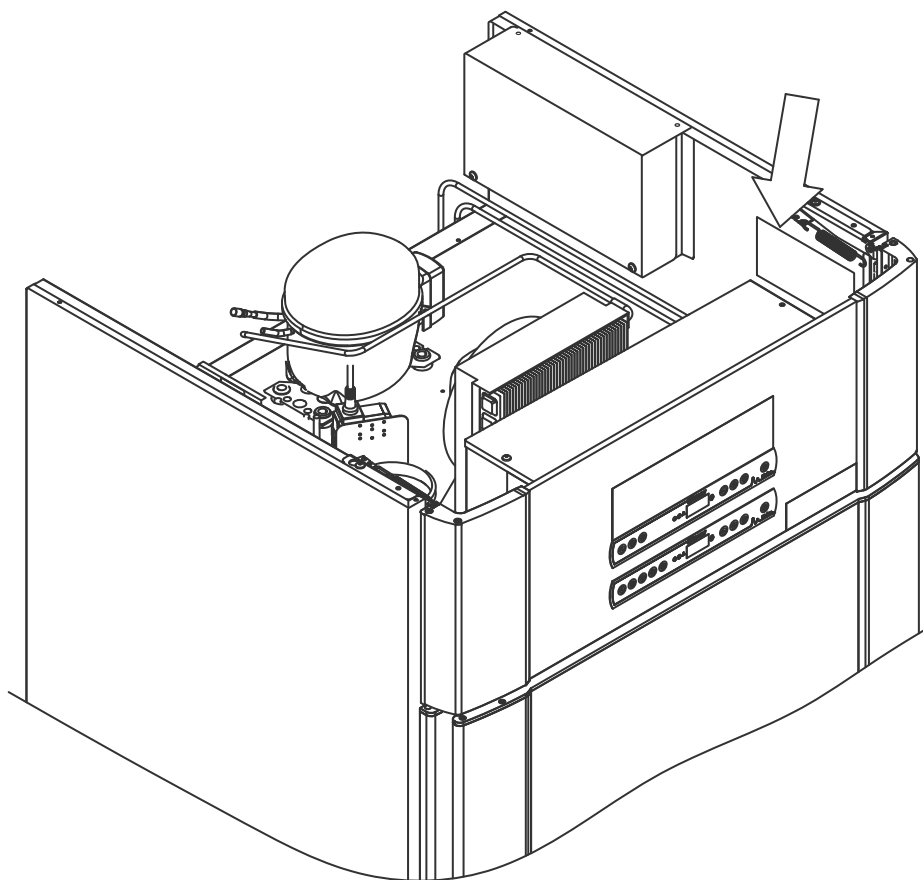

## Defrost water

*The cabinet creates defrost water, that is directed into the re-evaporation tray at the back of the cabinet.*

Defrost water is led through a tube in insulation to a re-evaporation tray at the back of the cabinet.



It is recommended that the re-evaporation tray is checked regularly for foreign objects and cleaned accordingly. This shall only be done while the cabinet is turned off.

Be careful not to damage the defrost water tube and the heating element (located in the tray) when cleaning.

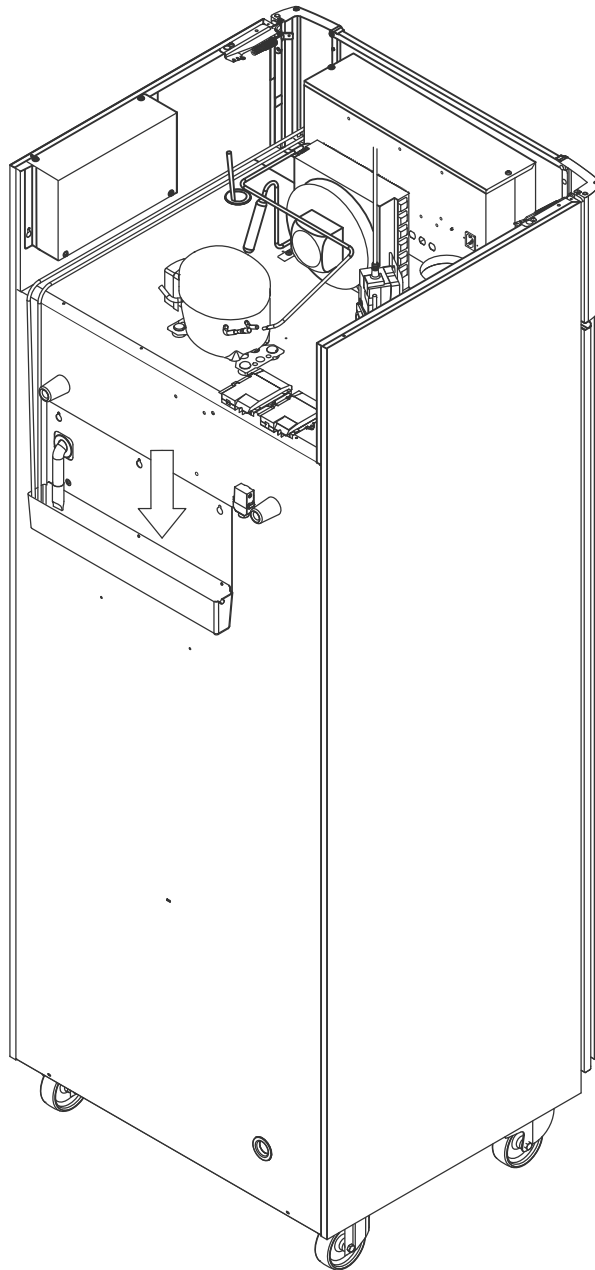

## Door self-closing mechanism

**Please note:** the ExGuard cabinets are equipped with doors that have a door self-closing mechanism

The door is equipped with a door self-closing mechanism. Open the door up to 90°, and it will shut by itself. Open the door more than 90° and door will remain open.



See section “Opening and closing of door” for further details regarding opening and closing of door.

## Door lock

*The ExGuard cabinet is equipped with an electromagnetic safety lock.*

The illustration below shows the safety lock.

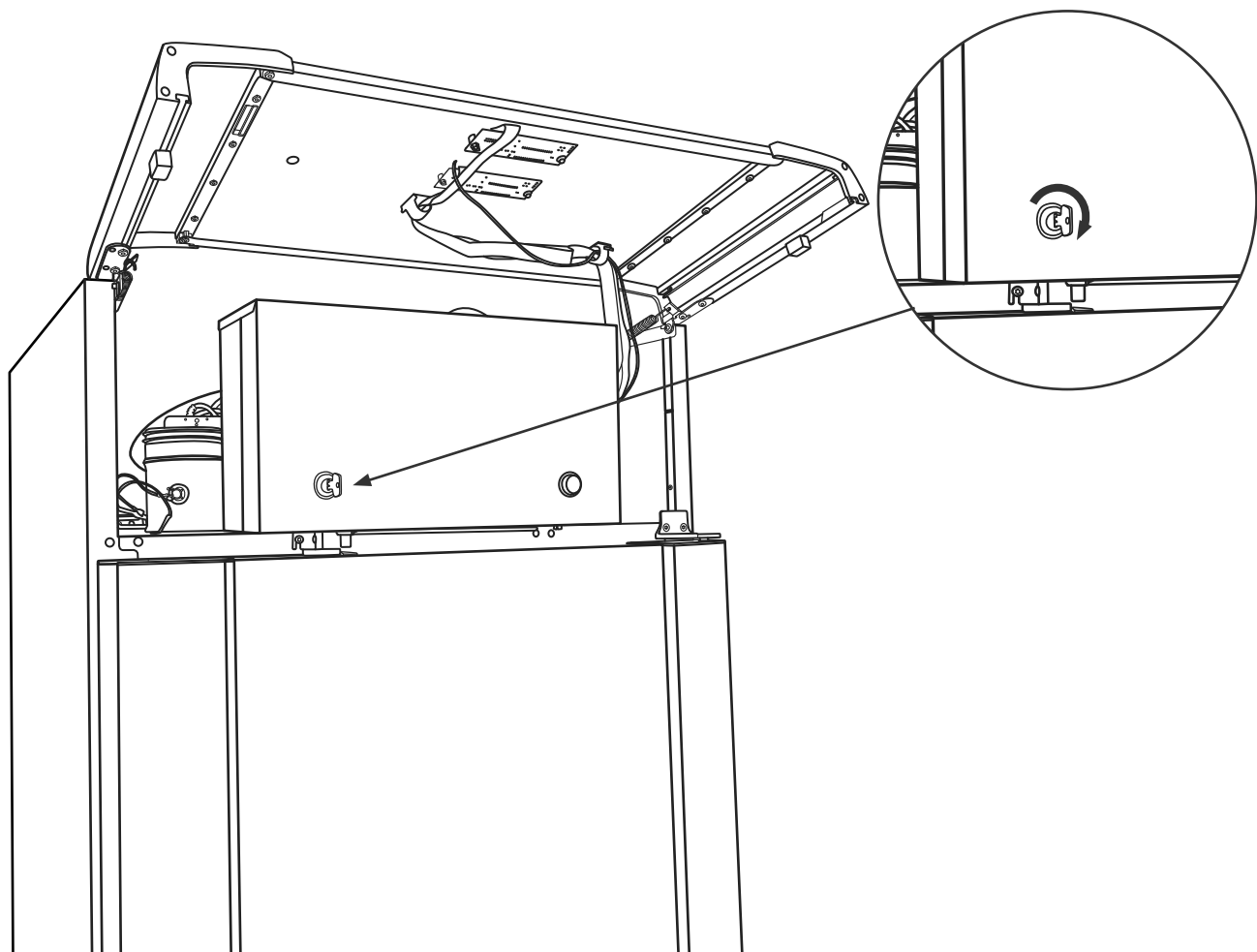

## Access port

All BioLine cabinets are equipped with an access port on the back of the cabinets, this can be used to easily fit external sensors and the like.

The illustration below shows the access port in the ExGuard 600W cabinet. All access ports are constructed in the same fashion, with a conical polystyrene plug (fitted from the back of the cabinet) and a plastic cap (fitted from the inside of the cabinet).



**Please note:**

It is very important to refit the polystyrene plug (position 1) and plastic cap (position 2) after mounting a sensor, probe etc. failing to do so can result in lowered performance or malfunction of the cabinet. Due to the intended use of the ExGuard cabinet, it is critical to ensure a proper seal in the access port.

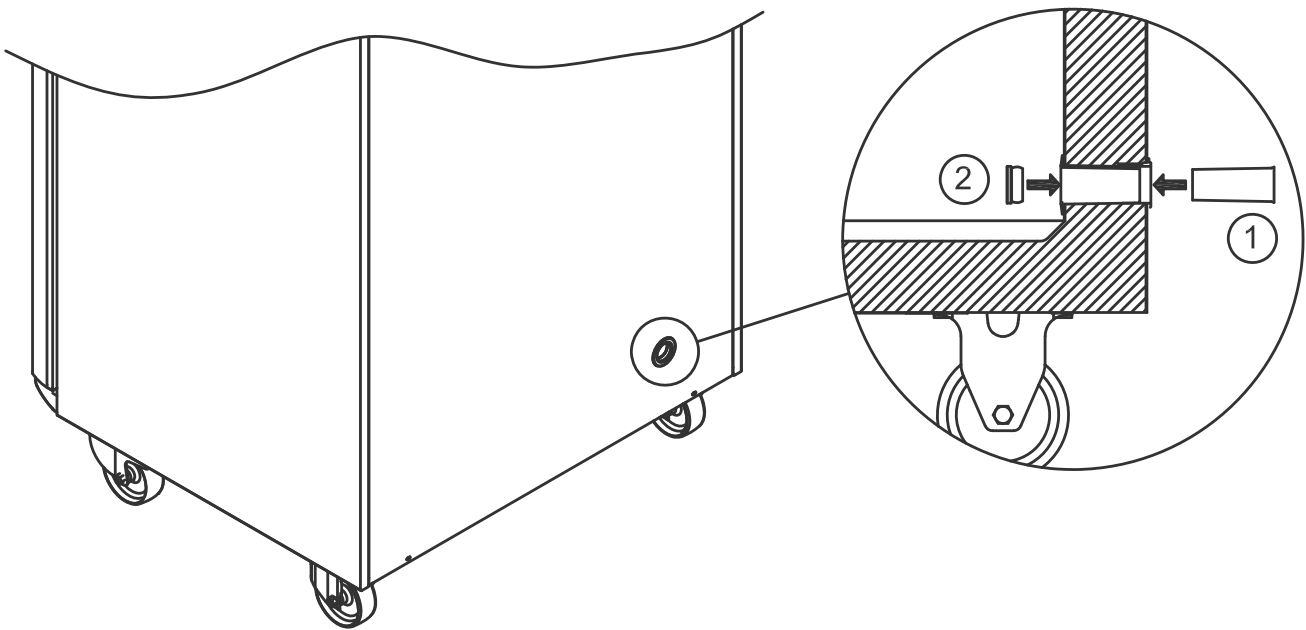

## Important

*In the event of need for product support. Do not hesitate to contact us at: [support@gram-bioline.com](mailto:support@gram-bioline.com)*



### – IMPORTANT –

1. There may be sharp edges on the cabinet housing, compressor room, and interior. Show due diligence when handling the cabinet, negligence of these precautions can lead to injuries.
2. Be cautious about the potential risk of body parts getting wedged in the frame slot between the door and the cabinet when opening or closing the cabinet. Exercise due diligence to avoid any accidents. Failure to take these precautions may result in injuries.
3. Exercise caution to prevent the potential wedging of body parts in the drawer column between the drawers and the interior of the cabinet. Demonstrate due diligence to avoid accidents, as negligence in observing these precautions may lead to injuries.
4. Be aware that the cabinet door is locked magnetically and can only be opened by performing the extraction process. If for any reason a failure or error should occur during this process, **do not attempt repair or remedy the fault, contact Gram BioLine technical support.**
5. Be particularly vigilant in relation to closing doors with self-close mechanism as these are spring-loaded. Negligence of these precautions can lead to injuries.
6. Unlocked castors can lead to unexpected movements of the cabinet. Lock the castors after installation. Negligence of these precautions can lead to injuries.
7. The re-evaporation tray, re-evaporation tray heating element, pressure pipes and compressor develops considerable heat during operation. Assure yourself that these components are sufficiently tempered before touching. Negligence of these precautions can lead to injuries.
8. The evaporator develops considerable cold during operation. Reassure yourself that the evaporator is sufficiently tempered before touching. Negligence of this precaution may lead to injuries.
9. The fan may cause injury during operation, avoiding touching the fans while the cabinet is connected to the mains. Negligence of these precautions can lead to injuries.
10. Make sure the ventilation system is properly installed to the cabinet's extraction ducts and are working as intended in order to prevent hazardous or dangerous situations.
11. No unauthorised modifications are allowed.

## Disposal

*This part describes the disposal of electrical and electronic equipment.*

At Gram BioLine we are dedicated to environmental sustainability and comply fully with the Waste Electrical and Electronic Equipment (WEEE) Directive.

Electrical and electronic equipment (EEE) contains materials, components and substances that can be dangerous and harmful to human health and the environment if the waste (WEEE) is not disposed of correctly. When disposing of the appliance in an EU Member State, it should be in accordance with the Waste Electrical and Electronic Equipment Regulations (WEEE).

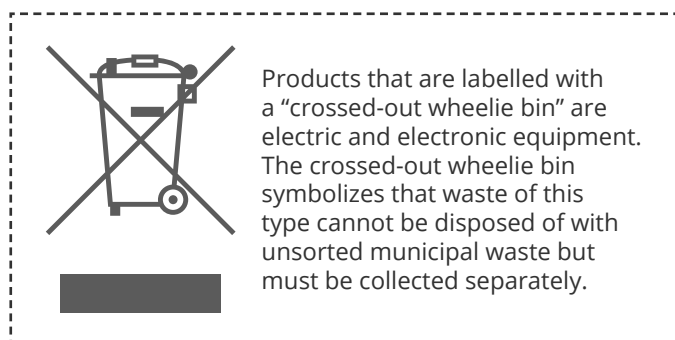

This refrigerator or freezer is specifically designed for bioscience purposes, it is therefore important to thoroughly clean the appliance to ensure that no residues or harmful substances remain. While it is not a requirement under the (WEEE) Directive to document the cleaning, it is considered good practice to ensure the refrigerator is free of contamination before it is sent for recycling or disposal. This helps protect individuals responsible for handling the appliance and ensures a safe and environmentally friendly recycling process.

Correct disposal and recycling of electrical and electronic equipment help reduce waste and minimize environmental impact. By adhering to proper handling practices, your organization supports pollution prevention and resource conservation. Recycled materials are sorted, cleaned, and processed for reuse, contributing to sustainability and reducing the need for new raw materials.

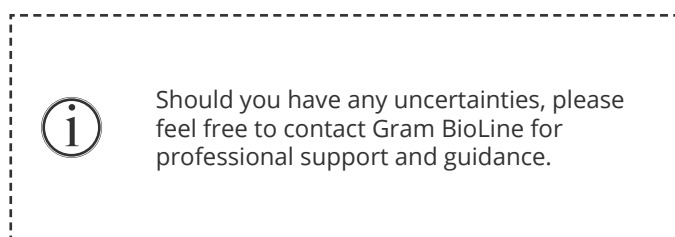

# Datasheet

## ExGuard ER600W

### General data: ExGuard ER600W

Technical specifications	Data
Ambient temperature range	Solid door +10/+43 °C Glass door +10/+38 °C
Temperature range	-2/+20 °C
Connection	230 VAC/50 Hz
Control Unit	2 x Gram BioLine MPC-46
SW variant (ER model)	M5+
SW variant (Extraction)	C1
Alarms	Acoustic and visual temperature and door alarms
Alarm ports	Voltage-free contact (230 VAC/8A)
Access port	1 pc. Ø24 mm
Gross volume	614 litres
Net volume	486 litres
Door	Right or left hinged, either solid or glass door
Material interior	Stainless steel
Materiale exterior	White lacquered steel or stainless steel
Wall thickness	70 mm
Door thickness – Solid door	80 mm
Insulation	Polyurethane foam
Dimensions: W x D x H	820 x 789 x 1996/2246 mm
Air system	Gram BioLine ventilated air distribution system
Defrost system	Automatic smart defrost with re-evaporation of the defrost water. Heating element
IP class	IP21
Ventilation connection	100 mm spiral ducting
Ventilation requirements	144 m <sup>3</sup> /h air flow per cabinet



## ExGuard ER600W G – Solid door

Technical specifications	Data
K-Value	0.2685 W/(m <sup>2</sup> *K)
ATEX certificate	ExVeritas 26ATEX2341X
ATEX Marking	II 3G Ex ec nC ic IIB T1 Gc
Refrigerant	R290
Refrigerant charge	90 g
Refrigeration capacity at -10 °C	389 W
GWP – CO <sub>2</sub> e	0.297
Energy consumption	1.793 kWh/24h
Heat emission 100 %	316.59 W
Heat emission default setpoint	77 W
Nominal consumption	316.3 W/1.9A
Start current	9.7A
Gross weight	157 kg
Net weight*	147 kg
Sound level	46,3 dB(A)

\* Unpackaged without interior fittings

## ExGuard ER600W G – Glass door

Technical specifications	Data
K-Value	0.453 W/(m <sup>2</sup> *K)
ATEX certificate	ExVeritas 26ATEX2341X
ATEX Marking	II 3G Ex ec nC ic IIB T1 Gc
Refrigerant	R290
Refrigerant charge	90 g
Refrigeration capacity at -10 °C	389 W
GWP – CO <sub>2</sub> e	0.297
Energy consumption	2,448 kWh/24h
Heat emission 100 %	319.25 W
Heat emission default setpoint	101 W
Nominal consumption	316.3 W/1.9A
Start current	9.7A
Gross weight	172 kg
Net weight*	162 kg
Sound level	45,3 dB(A)

\* Unpackaged without interior fittings

# Declaration of conformity



## English EC Declaration of Conformity

We, **Gram Scientific ApS**, declare as manufacturer under sole responsibility that the following products comply with all relevant regulations:

<b>Range:</b>	<b>ExGuard</b>
Model:	ER600W
Refrigeration:	R134a & R290
Product description:	Refrigerators for storing harmful or odorous chemicals with built in extraction system
Valid from (Year/Week):	2023/01

This declaration pertains to compliance with all applicable essential requirements and other provisions of the European Council Directive and regulations. Specifically, the following Directives and Regulations of the European Parliament and of the Council apply:

Directives and Regulations of the European Parliament and of the Council:
Machinery Directive 2006/42/EC - ATEX Directive 2014/34/EU - Pressure Equipment Directive 2014/68/EU - Low Voltage Directive 2014/35/EU - EMC Directive 2014/30/EU - RoHS Directive 2011/65/EU - REACH EC No.1907/2006 - F-Gas Regulation (EU) No 2024/573

Product compliance has been demonstrated based on the following harmonized standards:

Harmonized Standards:	Text:
EN 61010-1:2010	Safety requirements for electrical equipment for measurement, control, and laboratory use - Part 1: General requirements
EN 61326-1:2013	Electrical equipment for measurement, control and laboratory use – EMC requirements – Part 1: General requirements
EN IEC 60079-0:2018 EN IEC 60079-0:2018/AC:2020	Explosive atmospheres – Part 0: Equipment – General requirements
EN 60079-7:2015 EN 60079-7:2015/A1:2018	Explosive atmospheres – Part 7: Equipment protection by increased safety "e"
EN 60079-11:2012	Explosive atmospheres – Part 11: Equipment protection by intrinsic safety "i"
EN IEC 60079-15:2019	Explosive atmospheres – Part 15: Equipment protection by type of protection "n"
EN 60079-18:2015	Explosive atmospheres – Part 18: Equipment protection by encapsulation "m"
EN ISO 3744:2010	Acoustics – Determination of sound power levels and sound energy levels of noise sources using sound pressure – Engineering methods for an essentially free field over a reflecting plane
EN ISO 9001:2015	Quality management systems – Requirements
EN ISO 14001:2015	Environmental management systems – Requirements with guidance for use

Gram Scientific ApS  
Aage Grams Vej 1  
DK-6500 Vojens  
Denmark  
Telephone: + 45 73 20 13 00

Vojens, 21.03.2024

John B. S. Petersen  
Approval Manager

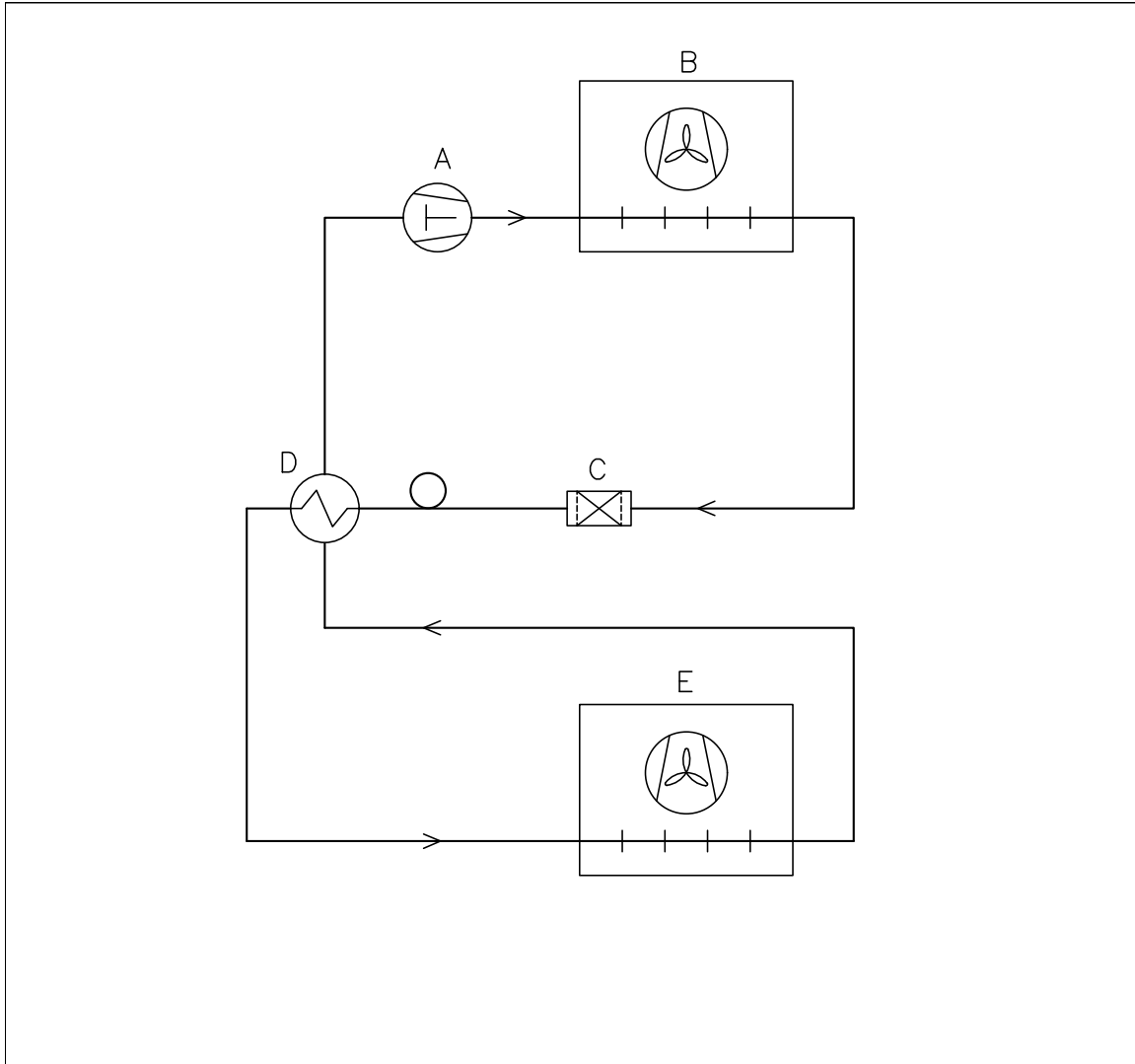

	DK	GB	D			
A	Kompressor	Compressor	Kompressor			
B	Kondensator	Condenser	Verflüssiger			
C	Tørrefilter	Filter drier	Trockenfilter			
D	Varmeudveksler	Heat exchanger	Wärmeaustauscher			
E	Fordamper	Evaporator	Verdampfer			
Revision			Inspection / important Dimension marked with			
Description.			<b>X.XX</b>			
Piping diagram ExGuard ER600W			General tolerance: ISO 2768-m : ISO 286-2			
Gram Scientific ApS (CVR-nr. 43122193) Aage Grams Vej 1 6500 Vojens	Date	Sign.	Sheetsize	Drawing no.	Sheet no.	Rev.
	09-01-2023	JABP	4			
All rights to this drawing belongs to Gram Scientific ApS, cf. law of Copyright. Thus the drawing should notwithout our written permission be copied, presented or passed over to a third person. Misuse will lead to prosecution.						

# Wiring diagram

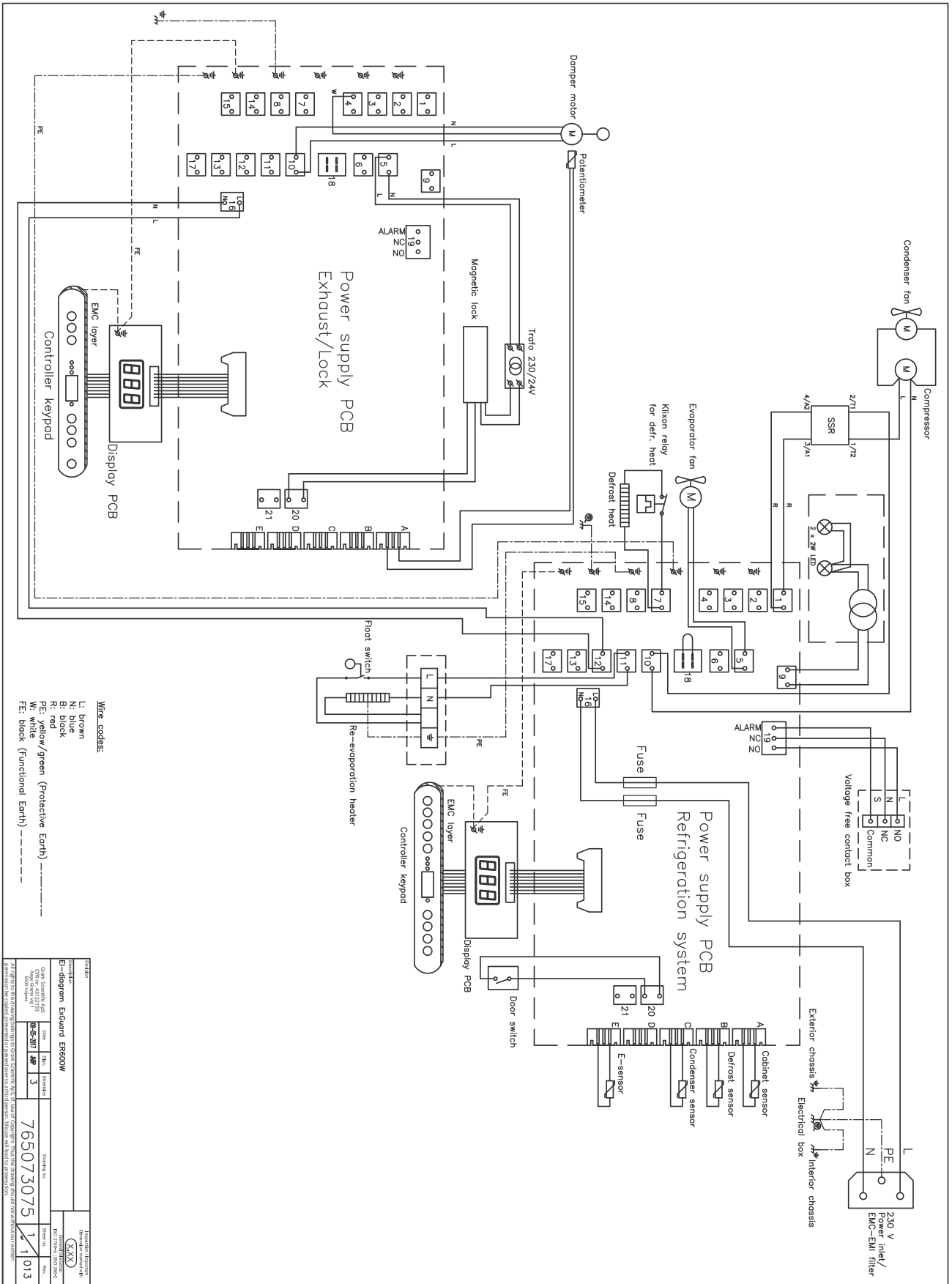



bioline

# General maintenance information

---

- Implement a cleaning routine.
- Cleaning tasks should be documented and kept record of.
- Check the temperature of your refrigerator/freezer regularly.
- When storing valuable or temperature-sensitive materials or products, it is advisable to employ a continuously monitoring autonomous alarm system. This alarm system should be designed in a manner that allows authorised individuals to promptly detect each alarm state and take the necessary corrective actions.

## **- WARNING -**

Maintenance work should only be performed by a Gram BioLine authorised technician.



Make sure that the refrigerator/freezer is switched off at the socket before any maintenance work is performed. Transfer all contents to another refrigerator or freezer under safe and regulated conditions.

## Maintenance plan

*The following maintenance plan represents a generic schedule for maintenance. Use and/or conditions may impact the required frequency of the subsequent points.*

Component	Task	Frequency
Base	<ul style="list-style-type: none"> <li>Ensure cabinets with legs are levelled properly and cabinets with castors are placed on a level surface and locked.</li> </ul>	Yearly
Interior fittings	<ul style="list-style-type: none"> <li>Ensure that all interior fittings are fixed correctly.</li> </ul>	Yearly
Door gasket	<ul style="list-style-type: none"> <li>Ensure that the gasket is pliable and in good working order.</li> <li>Ensure that the door is aligned with the door frame and fits tightly when closed.</li> </ul>	Yearly
Condenser and fan	<ul style="list-style-type: none"> <li>Ensure it is not dented or shows any other signs of damage and does not make any abnormal noises.</li> </ul>	Yearly
Keypad	<ul style="list-style-type: none"> <li>Ensure it is not dented or shows any other signs of damage.</li> </ul>	Yearly
Ice build-up	<ul style="list-style-type: none"> <li>Ensure ice accumulation does not hinder operation or performance.</li> </ul>	Monthly
Power cord	<ul style="list-style-type: none"> <li>Ensure correct fitment.</li> </ul>	Yearly
Compressor compartment	<ul style="list-style-type: none"> <li>Ensure that the compressor compartment is kept free of dust or other contaminants.</li> </ul>	Yearly
Re-evaporation tray	<ul style="list-style-type: none"> <li>Ensure it is not cracked or shows any other signs of damage.</li> </ul>	Yearly
Access port	<ul style="list-style-type: none"> <li>Ensure that the access port is sealed properly and check for moisture ingress.</li> </ul>	Yearly
Defrost water tube (if applicable)	<ul style="list-style-type: none"> <li>Inspect for damage and obstructions.</li> </ul>	Yearly
Door switch (if applicable)	<ul style="list-style-type: none"> <li>Ensure proper functionality to guarantee the fan in the cabinet stops, the interior lighting turns on if present, and the display shows "-0-".</li> </ul>	Yearly
Door alarm test	<ul style="list-style-type: none"> <li>Ensure it activates when the door is left open.</li> </ul>	Yearly
Temperature	<ul style="list-style-type: none"> <li>Ensure the appliance consistently maintains correct storage conditions.</li> <li>When storing valuable or temperature sensitive materials or products, it is advisable to employ a continuously monitoring autonomous alarm system. This alarm system should be designed in a manner that allows authorised individuals to promptly detect each alarm state and take the necessary corrective actions.</li> </ul>	Yearly

Component	Task	Frequency
High and low temperature alarms	<ul style="list-style-type: none"> <li>• Ensure that the temperature alarms are set and work accordingly.</li> <li>• When storing valuable or temperature sensitive materials or products, it is advisable to employ a continuously monitoring autonomous alarm system. This alarm system should be designed in a manner that allows authorised individuals to promptly detect each alarm state and take the necessary corrective actions.</li> </ul>	Yearly
Door hinges	<ul style="list-style-type: none"> <li>• Check for wear and ensure proper function.</li> </ul>	Yearly
Door self-closing mechanism	<ul style="list-style-type: none"> <li>• Ensure that the door automatically closes when opened &lt; 90 °.</li> <li>• Ensure that the door stays/do not close when opened &gt; 90 °.</li> </ul>	Yearly
Door handle (if applicable)	<ul style="list-style-type: none"> <li>• Ensure secure attachment and correct engagement.</li> </ul>	Yearly
Chart recorder (if applicable)	<ul style="list-style-type: none"> <li>• Ensure that it accurately records and stores temperature data.</li> </ul>	Yearly
Lock	<ul style="list-style-type: none"> <li>• Ensure it operates smoothly.</li> </ul>	Yearly
Sensors	<ul style="list-style-type: none"> <li>• Test sensors to ensure accurate readings and functionality.</li> </ul>	Yearly
Cleaning	<ul style="list-style-type: none"> <li>• Refer to the cleaning section.</li> </ul>	

**– SPARE PARTS –**



If you require spare parts, please contact your local Gram BioLine distributor. Defective parts must be replaced with original parts from Gram BioLine. Gram BioLine can only guarantee functional and safety requirements on the cabinets, if above mentioned is adhered to.

- The refrigerator/freezer must be cleaned before taken into operation.
- We recommend cleaning the refrigerator/freezer regularly to ensure efficient operation.
- We recommend using pH-neutral all-purpose cleaners and soft cleaning cloths.
- If any detergent or cleaning agent are used to clean the refrigerator/freezer, ensure that the refrigerator/freezer is thoroughly rinsed with clean water and a clean cloth to remove any cleaning agent or detergent traces.
- Ensure that the refrigerator/freezer has been dried thoroughly with a clean cloth before taken into operation.

**- WARNING -**

**Do not use the below disinfectants and cleaners:**



- Do not use abrasive cleaners.
- Do not use harsh chemicals.
- Do not use solvents.
- Do not use acidic or alkaline cleaners nor any cleaning agents that contain chloride.

**- WARNING -**

**Do not use the below tools in general:**



- Do not use metal brushes.
- Do not use water jets.
- Do not use abrasive sponges or steel wool.
- Do not use any sharp tools.
- Do not use electrical heating or steam-cleaning appliances, flames, or defroster sprays to defrost.

**- WARNING -**

- Do not remove the type/number plate, located inside the refrigerator/freezer (refer to type/number plate section).
- Make sure no water gets close to any electrical components.
- Do not flush the compressor compartment and evaporator with water as this may cause short-circuits in the electrical system.



# Cleaning plan

The following cleaning plan represents a generic schedule for cleaning. Use and/or conditions may impact the required frequency of the subsequent points.

Task	Minimum maintenance interval
Cleaning the air filters (if applicable)	Yearly
Cleaning the re-evaporation tray	Yearly
Cleaning the exterior	Half-yearly
Cleaning the interior	Half-yearly
Cleaning the shelves/drawers	Regularly
Cleaning the condenser and the compressor compartment	Yearly
Cleaning the door gasket	Regularly
Cleaning the defrost water tube (if applicable)	Yearly

## Cleaning the air filters (if applicable)



**- WARNING -**

- The air filters should only be re-attached when completely dry.

### Cleaning agents and tools

- pH-neutral all-purpose cleaners (optional).
- Soft cloth (optional).
- Bucket or similar (optional).

The air filters on the condenser and the front panel should be removed and cleaned with lukewarm water (max. 50° C). If the air filters are very dirty fill a bucket or similar with a mild solution of pH-neutral all-purpose cleaner. Submerge the air filters completely for approximately 10 minutes and rinse thoroughly with clean warm water. Let the air filter air-dry completely before reattaching them.

## Cleaning the re-evaporation tray



**- WARNING -**

- Be careful not to damage the defrost water tube and the heating element (located in the tray) when cleaning.

### Cleaning agents and tools

- Soft cloth.
- pH-neutral all-purpose cleaner.

It is recommended that the re-evaporation tray is checked regularly for foreign objects and cleaned with a pH-neutral all-purpose cleaner at least once a year. Rinse the tray thoroughly with clean warm water and remember to dry the re-evaporation tray completely.

## Cleaning the interior and exterior



**- WARNING -**

- Do not use any tools or methods to speed up defrosting other than the ones specified in this instructions for use.
- Do not pour water directly into the unit.

### Cleaning agents and tools

- pH-neutral all-purpose cleaners.
- Use a soft cloth to clean off dust or other contaminants from the refrigerator or freezer.

### Manual defrost

Our conventional refrigerators/freezers feature automatic defrosts (see section for defrost) but the refrigerator/freezer should be manually defrosted prior to cleaning. Make sure all contents are stored elsewhere before defrosting.

Manual defrosting is done by switching off the refrigerator/freezer at the socket. Leave the door open for 24 hours and be cautious of excess water being spilled onto the floor. Be sure to keep the floor and the interior as dry as possible during the process by placing towels or similar onto the surfaces.

Remove all shelves and drawers and clean the cabinet (max. 85° C). Rinse the refrigerator/freezer thoroughly with clean warm water. Check and dry thoroughly before it is put into operation again.

---

## Cleaning the shelves/drawers



**- WARNING -**

- Shelves/drawers shall be hand washed.
- Do not use excessive force when removing and inserting the shelves/drawers.

### Cleaning agents and tools

- pH-neutral all-purpose cleaners.
- Soft cloth.

Remove all shelves/drawers from the refrigerator/freezer and wash them using a soft cloth. Rinse the shelves/drawers thoroughly with clean warm water. Check and dry thoroughly before it is put into operation again.

## Cleaning the condenser and the compressor compartment



**- WARNING -**

- Ensure not to damage the condenser.
- Components in the compressor compartment may be hot.
- The refrigeration system and the hermetically sealed compressor require no maintenance.

### Tools

- Use a brush, a soft cloth, or a vacuum cleaner.

The compressor compartment and in particular the condenser must be kept free from dust or other contaminants.

## Cleaning the door gasket



**- WARNING -**

- Do not pour water directly into the unit.

### Cleaning agents and tools

- pH-neutral all-purpose cleaners.
- Use a brush, a soft cloth, or a vacuum cleaner.

The door gasket should be cleaned regularly using a soft cloth. Dry the gasket completely with a clean cloth before taking the refrigerator/freezer into operation.

## Cleaning the defrost water tube (if applicable)



**- WARNING -**

- Do not pour water directly into the unit.

### Cleaning agents and tools

- pH-neutral all-purpose cleaners.
- Use a brush, a soft cloth, or a vacuum cleaner.

Remove the elastic water trap, located on the back of the cabinet, as illustrated. Inspect the defrost water tube for obstructions. Rinse and clean it and reinstall.

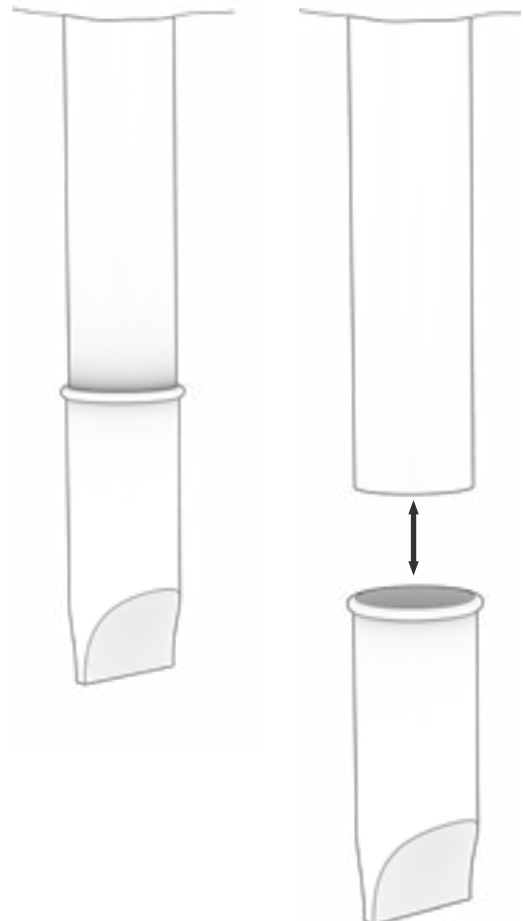

# FAQ

Complication	Cause	Approach
Temperature fluctuations	Frequent door openings	<ul style="list-style-type: none"> <li>• Make the door openings as brief as possible.</li> </ul>
	Malfunctioning temperature sensor	<ul style="list-style-type: none"> <li>• Use an independent temperature measurement device to measure the temperature inside the refrigerator/freezer to evaluate if it differs from the readings of the sensors in the appliance.</li> <li>• In case of significant temperature difference – contact Gram BioLine technical support.</li> </ul>
	Dirty condenser	<ul style="list-style-type: none"> <li>• Clean the condenser.</li> </ul>
	Item distribution	<ul style="list-style-type: none"> <li>• Ensure that the contents are evenly distributed and do not obstruct air circulation.</li> </ul>
	Ambient conditions	<ul style="list-style-type: none"> <li>• Ensure that the ambient temperature does not exceed the specified limits in this instructions for use.</li> <li>• Ensure the cabinet is not in direct contact with sunlight or effected by other heat sources.</li> <li>• The user must ensure that the cabinet is used in accordance with its intended use and that the humidity does not exceed 70%.</li> <li>• Ensure adequate ventilation around the refrigerator/freezer. (Refer to surroundings section)</li> </ul>
	Item temperature	<ul style="list-style-type: none"> <li>• Ensure that all contents are at set temperature before they are placed inside the refrigerator/freezer.</li> </ul>
The refrigerator/freezer is not working	Power supply	<ul style="list-style-type: none"> <li>• Ensure that the power cord is securely plugged into the socket and the refrigerator/freezer.</li> </ul>
	Power outage	<ul style="list-style-type: none"> <li>• Keep the door closed.</li> <li>• Use a backup power source if available.</li> <li>• Move contents to a working unit if available.</li> </ul>
	Faulty outlet	<ul style="list-style-type: none"> <li>• Check for blown fuses.</li> <li>• Check the circuit breaker and RCD (Residual Current Device).</li> </ul>

**- INFORMATION -**

 If any issues persist, do not hesitate to reach out to Gram BioLine for professional support, at [support@gram-bioline.com](mailto:support@gram-bioline.com).

Complication	Cause	Approach
Noisy	Unlevel refrigerator/freezer	<ul style="list-style-type: none"> <li>• Ensure that the floor is level.</li> <li>• Ensure that the base of the refrigerator/freezer is level. (Refer to installation section).</li> </ul>
	Direct contact with other objects	<ul style="list-style-type: none"> <li>• Ensure that the refrigerator/freezer is not in contact with the wall.</li> <li>• Ensure that the refrigerator/freezer is not in contact with another appliance or other objects.</li> </ul>
	Fans (if applicable)	<ul style="list-style-type: none"> <li>• Ensure the fans are operational and does not make any abnormal sounds.</li> </ul>
Refrigerator/freezer unable to reach set temperature	Discrepancy between E-sensor and set temperature	<ul style="list-style-type: none"> <li>• The display may show a different temperature because the E-sensor is located at the warmest spot in the unit.</li> </ul> <p>However, the temperature in the central area where contents are stored should be at the set temperature.</p> <p>Verify this with an independent temperature measurement. If you have concerns, please contact our customer support team.</p>
	Damaged door gasket	<ul style="list-style-type: none"> <li>• Ensure that the gasket is pliable and in good working order.</li> </ul>
Need for spare parts	Replacement parts are required	<ul style="list-style-type: none"> <li>• If you require spare parts, please contact your local Gram BioLine distributor.</li> </ul>

**- INFORMATION -**

 If any issues persist, do not hesitate to reach out to Gram BioLine for professional support, at [support@gram-bioline.com](mailto:support@gram-bioline.com).

## Installation & Operation Qualification

The following IQ/OQ is intended to be a guideline, local IQ/OQ procedures can vary depending on application and items stored in the Gram BioLine cabinet.

Deviations from the specifications dictated in the PQ are to be reported in the deviation report.

The PQ is concluded if all criteria of acceptance are approved and the possible deviations are rectified or accepted.

Organisation:

---

---

---

Location of installation:

---

---

---

Model:

---

Serial number:

---

Item and revision number of instructions for use:

---

Status of operation:

- Active  
 Inactive

Name of vendor:

---

---

---

Warranty:

Start: \_\_\_\_\_

End: \_\_\_\_\_

Model: \_\_\_\_\_

SN: \_\_\_\_\_

Instructions on use to starting the cabinet:

- 1. Training of the responsible party    Date: \_\_\_\_\_    By: \_\_\_\_\_
- 2. Operational test of the cabinet    Date: \_\_\_\_\_    By: \_\_\_\_\_
- 3. Responsible party    \_\_\_\_\_    Tel: \_\_\_\_\_

Instructions to users:

*The responsible party is trained in use of the cabinet in reference to the user manual*

- General use of the cabinet
- Service & maintenance
- The cabinet was delivered without defects/damage.  
The cabinet started as specified in the user manual

Objections to the mentioned:

\_\_\_\_\_

\_\_\_\_\_

\_\_\_\_\_

\_\_\_\_\_

**Set values:**

- Setpoint temperature \_\_\_\_\_ °C

**Local alarm settings**

- High temperature alarm (LhL) \_\_\_\_\_ °C
- Low temperature alarm (LLL) \_\_\_\_\_ °C

**External alarm settings**

(See voltage free contact in user manual)

- High temperature alarm EhL) \_\_\_\_\_ °C
- Low temperature alarm (ELL) \_\_\_\_\_ °C

**Factory settings:**

Model/Setpoint temperature	LhL	LLL	EhL	ELL
ER600W	+5 °C	+25 °C	-5 °C	+25 °C
				-5 °C

Date: \_\_\_\_\_    Name of trained user: \_\_\_\_\_    Signature: \_\_\_\_\_    Name of instructor: \_\_\_\_\_    Signature: \_\_\_\_\_

\_\_\_\_\_

\_\_\_\_\_

\_\_\_\_\_

\_\_\_\_\_

Model: \_\_\_\_\_    SN: \_\_\_\_\_

## Installation Qualification – IQ

ID	Description of installation	Reference in manual	Comply		Attachment	Notes
			YES	NO		
I-0	The cabinet is shipped with a transport bracket that should be removed prior to use.	N/A				
I-1	Ensure the cabinet is installed indoors.	page 8				
I-2	Ensure the cabinet is installed in a dry and sufficiently ventilated area.	page 8				
I-3	Ensure the cabinet is not in direct contact with sunlight or other heat sources.	page 8				
I-4	Ensure that the ambient operating temperature is within the allowed range.	page 8				
I-5	Ensure that the cabinet is not installed in a chloric/acidic environment.	page 8				
I-6	Ensure that the protective film on the cabinet is removed.	page 8				
I-7	Ensure that the cabinet is cleaned with a mild soap solution.	page 9				
I-8	Ensure that the cabinet has stood upright for 24 hours if the cabinet has been laying down.	page 9				
I-9	Ensure that the cabinet is levelled if it is equipped with legs.	page 9				
I-10	Ensure a level surface if the cabinet is equipped with wheels/castors.	page 9				
I-11	If equipped with wheels/castors: Ensure wheels/castors are locked after positioning.	page 9				
I-12	If equipped with drawers and/or a glass door: Ensure that anti tilt-bracket is mounted.	page 10				
I-13	Ensure a distance of 15-75 mm between the cabinet and the back wall.	page 11				
I-14	Ensure that there is a minimum gap of 30 mm between cabinets.	page 11				
I-15	Ensure that the upper part of the cabinet is not covered.	page 11				
I-16	Ensure that electrical appliances are not being used inside the cabinet.	page 11				
I-17	Ensure connection from the voltage-free contact to the external monitoring system (optional)	page 13				

## Installation Qualification – IQ

ID	Description of installation	Reference in manual	Comply		Attachment	Notes
			YES	NO		
I-18	Ensure that the inner doors can operate in accordance with the instructions.	N/A				
I-19	Ensure the correct electrical connection (compare local values with type/no. plate)	page 14				
I-20-1	Ensure that the power cord is secured by the preload cover.	N/A				
I-20-2	Ensure that the power cord is secured by the hanger.	page 14				
I-21	Mark power cord with: "Do not separate when energized".	page 14				
I-22-1	Ensure equipotential bonding (applicable for ATEX Cat.3 Zone 2 areas).	page 16				

Model: \_\_\_\_\_

SN: \_\_\_\_\_

## Operation Qualification – OQ

ID	Description of installation	Reference in manual	Comply		Attachment	Notes
			YES	NO		
O-1	Turn on the cabinet – Display test (software version and variant).	page 18				
O-2	Set/adjust set-point temperature.	page 18				
O-3	Set/adjust LhL – Upper alarm limit (local).	page 22				
O-4	Set/adjust LLL – Lower alarm limit (local).	page 22				
O-5	Set/adjust Lhd – Delay of the upper alarm limit (local).	page 23				
O-6	Set/adjust LLd – Delay of the lower alarm limit (local).	page 23				
O-7	Activate/deactivate dA – Door alarm (local).	page 24				
O-8	Set/adjust dAd – Delay of the door alarm (local).	page 24				
O-9	Activate/deactivate BU – Acoustic alarms (local).	page 25				
O-10	Set/adjust EhL – Upper alarm limit (external).	page 26				
O-11	Set/adjust ELL – Lower alarm limit (external).	page 26				
O-12	Set/adjust Ehd – Delay of the upper alarm limit (external).	page 27				
O-13	Set/adjust ELd – Delay of the lower alarm limit (external).	page 27				
O-14	Activate/deactivate dA – Door alarm (external)	page 28				
O-15	Set/adjust dAd – Delay of the door alarm (external).	page 29				
O-16	Activate/deactivate BU – Acoustic external alarms.	page 30				
O-17	Set/adjust defrost cycles (deF) per 24 hours (factory setting: 4).	page 34				
O-18	Select reference sensor for the display (dps) (A or E).	page 35				

Model: \_\_\_\_\_

SN: \_\_\_\_\_

## Deviation Report

Deviations to the criteria of acceptance are to be documented in the deviation report. A separate deviation report shall be made for each deviation. Mark the entry with the relevant “-ID” specified in the left column in the test specifications.

-ID: \_\_\_\_\_

Description of the deviation:

---

---

---

---

---

Extent to which the deviation has been alleviated:

---

---

---

---

---

Additional notes:

---

---

---

---

---

Person responsible for the test:

Name: \_\_\_\_\_

Date: \_\_\_\_\_

Organisation: \_\_\_\_\_

Signature: \_\_\_\_\_

Person responsible for verification of the test:

Name: \_\_\_\_\_

Date: \_\_\_\_\_

Organisation: \_\_\_\_\_

Signature: \_\_\_\_\_

Model: \_\_\_\_\_

SN: \_\_\_\_\_

---

Approval of the test results – Installation Qualification (IQ)

- The steps in the Installation Qualification – IQ were completed with positive results
- The steps in the Installation Qualification – IQ were completed with negative results

ID of steps with negative results: \_\_\_\_\_

Approval of the test results – Operation Qualification (OQ)

- The steps in the Operation Qualification – OQ were completed with positive results
- The steps in the Operation Qualification – OQ were completed with negative results

ID of steps with negative results: \_\_\_\_\_

Organisation/Responsible party: \_\_\_\_\_

Trainer/Responsible party: \_\_\_\_\_

\_\_\_\_\_  
Stamp & Signature

\_\_\_\_\_  
Stamp & Signature

\_\_\_\_\_  
Tel.

\_\_\_\_\_  
Tel.

\_\_\_\_\_  
e-mail

\_\_\_\_\_  
e-mail

\_\_\_\_\_  
Location & Date

\_\_\_\_\_  
Location & Date

Model: \_\_\_\_\_

SN: \_\_\_\_\_



## Performance Qualification

Organisation:

\_\_\_\_\_  
\_\_\_\_\_  
\_\_\_\_\_

Location of the installation:

\_\_\_\_\_  
\_\_\_\_\_  
\_\_\_\_\_

Model: \_\_\_\_\_ SN: \_\_\_\_\_ Item number: \_\_\_\_\_  
(manual)

The PQ consists of inspections of the correct operation of the cabinet under predefined conditions and procedures. Prerequisites for the PQ are IQ (Installation Qualification) and OQ (Operation Qualification), these must be concluded successfully prior to the initiation of the PQ.

Person responsible for the cabinet:

Name: \_\_\_\_\_  
Date: \_\_\_\_\_  
Signature: \_\_\_\_\_

Person responsible for the test:

Name: \_\_\_\_\_  
Date: \_\_\_\_\_  
Organisation: \_\_\_\_\_  
Signature: \_\_\_\_\_

Person responsible for the verification of the test:

Name: \_\_\_\_\_  
Date: \_\_\_\_\_  
Organisation: \_\_\_\_\_  
Signature: \_\_\_\_\_

Test duration:

Initiation (date/time): \_\_\_\_\_  
Conclusion (date/time): \_\_\_\_\_  
Date: \_\_\_\_\_  
Organisation: \_\_\_\_\_  
Signature: \_\_\_\_\_

Model: \_\_\_\_\_ SN: \_\_\_\_\_



Deviations from the specifications dictated in the PQ, are to be reported in the deviation report.  
 The PQ is concluded if all criteria of acceptance are approved and the possible deviations are rectified or accepted.

## Measurements – Prerequisites

ID	Description	Accepted	
		Yes	No
P-1	The cabinet must be empty while conducting tests, ie without interior fittings such as drawers, shelves etc.  Attachment:  Notes:		
P-2	The measurements must be conducted in accordance to IEC 60068-3-5.  Attachment:  Notes:		
P-3	The positioning of the sensors in the cabinet must be documented with a sketch and/or a photograph.  Attachment:  Notes:		

Name:

Signature:

Approved  
(Yes/No):

Date:

Conducted by:

\_\_\_\_\_

\_\_\_\_\_

\_\_\_\_\_

\_\_\_\_\_

Inspected/verified by:

\_\_\_\_\_

\_\_\_\_\_

\_\_\_\_\_

\_\_\_\_\_

Model: \_\_\_\_\_

SN: \_\_\_\_\_

Deviations from the specifications dictated in the PQ, are to be reported in the deviation report.  
 The PQ is concluded if all criteria of acceptance are approved and the possible deviations are rectified or accepted.

### Measurements – Prerequisites

ID	Description	Accepted	
		Yes	No
P-4	Measurements made during the PQ tests must be documented and attached to the PQ.  Attachment:  Notes:		
P-5	Specify setpoint temperature: _____°C  Specify the ambient temperature: _____°C  Attachment:  Notes:		
P-6	Allowed tolerances – Select the tolerance, according to the model being tested. Find model-specific tolerances in appendix.  Tolerance: +/- _____ K  Attachment:  Notes:		

Name: \_\_\_\_\_ Signature: \_\_\_\_\_ Approved (Yes/No): \_\_\_\_\_ Date: \_\_\_\_\_  
 Conducted by: \_\_\_\_\_  
 Inspected/verified by: \_\_\_\_\_  
 Model: \_\_\_\_\_ SN: \_\_\_\_\_

Deviations from the specifications dictated in the PQ, are to be reported in the deviation report.  
 The PQ is concluded if all criteria of acceptance are approved and the possible deviations are rectified or accepted.

## Measurements – Temperature stabilisation

ID	Description	Accepted	
		Yes	No
P-7	<p>The test is intended to provide substantiation for the temperature stability inside the cabinet during normal operation.</p> <p>The temperature inside the cabinet must be stabilised – Where all the points in the working space have reached and maintained the same temperature.</p> <p>When the system is stable, document ordinary operation of the cabinet at the setpoint temperature and ambient temperature specified in P-5.</p> <p>Duration: _____</p> <p>The measurements throughout the operation test, must be documented and attached the PQ.</p> <p>Attachment:</p> <p>Notes:</p>		
P-8	<p>Are the measurements inside the allowed tolerances specified in P-6 ?</p> <p>Attachment:</p> <p>Notes:</p>		

Name: \_\_\_\_\_ Signature: \_\_\_\_\_ Approved (Yes/No): \_\_\_\_\_ Date: \_\_\_\_\_

Conducted by: \_\_\_\_\_

Inspected/verified by: \_\_\_\_\_

Model: \_\_\_\_\_ SN: \_\_\_\_\_

Deviations from the specifications dictated in the PQ, are to be reported in the deviation report.  
 The PQ is concluded if all criteria of acceptance are approved and the possible deviations are rectified or accepted.

## Measurements – Door opening test

ID	Description	Accepted	
		Yes	No
P-9	<p>The test is intended to provide substantiation for the temperature recovery time inside the cabinet subsequently after a door opening.</p> <p>The temperature inside the cabinet must be stabilised – Where all the points in the working space have reached and maintained the same temperature, the setpoint temperature is specified in P-5.</p> <p>When the system is stable, open the door at 90° for 60 seconds.</p> <p>The measurements, throughout the door opening test, must be documented and attached the PQ.</p> <p>Duration: _____</p> <p>Attachment:</p> <p>Notes:</p>		
P-10	<p>Has the setpoint temperature specified in P-5, measured in the absolute centre of the cabinet, been achieved within the set time-frame specified in the appendix?</p> <p>Attachment:</p> <p>Notes:</p>		

Name: \_\_\_\_\_ Signature: \_\_\_\_\_ Approved (Yes/No): \_\_\_\_\_ Date: \_\_\_\_\_  
 Conducted by: \_\_\_\_\_  
 Inspected/verified by: \_\_\_\_\_  
 Model: \_\_\_\_\_ SN: \_\_\_\_\_

Deviations from the specifications dictated in the PQ, are to be reported in the deviation report.  
 The PQ is concluded if all criteria of acceptance are approved and the possible deviations are rectified or accepted.

## Measurements – Pull-down

ID	Description	Accepted	
		Yes	No
P-11	<p>The test is intended to provide substantiation for the time it takes for the inside of the cabinet to reach the setpoint temperature specified in P-5.            The initial temperature in the working space is the ambient temperature specified in P-5.            The temperature inside the cabinet must be stabilised in all points of the working space.</p> <p>When the system is stable. Turn on the power to the cabinet.</p> <p>The measurements, throughout the pull-down test, must be documented and attached the PQ.</p> <p>Duration: _____</p> <p>Attachment:</p> <p>Notes:</p>		
P-12	<p>The time it takes the inside of the cabinet to achieve the setpoint temperature measured in the absolute centre, must not exceed the time-frame specified in the appendix.</p> <p>Have the criteria been met?</p> <p>Attachment:</p> <p>Notes:</p>		

Name: \_\_\_\_\_ Signature: \_\_\_\_\_ Approved (Yes/No): \_\_\_\_\_ Date: \_\_\_\_\_

Conducted by: \_\_\_\_\_

Inspected/verified by: \_\_\_\_\_

Model: \_\_\_\_\_ SN: \_\_\_\_\_

Deviations from the specifications dictated in the PQ, are to be reported in the deviation report.  
 The PQ is concluded if all criteria of acceptance are approved and the possible deviations are rectified or accepted.

## Measurements – Hold-over

ID	Description	Accepted	
		Yes	No
P-13	<p>The test is intended to provide substantiation for the time it takes for the temperature inside the cabinet to reach the end temperature specified in the appendix.            Ambient temperature and setpoint temperature is specified in P-5.</p> <p>The temperature inside the cabinet must be stabilised – Where all the points in the working space have reached and maintained the same temperature throughout, the tolerances are specified in P-6.</p> <p>When the system is stable, turn off the power to the cabinet.</p> <p>The measurements, throughout the hold-over test, must be documented and attached the PQ.</p> <p>Attachment:</p> <p>Notes:</p>		
P-14	<p>The times it takes the inside of the cabinet to reach the end temperature, must at least be the time specified in the appendix.</p> <p>Duration: _____</p> <p>Have the criteria been met?</p> <p>Attachment:</p> <p>Notes:</p>		

Name: \_\_\_\_\_ Signature: \_\_\_\_\_ Approved (Yes/No): \_\_\_\_\_ Date: \_\_\_\_\_  
 Conducted by: \_\_\_\_\_  
 Inspected/verified by: \_\_\_\_\_  
 Model: \_\_\_\_\_ SN: \_\_\_\_\_

---

## Deviation Report

Deviations to the criteria of acceptance are to be documented in the deviation report. A separate deviation report shall be made for each deviation. Mark the entry with the relevant "P-ID" specified in the left column in the test specifications.

P-ID: \_\_\_\_\_

**Description of deviation:**

---

---

---

---

---

**Extent to which the deviation has been alleviated:**

---

---

---

---

---

**Additional notes:**

---

---

---

---

---

Person responsible for the test:

Name: \_\_\_\_\_

Date: \_\_\_\_\_

Organisation: \_\_\_\_\_

Signature: \_\_\_\_\_

Person responsible for verification of the test:

Name: \_\_\_\_\_

Date: \_\_\_\_\_

Organisation: \_\_\_\_\_

Signature: \_\_\_\_\_

Model: \_\_\_\_\_

SN: \_\_\_\_\_

Approval of the test results – Performance Qualification (PQ)

- The steps in the Performance Qualification – PQ were completed with positive results
- The steps in the Performance Qualification – PQ were completed with negative results

ID of steps with negative results: \_\_\_\_\_

**Additional notes:**

---

---

---

---

---

Organisation/Responsible party: \_\_\_\_\_

Trainer/Responsible party: \_\_\_\_\_

Stamp & Signature \_\_\_\_\_

Stamp & Signature \_\_\_\_\_

Tel. \_\_\_\_\_

Tel. \_\_\_\_\_

e-mail \_\_\_\_\_

email \_\_\_\_\_

Location & Date \_\_\_\_\_

Location & Date \_\_\_\_\_

Model: \_\_\_\_\_

SN: \_\_\_\_\_



Appendix:

Model	Tolerances	Door opening - recovery time	Pull-down	Hold-over range*	Hold-over
ExGuard ER600W					

\* The temperature span between the initial temperature and the end temperature in the hold-over test P-13,14.

Conducted by:      Name: \_\_\_\_\_      Signature: \_\_\_\_\_      Approved (Yes/No): \_\_\_\_\_      Date: \_\_\_\_\_

Inspected/verified by: \_\_\_\_\_

Model: \_\_\_\_\_      SN: \_\_\_\_\_

# Index

---

<b>A</b>	
Access port	55
Alarm settings, external	26
Alarm settings, local	22
Ambient temperature	8
Anti-tilt bracket	10
<b>B</b>	
Buzzer	46
<b>C</b>	
Cabinet components	6
Cleaning	48, 67, 68
Connection to power	14
Connection to the ventilation system	12
<b>D</b>	
Damper open time	40
Datasheet	58
Declaration of conformity	60
Defrost	34, 52
Digital display	18, 36
Display sensor	35
Disposal	57
Door alarm	42, 43
Door gasket	49
Door lock	42, 54
Door self-closing mechanism	53
Dry cool	21
<b>E</b>	
Equipotential bonding	16
Error codes	20
Escorted/set alarm limits	33
External alarm settings	26
Extraction alarm	44
Extraction controller	17
Extraction extra time	45
<b>F</b>	
FAQ	72
Feedback sensor	41
<b>G</b>	
General info	50
General maintenance information	64
<b>I</b>	
Important	56
Initial setup	8
Installation	8
IQ, OQ, PQ	74, 82
<b>L</b>	
Local alarm settings	22
<b>M</b>	
Maintenance	48, 64, 65
Menu	19, 37
<b>O</b>	
Opening and closing the door	39
Operation controller	17
Ordinary use	47
<b>P</b>	
Parameter settings	31, 40
Periodic extraction frequency	45
Piping diagram	61
<b>Q</b>	
Quick Guide	2
<b>R</b>	
Responsibility	50
<b>S</b>	
Safety	5
Self-closing mechanism	53
Sensor offset	31, 32
Start-up	18, 36
Surroundings	11
Symbols	5
<b>T</b>	
Table of content	4
Type/number plate	51
<b>V</b>	
Ventilation system	12
Voltage-free contact	13
<b>W</b>	
Wiring diagram	62



**Gram Scientific ApS**

Aage Grams Vej 1 · 6500 Vojens · Denmark

Tel: +45 73 20 13 00

e-mail: [info@gram-bioline.com](mailto:info@gram-bioline.com)

[www.gram-bioline.com](http://www.gram-bioline.com)



Biostorage you can depend on