

BioUltra

INSTRUCTIONS FOR USE

MODEL: UL570

Original Instructions for use

Item No. 765041576
Revision No. 20260430
Language English

GRAM
Biostorage you can depend on

Quick Guide – BioUltra

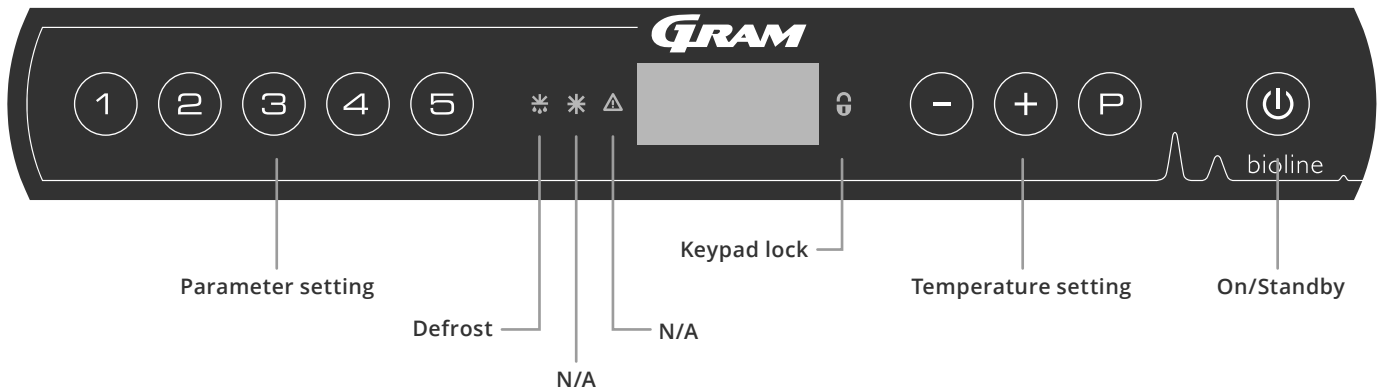

On/Standby

Press the key to turn the cabinet on. Press the key for 6 seconds to switch to standby. The software version of the cabinet will be shown when turning the cabinet on, followed by the variant. The cabinet is ready when the temperature is displayed.

Setting the temperature

Temperature adjustments are done by holding the key and pressing either or . Confirm the settings by letting go of the keys.

User menu

Menu Access + →	↓	→		
Local alarm settings	LAL	LhL	[° C]	Upper alarm limit. Code for activated alarm [A2]
		LLL	[° C]	Lower alarm limit. Code for activated alarm [A3]
		Lhd	[min.]	Delay of upper alarm limit
		LLd	[min.]	Delay of lower alarm limit
		BU	On/off	Acoustic signal for alarm codes [A2] and [A3]. [1=on/0=off]
External alarm settings	EAL	EhL	[° C]	Upper alarm limit. Code for activated alarm [A4]
		ELL	[° C]	Lower alarm limit. Code for activated alarm [A5]
		Ehd	[min.]	Delay of upper alarm limit
		ELd	[min.]	Delay of lower alarm limit
		BU	On/off	Acoustic signal for external alarm codes [A4], [A5]. [1=on/0=off]
Offset of sensors	cAL	cA	[K]	Offset of A-sensor. Reference sensor for the refrigeration system
		cE	[K]	Offset of E-sensor. Reference sensor for the display and alarms
	ALL			Activation of escorted alarm limits. [FAS] locked limits/[ESC]=follows setpoint
	dPS			Reference sensor for the display (A or E) (E is factory setting)

Example: Setting the upper limits for the alarms; LhL

- ↳ Press and hold + for more than 3 seconds until the display shows LAL
- ↳ Press to select LAL, LhL is now shown in the display
- ↳ Press to select LhL, 25 is shown in the display
- ↳ Press or to set the desired value for the upper temperature limit
- ↳ Press to confirm the set value
- ↳ Press two times to return to LAL
- ↳ Press to reach the next level, EAL, cAL, ALL and dPS are located on the same level
- ↳ Press to leave the user menu

Alarms

Alarm codes	[A2]	The upper alarm limits, (LhL) alarm is or has been activated
	[A3]	The lower alarm limits, (LLL) alarm is or has been activated

Acknowledging an acoustic alarm

Temperature alarm codes [A2] and/or [A3]: Flashes in the display. Press P to acknowledge. The display will continue to flash if the temperature is outside the alarm limits.

Latching alarms: [A2], [A3], [A4], [A5]

Due to the potential implications of alarms, the red alarm triangle icon will turn on along with the corresponding alarm code will flash in the display. The alarm state will remain on until acknowledged by pressing P .

Read-out of the max./min. temperature

Read the highest recorded temperature inside the cabinet by holding down + . Read the lowest recorded temperature inside the cabinet by holding down - .

Reading the alarm history - Example [A2]

[A2] Flashes in the display – This means that the temperature has exceeded the set value for the upper temperature limit, LhL. Press P to acknowledge the [A2]. The display continues to flash, indicating that there is information in the alarm history. Press + , Htt (High temperature time) is shown. Press P to see for how long the temperature was above the set alarm limit. Press P to return to Htt. Press + to reach Ht (Highest temperature). Press P to read the highest recorded temperature during Htt. Press P to return to Ht and press P again to leave the alarm history function. The procedure for reading an [A3] alarm is identical, apart from entering the alarm history with the - key. When reading out temperatures below set limits, the parameters are Ltt and Lt. A flashing display with no alarm codes indicates that the alarm codes have been acknowledged, but the alarm system contains information.

Resetting the alarm temperature and the alarm history

Resetting of the max./min. and alarm history is done by holding - and + for more than three seconds. An acoustic signal will be given when reset is complete.

Sensor read-out and error codes

Menu Access $\text{P} + \text{E} \rightarrow$	\downarrow	$\text{P} \rightarrow$ [° C]	Display code and its message	
Sensor for refrigeration system	P-A	Value on sensor for refrigeration system	F1	Error on the sensor for refrigeration system
Sensor for evaporator	P-B	Value for evaporator sensor	F2	Error on evaporator sensor
Sensor for condensor	P-C	Value for condensor sensor	F3	Error on condensor sensor
Sensor for display and alarms	P-E	Value for display and alarms sensor	F5	Error on sensor for display and alarms
			F7	Overheated condensor
			F8	Pressure safety switch has triggered by excessive pressure in the LT cooling system

Table of content

Quick Guide – BioUltra	2	General info	37
Table of content	4	Responsibility	37
Safety	5	Type/number plate	38
Before you proceed	5	Access port	39
Cabinet components	6	Door lock	40
Installation	8	Boxes and racks	41
Initial setup	8	Mount/Unmount door handle	42
Surroundings	10	Mount/unmount door handle	42
Mounting of shelves	12	Important	43
Correct use of the outer door handle	13	Disposal	44
Correct use of the inner door handles	14	Data sheet	45
Voltage-free contact	15	BioUltra UL570	45
Connection to power	16	Refrigeration circuits	49
Equipotential bonding	18	BioUltra UL570 H, air cooled, 50 Hz	49
Connection to water supply	19	BioUltra UL570 H, air cooled, 60 Hz	50
Start-up	20	BioUltra UL570 G, air cooled, 50/60 Hz	50
The digital display	20	BioUltra UL570 H, hybrid (air and water cooled) ..	51
Walkthrough of menu	21	BioUltra UL570 G, air cooled	52
Error codes	22	BioUltra UL570 G, hybrid (air and water cooled) ..	53
Local alarm settings	23	Wiring diagram	54
Local high alarm	23	BioUltra UL570	54
Local low alarm	23	Declaration of conformity	55
Local high alarm delay	24	BioUltra UL570	55
Local low alarm delay	24	General maintenance information	56
Local acoustic settings	25	Maintenance plan	57
External alarm settings	26	General cleaning information	59
External high alarm	26	Cleaning plan	60
External low alarm	26	FAQ	64
External high alarm delay	27	IQ & OQ	66
External low alarm delay	27	Installation & Operation Qualification	66
External acoustic settings	28	PQ	74
Parameter settings	29	Performance Qualification	74
Sensor offset	29	Index	86
Escorted/set alarm limits	31		
Display sensor	32		
Regular maintenance	33		
Cleaning	33		
Door gasket	34		
Defrosting the inner doors and cabinet	35		
Equalisation valve	36		

Copyright © 2006- Gram BioLine, a division of Gram Scientific ApS, Denmark. All rights reserved.

The content of this publication is owned by Gram BioLine, unless otherwise noted, and is protected by Danish and international copyright laws and provisions.

Information and images may not be used, copied or transferred without the express written permission of Gram BioLine.



Manufactured by
Gram Scientific ApS
Aage Grams Vej 1 · 6500 Vojens · Denmark
Tel: +45 73 20 13 00
e-mail: info@gram-bioline.com · www.gram-bioline.com

Before you proceed

Make sure to read the instructions for use thoroughly before using the cabinet for the first time. In the event of need for product support, do not hesitate to contact us at: support@gram-bioline.com

This instructions for use is intended for the following product series:

BioUltra

We recommend that you read this instructions for use thoroughly before using the cabinet for the first time.

Gram BioLine does not guarantee safe operation if the cabinet is used for anything other than its intended use. Contents of the instructions for use can be subject to change without notice.

No part of this instructions for use may be reproduced in any form without expressed written consent of Gram BioLine. Gram BioLine guarantees the cabinet under certain warranty conditions. Gram BioLine is in no way responsible for any loss or damage of content. This instructions for use should be considered as an integral part of the cabinet, and should be stored close to the cabinet and be easy accessible. If the instructions for use is lost, please refer to your local distributor or Gram BioLine for a replacement. For current versions of the manual, please go www.gram-bioline.com.

Intended Use

Gram BioLine BioUltra freezers are designed and manufactured to provide safe and precise storage conditions at ultra-low temperatures.

The cabinet is designed for the following operating range:

UL -86/-60 °C

at the maximum ambient temperature specified in this instructions for use, and a maximum relative humidity of 70%. The user must ensure that the cabinet is used in accordance with its intended use. Abnormal use or use conflicting with the intended use or guidelines stipulated in the product documentation can lead to: danger to patient safety, damage to stored items, damage to cabinet, and danger to user. Gram BioLine equipment is designed to be used in a system with monitored additional independent alarms to ensure timely reaction to alarms and thereby maximum item safety.

When storing valuable or temperature-sensitive materials or products, it is advisable to employ a continuously monitoring autonomous alarm system. This alarm system should be designed in a manner that allows authorised individuals to promptly detect each alarm state and take the necessary corrective actions.

Symbols used throughout the instructions for use



Hazard



Risk of fire/flammable materials



Risk of electric shock



Risk of explosion/explosive materials



Risk of material damage



Info



Risk of personal injury



ATEX information



Risk of burning/freezing

Cabinet components

This part describes the main components pertinent to the user.

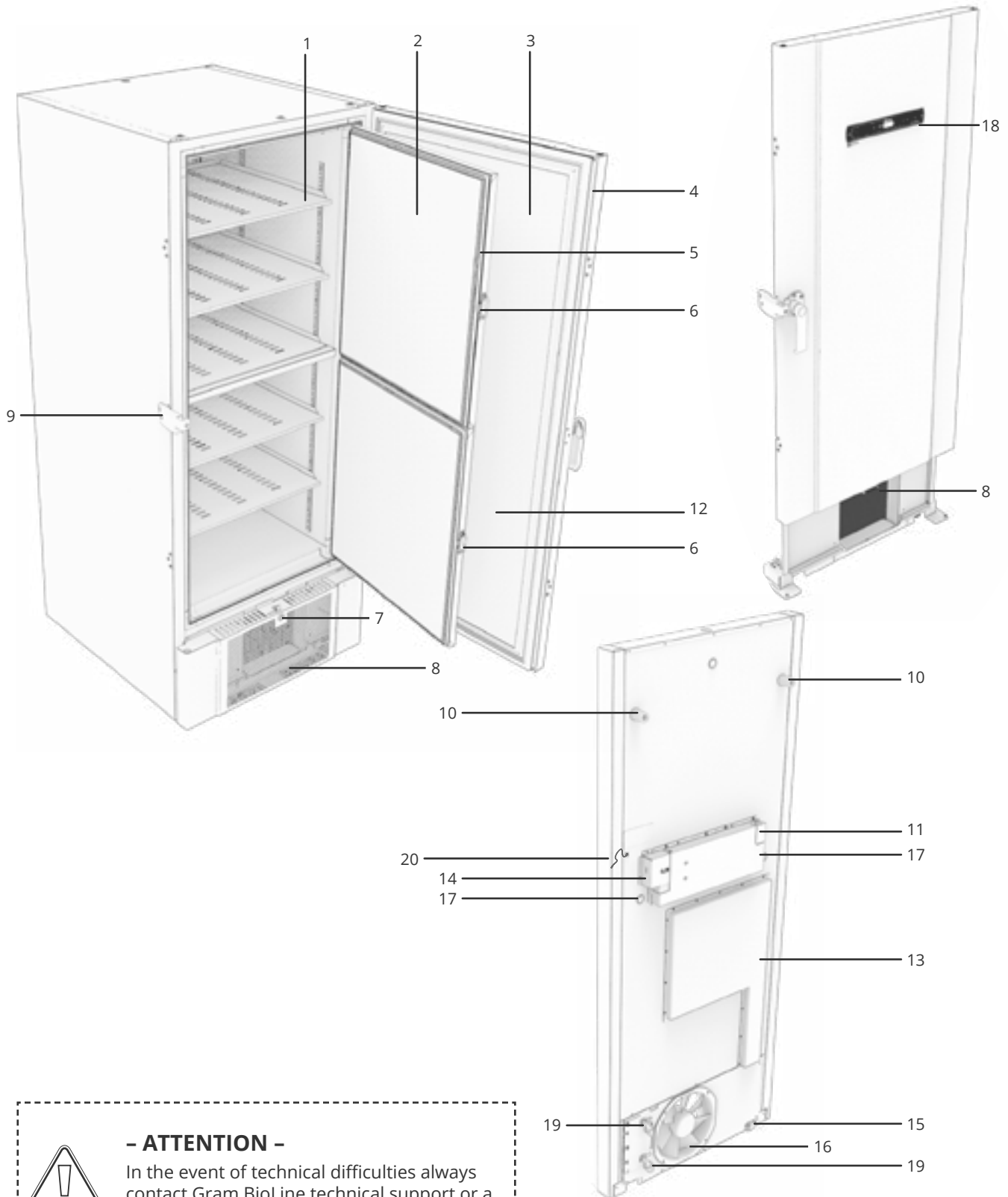

- ATTENTION -

In the event of technical difficulties always contact Gram BioLine technical support or a Gram BioLine authorised service partner.

1. **Shelves and wall rails** – Ensure that the shelves are fixed according to this instructions for use, before exerting load on them. All shelves must be supported by at least 6 shelf support clips each.
2. **Inner doors** – Ensure that the doors are closed completely after use. To minimise ice build up and fluctuations in temperature, make the door openings as brief as possible. The inner doors are removable for easy cleaning.
3. **Door** – Ensure that the door is closed completely after use. To minimise ice build up and fluctuations in temperature, make the door openings as brief as possible.
4. **Door gasket** – Ensure that the gasket is pliable and in good working order. Keep the door gasket clean, find instructions in this instructions for use.
5. **Door gaskets for inner doors** – Ensure that the gaskets are pliable and in good working order. Keep the door gaskets for inner doors clean, find instructions in this instructions for use.
6. **Latch for inner doors** – Ensure that inner doors are closed completely after use. Find instructions for operation in this instructions for use.
7. **Door lock** – Lock to secure the door.
8. **Front panel, air intake and condenser** – Do not cover the holes in the front panel. Remove the front panel to access the condenser.
9. **Door handle and backstop** – The door handle has to be in the closed position when the door is closed. Follow instructions in this instructions for use to use the handle correctly.
10. **Rubber spacers** – Are intended to ensure appropriate space between the cabinet and the wall. Do not remove.
11. **Access plate for voltage-free contact** – Use to connect to an external alarm system. Instructions for connection is found in this instructions for use. Remember to set external alarms (EAL).
12. **Pressure equalisation valve** – Do not use as access port. Keep it as free of ice as possible.
13. **Service hatch** – Use to access the drier filter and heat exchanger.
14. **Preload cover to access mains terminal connection** – Mains power connection, secured mechanically by the preload cover. Find installation guide in this instructions for use
15. **Leveling castors** – The castors allow for easy positioning, with the added stationary stability of legs once deployed. Find instructions and precautions in this instructions for use.
16. **Fan exhaust** – Do not obstruct the fan exhaust, failing to do so will lead to reduced performance or malfunction.
17. **Access port** – Use to lead sensors and similar into the cabinet. Ensure that the access port is sealed properly prior to start up.
18. **Digital display for controller** – Use the display to show the cabinet's temperature and, to set the parameters described in this instructions for use.
19. **Inlet and outlet for water cooling (if applicable)** – Applicable for water cooled, and hybrid cooled (water and air cooled) cabinets. Ensure the that there are no signs of mold or dirt before water-connection is made. Be aware that there can be droplets of test-water in the water-system.
20. **Equipotential bonding** – To ensure compliance with ATEX regulations EN 60079-14. See installation section for specifications.



– ATTENTION –

If parts show signs of damage:
do not use the cabinet and contact Gram
Bioline or supplier for further aid.

Installation

Initial setup

This part of the instructions for use describes how to setup the cabinet.



- I-1*:** Due to safety and operating considerations, the cabinet must not be used outdoors.
- I-2*:** The cabinet should be installed in a dry and sufficiently ventilated area.
- I-3*:** To ensure efficient operation, the cabinet should not be installed in direct sunlight or close to heat sources.
- I-4*:** Minimum ambient temperature: +10 °C
Maximum ambient temperature: +30 °C
Setpoint temperature: -60 °C to -86 °C



Ensure the use of correct personal protective equipment such as gloves and goggles, when handling equipment to support safe and efficient use.



- I-5*:** Avoid placement of the cabinet in a chloric/acidic environment due to risk of corrosion.



- I-6*:** The cabinet is shipped with a protective film that should be removed prior to use.



- I-7*:** Clean the cabinet with a mild soap solution prior to use.



- I-8*:** The cabinet is only allowed to lay down for very short durations (for instance handling through a doorway). If the cabinet has been laying down, the cabinet must stand up-right for at least 24 hours prior to use. This enables oil in the compressors to flow back into place.



WARNING – POTENTIAL ELECTROSTATIC CHARGING HAZARD

Removing protective packaging and film may cause electrostatic discharge. protective packaging and film shall not be removed in ATEX zones.

This part of the instructions for use describes how to adjust the levelling castors on the cabinet.

- I-9*:** When the cabinet is positioned, ensure that at least two of the legs of the cabinet are deployed. Turn the dial to either raise or lower the legs. Raising all four legs, makes it possible to move the cabinet unhindered.
- I-10-11*:** All BioUltra cabinets are equipped with multifunctional levelling castors. These allow for easy positioning, with the added stationary stability of legs once deployed.

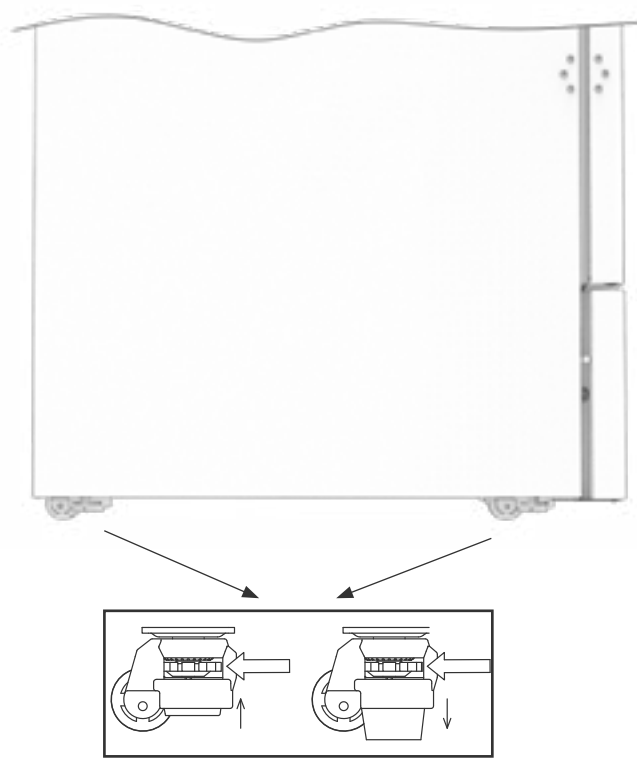

Remember to disconnect the cabinet from the power supply before moving it.



All lifting of the cabinet must be done by mechanical lifting equipment. Lifting by hand can result in injury.



A visual inspection of the cabinet must be conducted prior to putting the cabinet into service. Check the cabinet's structural integrity, that door frames and doors do not have deformities, that the gaskets seal properly and that the doors sit flush up against the door frames.

Surroundings



I-13*: The cabinet must always be placed a minimum of 50 mm from the wall while in use. Allowing warm exhaust air from the compressor room to dissipate. The cabinet must also have a minimum of 30 mm gap between cabinet sides and/or walls.

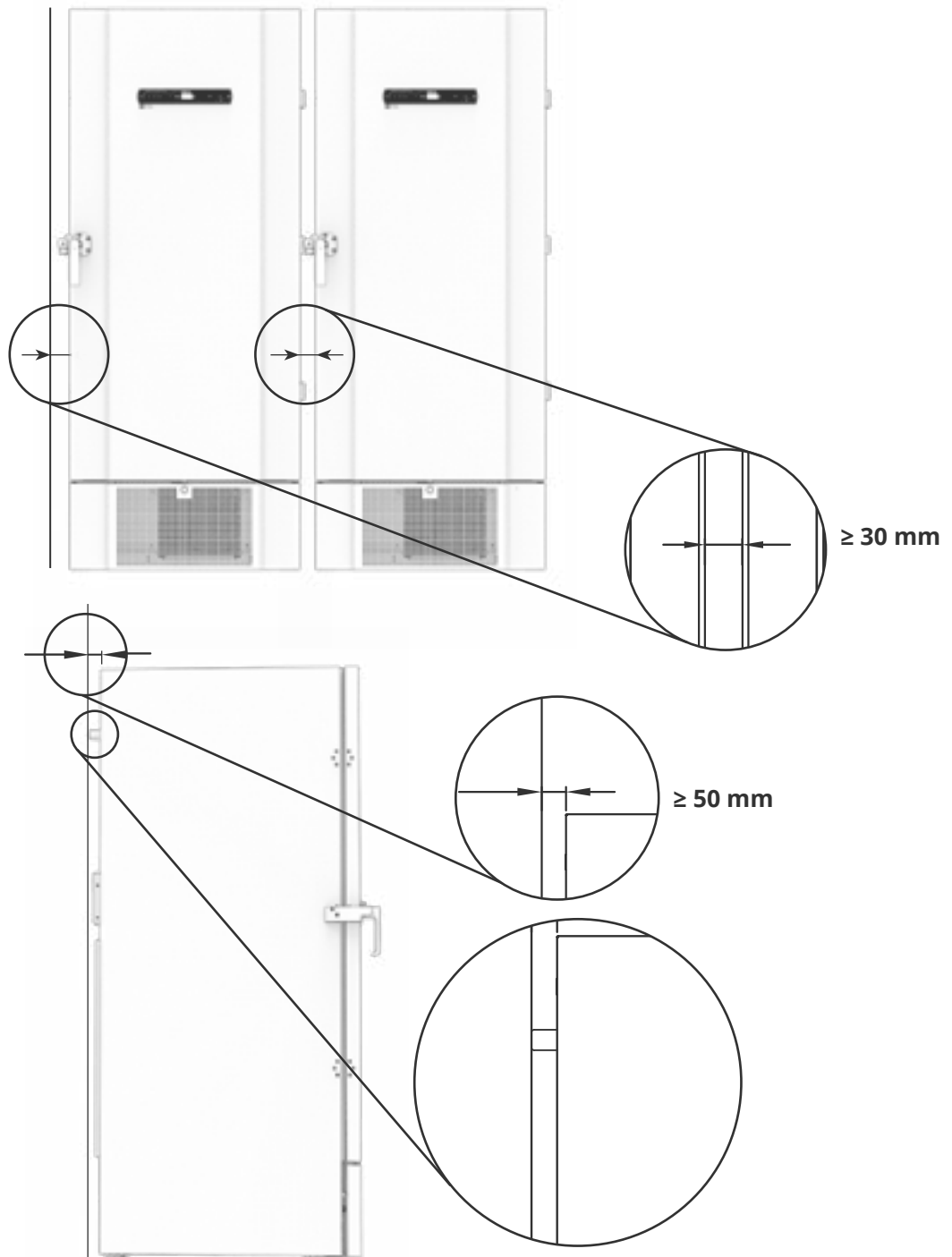



I-14*: Do not cover the holes in the front panel of the cabinet.



I-15*: Do not use electrical appliances inside the cabinet.



The cabinet is not suited for storing items that emit vapours, as they might corrode the cabinet and its components.

All items in the cabinet that are not encapsulated, or wrapped, should be covered to reduce the risk of corrosion of the cabinet and its components.



- For Ex environments -

Open containers inside the storage chamber may impact the ATEX Zone classification



- For Ex environments -

Special conditions for safe use may apply to this product when installing in an EN 60079-14 environment. Please see corresponding Ex certificate for specifications.



Do not remove the rubber spacers on the back of the cabinet, as they ensure the minimum required distance from the fan exhaust to the wall.

Mounting of shelves

This part of the instructions for use covers mounting and rearranging of the shelving in the cabinet.

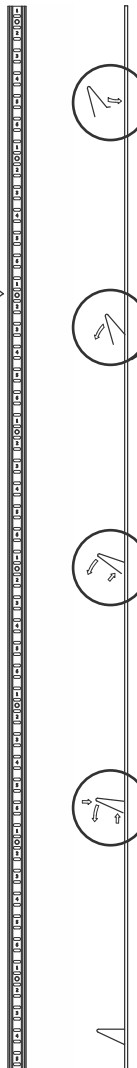

I-16*: Mount the shelf support clips to the wall rails, using the numbering on the wall rails to determine the right shelf height. Finally placing the shelf on the supports on the support clips.

Mount the clip by firstly slotting the protrusion on the horizontal part of the clip into the wall rail. While the protrusion is cradled in position, turn the clip down and inwards.

When turning the clip downwards, compress the diagonal strut of the clip, thereby allowing the protrusion on the diagonal strut to rest in the appropriate hole on the wall rail.

After mounting the shelf support clips, lay the shelf on top of the clips.

Ensure that the shelf is safely mounted before exerting load on them.



All shelves must be supported by at least 6 shelf support clips each.



Touching any part of a cold cabinet with wet hands can cause frost burns.



Changing the interior configuration must only be conducted when the cabinet is turned off, and when the cabinet is at room temperature

Correct use of the outer door handle

This part covers the correct use of the outer door handle. Read the following part thoroughly before using the cabinet.

I-17*: It is important for safe operation and performance that the door is closed entirely when items in the cabinet are not being accessed.

Do not slam the door, as this can cause material damage.



A vacuum can be created in the storage space after closing the door, please allow the cabinet to equalise in pressure before attempting to open the door again. Attempting to open the door before adequate equalisation can result in material damage.



Ensure that there is a proper seal between gasket and door frame when the door is closed and the handle is in the closed position.



The outer door handle must not be closed before securing that the inner doors are closed correctly.

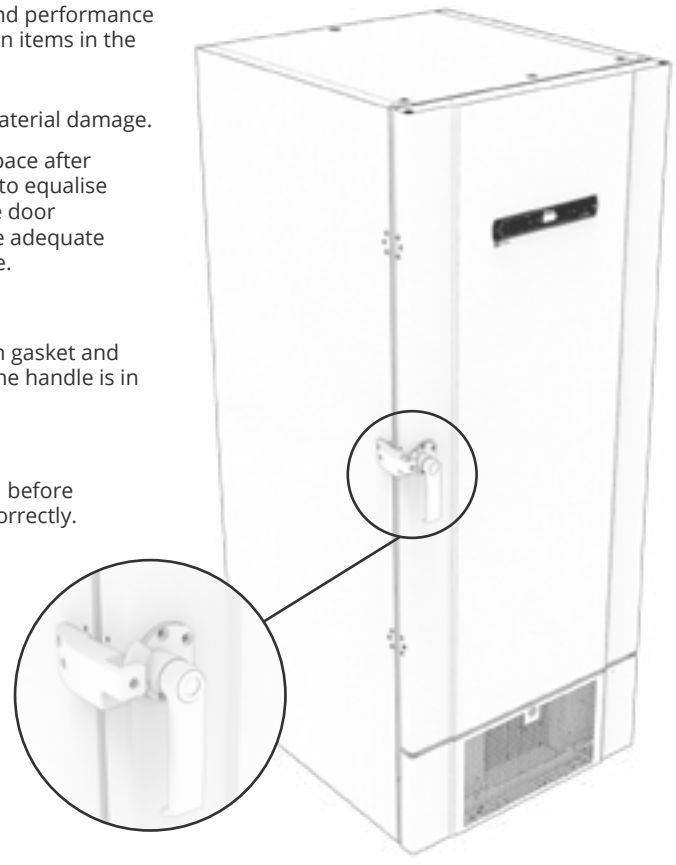

i Please note: The door is not fully closed until the handle is pointing down, as shown in the illustration below.



Open



Neutral

Neither open nor closed



Closed

**) Paragraph designation (I-1, I-2 etc) refers to the IQ (Installation Qualification)*

Correct use of the inner door handles

This part covers the correct use of the inner door handles. Read the following part thoroughly before using the cabinet. The inner doors are designed to operate, close and mount/unmount independently.

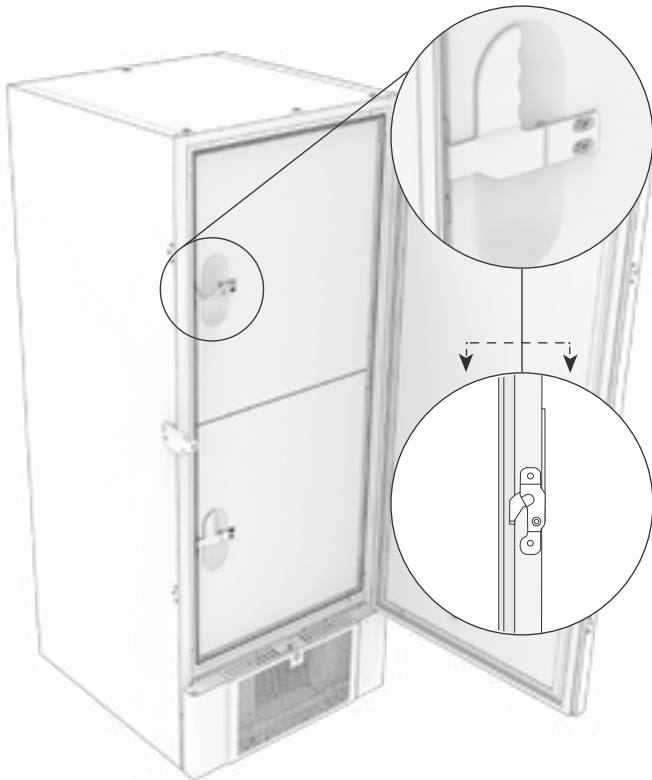

I-18*: The inner doors are locked when the door lever clicks in place and sits flush up against the inner door.

The illustration on the left shows the inner doors in the closed position.

The inner doors are opened by pulling the door lever straight downwards until the door latch disengages, then open the door normally.

The illustration below shows the process of opening an inner door.

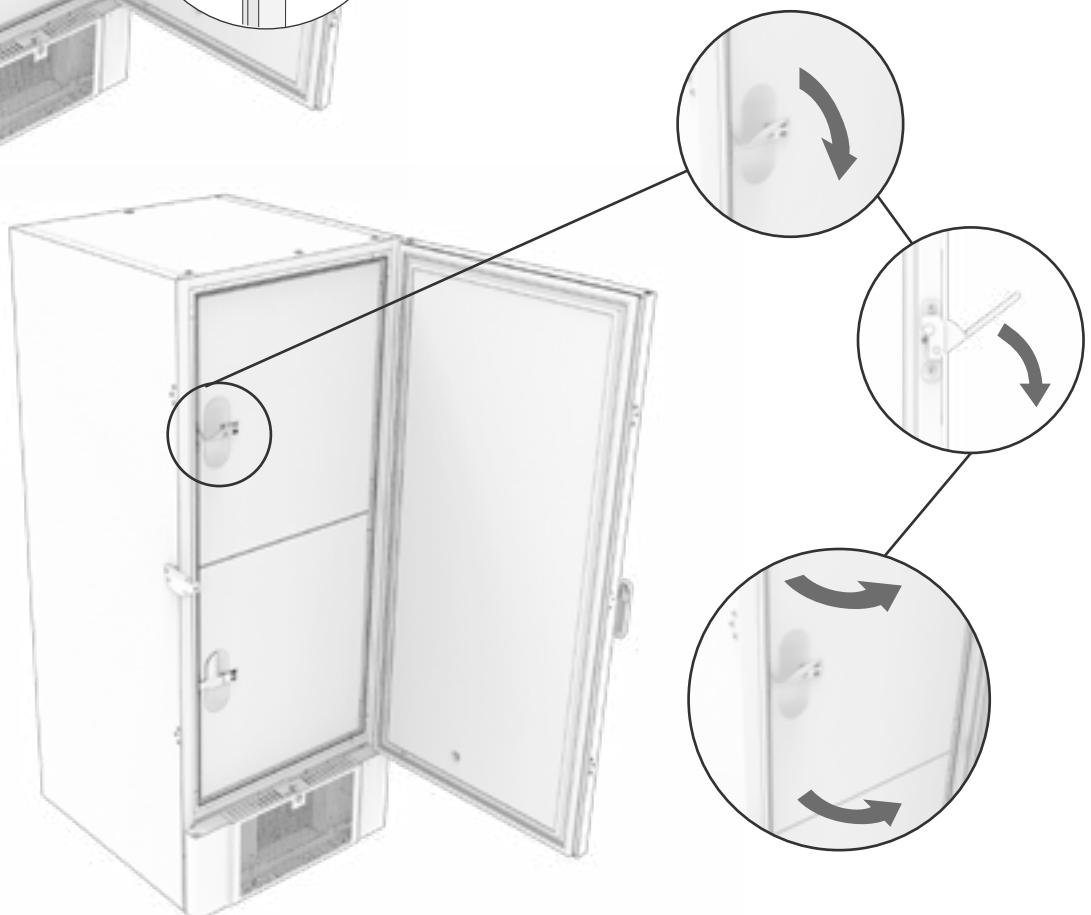

Always ensure that the door gaskets are in good condition, and that the gaskets seal properly.

Voltage-free contact

This part of the instructions for use covers the voltage-free contact.

The illustration below shows the three connectors for the relay (used e.g. in connecting to CTS or other external alarm systems). The three connections, are respectively. Common, NO and NC.

The moment when voltage is applied the controller draws the relay, this makes it possible for the controller to respond to both high and low temperature alarms and power failures. Temperature alarms must be configured in the external alarm settings (EAL) before they will activate the voltage-free contact. Find instructions on setting external alarms in the parameter settings section.

The wires that are connected to the connection block for the voltage-free contact, are secured in place by a cable tension relief and a securing plate that is screwed in place. This secures that there is no tension on the connection block and prevents access to the electrical circuit.

Connection of the voltage-free contact should be done by a qualified installer.

Normally closed circuit (NC)

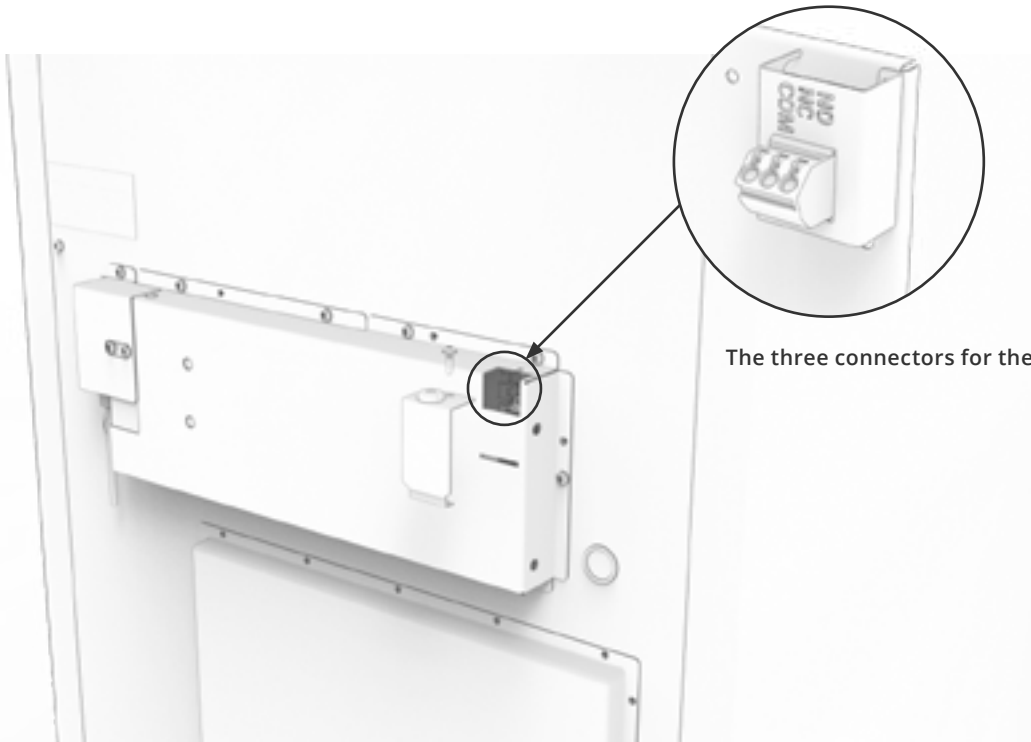
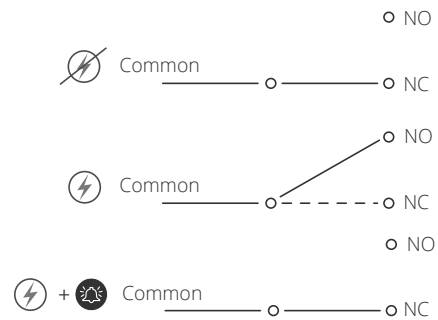

The three connectors for the relay

Connection to power

Read the following part thoroughly before connecting the cabinet. Contact a qualified electrician if in doubt.

I-19*: When setting up in an ordinary scenario that is not subject to regulations for EN 60079-15 zone 2:

The appliance may be connected in accordance with applicable local heavy current regulations.

Note that there are special regulations for products that are in accordance with EN 60079-15 zone 2 and EN 60079-14: Explosive atmospheres – Electrical installations design, selection and erection.

The appliance has been manufactured in accordance with EN 60079-15: Electrical apparatus for explosive gas atmospheres – Part 15: Type of protection II 3G Ex ec nC ic IIB Tx Gc. Zone 2 is the applicable zone. If the appliance is to be installed in a zone 2 environment, specialist personnel should perform the installation, or be consulted beforehand, in order to ensure that the appliance is installed in compliance with the guidelines currently contained in the standard.

The cabinet is intended for connection to alternating current. The connection values for voltage (V) and frequency (Hz) are given on the type/number plate.

I-20-1*: The mains terminal is accessed via the preload cover as shown on the back of the freezer. Unscrew the preload cover to access the mains supply terminal. Ensure that the preload cover is reinstalled after plugging in the power cord. The leaf spring in the preload cover must engage and preload the plug of the cord as shown in the illustrations below. Ensure that the mains plug is seated completely in the terminal on the cabinet.

The appliance must be connected to the external power supply using a suitable device which mechanically prevents the plug and socket from being separated unintentionally.

I-21*: The connection must be labelled: **"DO NOT SEPARATE WHEN ENERGIZED"**

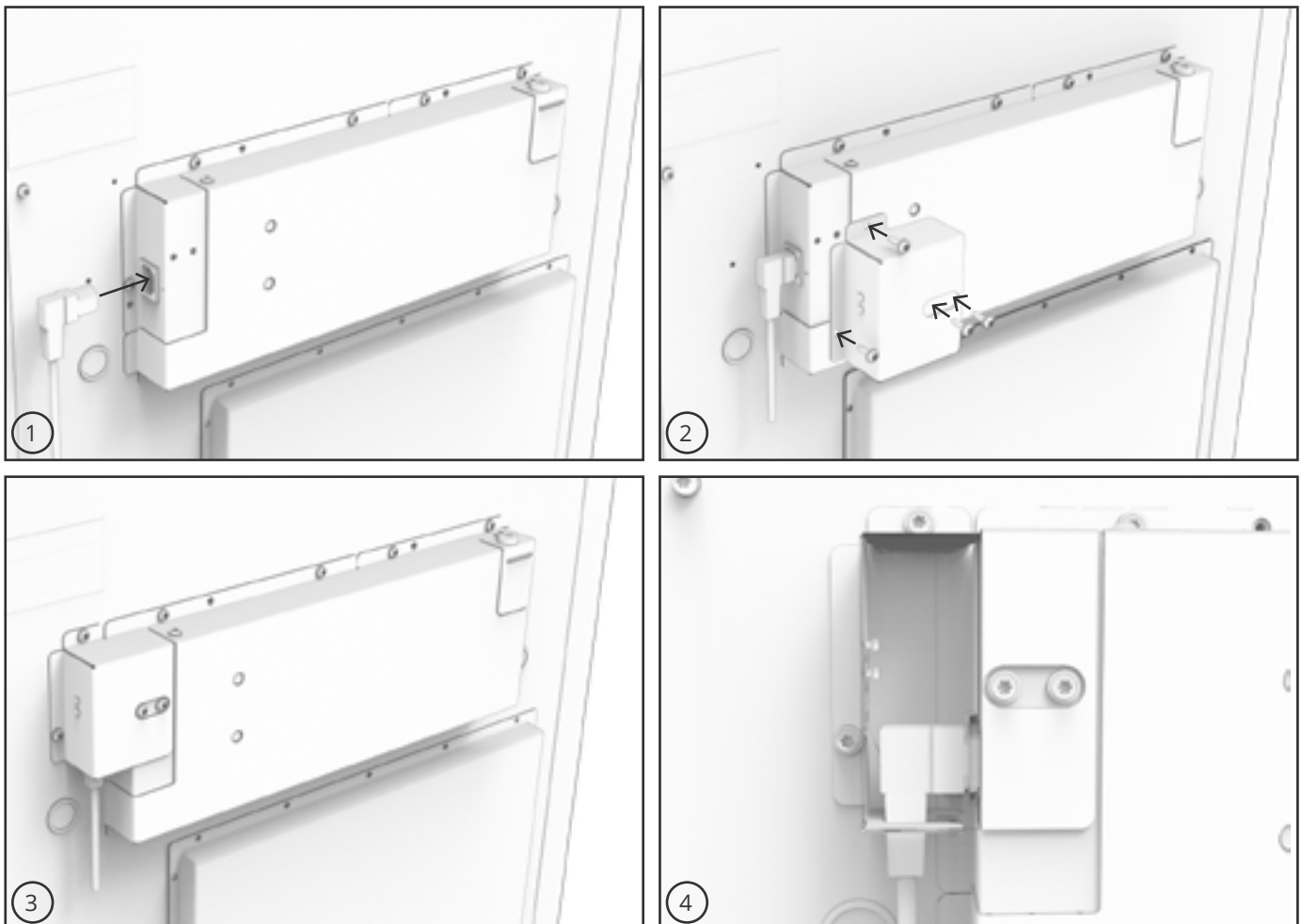

– ATTENTION –

Fuses and similar must never be removed or replaced while the appliance is connected to a power source.

The electrical terminal box must never be opened while the appliance is connected to a power source.

The compressor's starting equipment must never be dismantled while the appliance is connected to a power source.

Whenever electrical components are dismantled or replaced, the appliance must be moved to an area in which there is no risk of ignition caused by the electrical components or gases contained in the appliance.

Never use the cabinet if the plug is damaged. The cabinet should be examined by a Gram BioLine service technician in such cases.

When setting up in an ordinary scenario that is not subject to regulations for Zone 2:

The appliance may be connected in accordance with applicable local heavy current regulations.

In both cases

Use a three-wire plug, if the power outlet is intended for a three-wire plug, the lead in green/yellow insulation should be connected to the ground terminal.

Power must be connected via a wall socket. The wall socket should be easily accessible.

All earthing requirements stipulated by the local electricity authorities must be observed. The cabinet plug and wall socket should then have correct earthing. If in doubt, contact your local supplier or authorised electrician.



– For Ex environments –

Special conditions for safe use may apply to this product when installing in an EN 60079-14 environment. Please, see corresponding Ex certificate for specifications.

– Technical Support –

In the event of technical difficulties always contact Gram BioLine technical support or a Gram BioLine authorised service partner. Never dismantle the terminal box or any other electrical component.

Equipotential bonding

This part of the instructions for use describes the connection for the equipotential bonding.



I-22-1*: For installation in ATEX Cat. 3 Zone 2 areas, it is mandatory to have a equipotential bonding, it is not sufficient to use protective earth through the mains connection.

To secure equipotential bonding of the unit – The mounted external bonding conductor must be used in accordance with national installation requirements e.g. EN 60079-14.

- Mounting of the bonding conductor should be done according to the following illustrations.
- Please find location for connection facilities on the back of the cabinet marked with: **“Attention – Equipotential bonding”**.
- The bonding conductor should be at least 4 mm² guage thickness.
- Use a ring terminal to ensure adequate bonding.
- Use the supplied M5 machine screw and washer to attach the bonding conductor to the cabinet. Tighten the machine screw to 3.2 Nm.

Bonding of the cabinet is illustrated on this page.

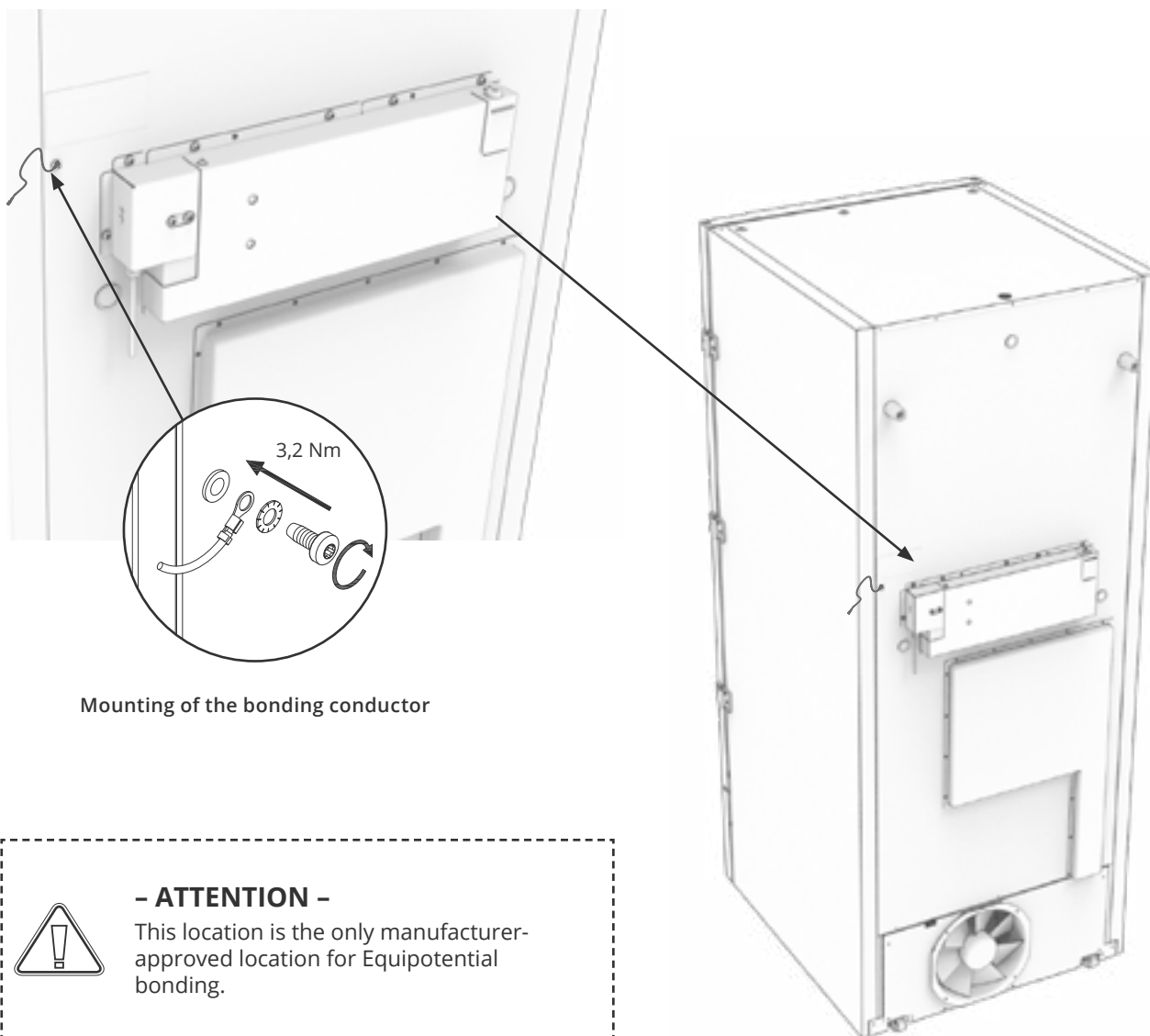

Mounting of the bonding conductor

- ATTENTION -

This location is the only manufacturer-approved location for Equipotential bonding.

Connection to water supply

Applicable for water cooled and hybrid cooled (air and water cooled) cabinets. When performing the regular maintenance on the cabinet, please check all connections for the water-cooling system and make sure there are no leaks.

Water cooled or hybrid cooled means that a cabinet is connected to a water supply whereby the heat generated from the cabinet is carried away by the facility process water distribution system for utilisation in other parts of the facility. As added safety the hybrid cooled has an air-cooled condenser in the event of malfunction of the facility process water supply.

For connection to the water supply please use the inlets/outlet illustrated below. Please be aware of the direction of feed in/out according to illustration below.



Connection of the water supply must be done by a qualified installer and made in accordance with local legislation and guidelines. Interfaces for water connection is ½" pipes with external metric coarse thread (male).

The recommended temperature of the water supply should be from +12 °C to +7 °C, and maximum 30 °C.



The recommended water flow pressure is 0.5 to 1 bar. Maximum operating water pressure must not exceed 10 bar.

Recommended particle size in water feed may not be greater than 1 mm (0.04"). A strainer with a size of 16-20 mesh (number of openings per inch) shall be installed before the water feed inlet to protect the cabinet and its functionality.

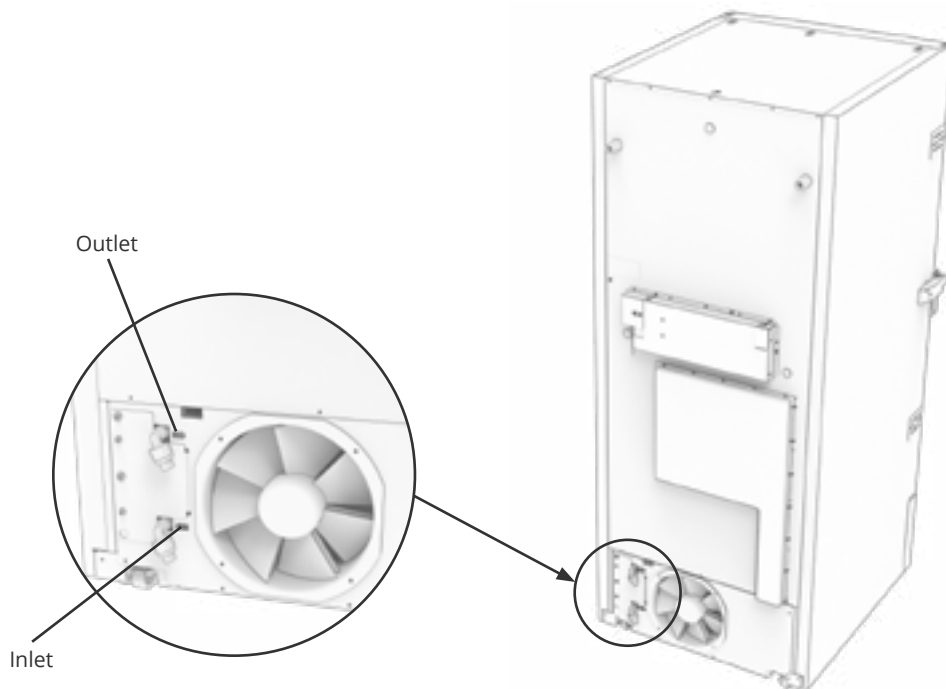

– ATTENTION –

When connected to the water supply the cabinet must not be moved.

Please be aware, water leaks must not occur.

Start-up

The digital display

The digital display depicted below, shows the cabinet's temperature and indicates if the cabinet is connected to a power source.

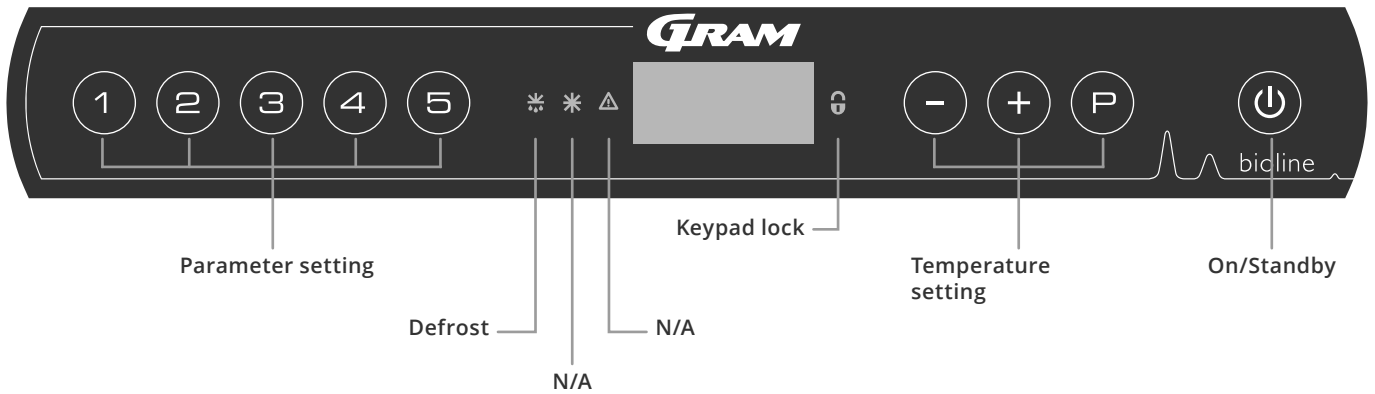

O-1*: On/Standby

Press to turn the cabinet on. Press for 6 seconds to turn the cabinet to standby. The software version of the cabinet will be shown when turning the cabinet on, followed by the software variant. The cabinet is ready when the temperature is displayed.

The cabinet will always commence operation when initially connected to a power supply. For instance after a power outage or when plugging the cabinet in for the first time.

- **Parameter setting**
Gives access to the cabinet's configurable parameters, such as alarms, test programs and sensor values.
- **Defrost**
Defrost in progress on the heat exchanger.
- **Keypad lock**
Keypad is locked, no access to functions or menus.
- **Temperature setting**
Setting of the temperature setpoint and navigation in the menus.
- **On/Standby**
Turn the cabinet on or switch to standby, and navigation in the menus.

O-2*: Temperature setting

Temperature adjustments are done by holding and pressing either or . Confirm the settings by letting go of the keys.

- ATTENTION -

Make sure the cabinet is switched off at the socket before service is performed on electrical parts.



It is not sufficient to switch off the cabinet on the key, as current will persist in some electrical parts of the cabinet. If fuses or similar are to be replaced, the cabinet must be moved to a no-risk area.

- For Ex environments -

DO NOT OPEN, MAINTAIN OR SERVICE IN AN AREA WHEN AN EXPLOSIVE ATMOSPHERE IS PRESENT



- ATTENTION -

High and low temperature alarms set up in the cabinets' controller (including EAL alarms) must be accompanied by additional redundant independent external alarms to ensure maximum item safety.



All-round introduction to navigating the menus

Beyond setting the temperature and on/standby, , , , and is used to navigate the menus and set the parameters for the cabinet.

The keys have the following functions in the menus:

- Open a menu step or confirm a set value in the parameter settings.
- Scroll upwards in a given menu or raise a given value in parameter settings (alarm limit for instance).
- Scroll downwards in a given menu or lower a given value in parameter settings (alarm limit for instance).
- Go back a step in the menus.

Walkthrough of menu

The menu below gives a quick overview of the parameter settings for the cabinet.

User menu

Menu Access $\text{P} + \text{1} \rightarrow$	\downarrow	\rightarrow		
Local alarm settings	LAL	LhL	[° C]	Upper alarm limit. Code for activated alarm [A2]
		LLL	[° C]	Lower alarm limit. Code for activated alarm [A3]
		Lhd	[min.]	Delay of upper alarm limit
		LLd	[min.]	Delay of lower alarm limit
		BU	On/off	Acoustic signal for alarm codes [A2] and [A3]. [1=on/0=off]
External alarm settings	EAL	EhL	[° C]	Upper alarm limit. Code for activated alarm [A4]
		ELL	[° C]	Lower alarm limit. Code for activated alarm [A5]
		Ehd	[min.]	Delay of upper alarm limit
		ELd	[min.]	Delay of lower alarm limit
		BU	On/off	Acoustic signal for external alarm codes [A4], [A5]. [1=on/0=off]
Offset of sensors	cAL	CA	[° K]	Offset of A-sensor. Reference sensor for the refrigeration system
		CE	[° K]	Offset of E-sensor. Reference sensor for the display and alarms
	ALL			Activation of escorted alarm limits. [FAS]=locked limits/[ESC]=follows setpoint
	dPS			Reference sensor for the display (A or E) (E is factory setting)

Other Shortcuts

Keys	Duration	Function
$\text{P} + \text{⏻}$	> 3 seconds	Start or stop a defrost of the heat exchanger
$\text{⏻} + \text{1}$	> 6 seconds	Activating/deactivating the keypad lock
P	-	Shows the temperature setpoint value
+	-	Shows the highest registered temperature spike (since the last reset of the alarm history)
-	-	Shows the lowest registered temperature spike (since the last reset of the alarm history)
$\text{+} + \text{-}$	> 3 seconds	Reset of the alarm history
$\text{P} + \text{1} + \text{3}$	> 6 seconds	Reset of the set parameters. Restores to the factory settings
$\text{P} + \text{1}$	> 3 seconds	Access to the user menu and alarm settings

Error codes

The following table covers the different error codes that might occur

Display code	Explanation
[A2]	Local upper alarm LhL is or has been activated.
[A3]	Local lower alarm LLL is or has been activated.
[A4]	External upper alarm EhL is or has been activated.
[A5]	External lower alarm ELL is or has been activated.
F1	Error on sensor for refrigeration system. The refrigeration system will use an emergency program to make the cabinet run. Temperature stability will be affected. Service is required.
F2	Error on the evaporator sensor. Service is required. NOTE: F2 fault can occur at start-up. Please ignore for 10-15 minutes.
F3	Error on the condenser sensor. Service is required.
F5	Error on sensor for display and alarms. Service is required.
F7	F7 indicates that the temperature of the condenser is too high. Turn off the cabinet and check that the condenser is not covered by undesirable items, and insure that the condenser (and possibly filter) is clean. Service is required if the problem is not alleviated.
F8	Pressure safety switch has triggered by excessive pressure in the LT cooling system.

Acknowledge an acoustic alarm

Temperature alarm codes [A2] and/or [A3]: Flashes in the display. Press P to acknowledge.

The display will continue to flash if the temperature is outside the alarm limits.

Latching alarms: [A2], [A3], [A4], [A5]

Due to the potential implications of alarms, the red alarm triangle icon will turn on along with the corresponding alarm code flashing in the display. The alarm state will remain on until acknowledged by pressing P .

Reading the alarm history - Example [A2]

[A2] Flashes in the display – The temperature has exceeded the set value for the upper temperature limit, LhL.

Press P to acknowledge the [A2]. The display continues to flash, indicating that there is information in the alarm history. Press + , Htt (High temperature time) is shown. Press P to see for how long the temperature was above the set alarm limit. Press U to return to Htt. Press + to reach Ht (Highest temperature). Press P to read the highest recorded temperature during Htt. Press U to return to Ht and press U again to leave the alarm history.

The procedure for reading an [A3] alarm is identical, apart from entering the alarm history with - . When reading out temperatures below set limits, the parameters are Ltt and Lt.

A flashing display with no alarm codes indicates that the alarm codes have been acknowledged, but the alarm history contains information.

Resetting the alarm temperature and the alarm history

Resetting of the max./min. and the alarm history is done by holding - and + for more than 3 seconds, an acoustic signal will be given when reset is complete.

Local high alarm Local low alarm

The following part covers the setting of the upper and lower temperature alarm limits.

O-3*: LhL – Setting the upper alarm limit [° C]

- ↳ Press and hold **(P)** + **(1)** for more than 3 seconds. "LAL" is shown in display
- ↳ Press **(P)** to select "LAL". "LhL" is now shown in the display
- ↳ Press **(P)** to select "LhL". The upper alarm limit is now shown in the display
- ↳ Press **(+)** or **(-)** to set the desired value for the upper alarm limit
- ↳ Press **(P)** to confirm the set value
 - The upper alarm limit is now set, proceed to other parameters by pressing **(⏏)**, then navigate by using **(+)** or **(-)**.
- ↳ Leave the user menu by pressing **(⏏)** several times until the cabinet's temperature is shown in the display

O-4*: LLL – Setting the lower alarm limit [° C]

- ↳ Press and hold **(P)** + **(1)** for more than 3 seconds. "LAL" is shown in display
- ↳ Press **(P)** to select "LAL". "LhL" is now shown in the display
- ↳ Press **(+)** to proceed to "LLL"
- ↳ Press **(P)** to select "LLL". The lower alarm limit is now shown in the display
- ↳ Press **(+)** or **(-)** to set the desired value for the lower alarm limit
- ↳ Press **(P)** to confirm the set value
 - The lower alarm limit is now set, proceed to other parameters by pressing **(⏏)**, then navigate by using **(+)** or **(-)**.
- ↳ Leave the user menu by pressing **(⏏)** several times until the cabinet's temperature is shown in the display



- ATTENTION -

High and low temperature alarms set up in the cabine's controller (including EAL alarms) must be accompanied by additional redundant independent external alarms to ensure maximum item safety.

Local high alarm delay

Local low alarm delay

The following part covers the setting of the delay for the local upper and lower temperature alarm limits.

O-5*: Lhd – Setting the delay of the local upper alarm limit [min.]

- ↳ Press and hold (P) + (1) for more than 3 seconds. "LAL" is shown in display
- ↳ Press (P) to select "LAL". "LhL" is now shown in the display
- ↳ Press (+) several times until "Lhd" is shown in the display
- ↳ Press (P) to select "Lhd". The delay of the upper alarm limit is now shown in the display
- ↳ Press (+) or (-) to set the desired value for the delay of the upper alarm limit
- ↳ Press (P) to confirm the set value
 - The delay of the upper alarm limit is now set, proceed to other parameters by pressing (⏏), then navigate by using (+) or (-)
- ↳ Leave the user menu by pressing (⏏) several times until the cabinet's temperature is shown in the display

O-6*: LLd – Setting the delay of the local lower alarm limit [min.]

- ↳ Press and hold (P) + (1) for more than 3 seconds. "LAL" is shown in display
- ↳ Press (P) to select "LAL". "LhL" is now shown in the display
- ↳ Press (+) several times until "LLd" is shown in the display
- ↳ Press (P) to select "LLd". The delay of the lower alarm limit is now shown in the display
- ↳ Press (+) or (-) to set the desired value for the delay of the lower alarm limit
- ↳ Press (P) to confirm the set value
 - The delay of the lower alarm limit is now set, proceed to other parameters by pressing (⏏), then navigate by using (+) or (-)
- ↳ Leave the user menu by pressing (⏏) several times until the cabinet's temperature is shown in the display



- ATTENTION -

High and low temperature alarms set up in the cabinet's controller (including EAL alarms) must be accompanied by additional redundant independent external alarms to ensure maximum item safety.

Local acoustic settings

The following part covers the setting of the acoustic local alarms.

O-9*: BU – Activation/deactivation of the acoustic local alarms

- ↳ Press and hold $\text{P} + \text{1}$ for more than 3 seconds. "LAL" is shown in display
- ↳ Press P to select "LAL". "LhL" is now shown in the display
- ↳ Press + several times until "BU" is shown in the display
- ↳ Press P to select "BU".
- ↳ Press + or - to activate/deactivate the local acoustic alarms [1=activated/0=deactivated]
- ↳ Press P to confirm the set value
 - The local acoustic alarms is configured, proceed to other parameters by pressing P , then navigate by using + or - .
- ↳ Leave the user menu by pressing P several times until the cabinet's temperature is shown in the display



- ATTENTION -

High and low temperature alarms set up in the cabinet's controller (including EAL alarms) must be accompanied by additional redundant independent external alarms to ensure maximum item safety.

External alarm settings

External high alarm External low alarm

The following part covers the setting of upper and lower external temperature alarm limits.

O-10*: EhL – Setting the external upper alarm limit [° C]

- ↳ Press and hold **(P)** + **(1)** for more than 3 seconds. "LAL" is shown in display
- ↳ Press **(+)** several times until "EAL" is shown in the display
- ↳ Press **(P)** to select "EAL". "EhL" is now shown in the display
- ↳ Press **(P)** to select "EhL". The external upper alarm limit is now shown in the display
- ↳ Press **(+)** or **(-)** to set the desired value for the external upper alarm limit
- ↳ Press **(P)** to confirm the set value
 - The external upper alarm limit is now set, proceed to other parameters by pressing **(⏏)**, then navigate by using **(+)** or **(-)**
- ↳ Leave the user menu by pressing **(⏏)** several times until the cabinet's temperature is shown in the display

O-11*: ELL – Setting the external lower alarm limit [° C]

- ↳ Press and hold **(P)** + **(1)** for more than 3 seconds. "LAL" is shown in display
- ↳ Press **(+)** several times until "EAL" is shown in the display
- ↳ Press **(P)** to select "EAL". "EhL" is now shown in the display
- ↳ Press **(+)** to proceed to "ELL"
- ↳ Press **(P)** to select "ELL". The external lower alarm limit is now shown in the display
- ↳ Press **(+)** or **(-)** to set the desired value for the external lower alarm limit
- ↳ Press **(P)** to confirm the set value
 - The external lower alarm limit is now set, proceed to other parameters by pressing **(⏏)**, then navigate by using **(+)** or **(-)**
- ↳ Leave the user menu by pressing **(⏏)** several times until the cabinet's temperature is shown in the display



- ATTENTION -

High and low temperature alarms set up in the cabinet's controller (including EAL alarms) must be accompanied by additional redundant independent external alarms to ensure maximum item safety.

External high alarm delay External low alarm delay

The following parts covers the setting of the delay of the external upper and lower alarms.

O-12*: Ehd – Setting the delay of the external upper alarm limit [min.]

- ↳ Press and hold **(P)** + **(1)** for more than 3 seconds. "LAL" is shown in display
- ↳ Press **(+)** to proceed to "EAL"
- ↳ Press **(P)** to select "EAL". "EhL" is now shown in the display
- ↳ Press **(+)** several times until "Ehd" is shown in the display
- ↳ Press **(P)** to select "Ehd". The external delay of the upper alarm limit is now shown in the display
- ↳ Press **(+)** or **(-)** to set the desired value for the external delay of the upper alarm limit
- ↳ Press **(P)** to confirm the set value
 - The delay of the external upper alarm limit is now set, proceed to other parameters by pressing **(⏻)**, then navigate by using **(+)** or **(-)**
- ↳ Leave the user menu by pressing **(⏻)** several times until the cabinet's temperature is shown in the display

O-13*: ELd – Setting the delay of the external lower alarm limit [min.]

- ↳ Press and hold **(P)** + **(1)** for more than 3 seconds. "LAL" is shown in display
- ↳ Press **(+)** to proceed to "EAL"
- ↳ Press **(P)** to select "EAL". "EhL" is now shown in the display
- ↳ Press **(+)** several times until "ELd" is shown in the display
- ↳ Press **(P)** to select "ELd". The delay of the external lower alarm limit is now shown in the display
- ↳ Press **(+)** or **(-)** to set the desired value for the delay of the lower alarm limit
- ↳ Press **(P)** to confirm the set value
 - The delay of the external lower alarm limit is now set, proceed to other parameters by pressing **(⏻)**, then navigate by using **(+)** or **(-)**
- ↳ Leave the user menu by pressing **(⏻)** several times until the cabinet's temperature is shown in the display



- ATTENTION -

High and low temperature alarms set up in the cabinet's controller (including EAL alarms) must be accompanied by additional redundant independent external alarms to ensure maximum item safety.

External acoustic settings

The following part covers the setting of the acoustic external alarms.

O-16*: BU – Activation/deactivation of the acoustic external alarms

- ↳ Press and hold $\text{P} + \text{1}$ for more than 3 seconds. "LAL" is shown in display
- ↳ Press + to proceed to "EAL"
- ↳ Press P to select "EAL". "EhL" is now shown in the display
- ↳ Press + several times until "BU" is shown in the display
- ↳ Press P to select "BU"
- ↳ Press + or - to activate/deactivate the external acoustic alarms [1=activated/0=deactivated]
- ↳ Press P to confirm the set value
 - The external acoustic alarms is configured, proceed to other parameters by pressing P , then navigate by using + or -
- ↳ Leave the user menu by pressing P several times until the cabinet's temperature is shown in the display



- ATTENTION -

High and low temperature alarms set up in the cabinet's controller (including EAL alarms) must be accompanied by additional redundant independent external alarms to ensure maximum item safety.

Sensor offset

The following part covers the offset of the A- and E-sensor.

The temperature sensors connected to the MPC controller can be off-set independently of each other in the parameter cAL. Offset is used in cases where there are deviations in the cabinet's actual temperature compared to the temperature shown in the display and/or control measurements by independent temperature monitoring.

The cabinet is equipped with a sensor (A-sensor) and an extra sensor (E-sensor).

The A-sensor is used to manage the cabinet's refrigeration system and is fixated in a given position in the cabinet. The location of the A-sensor must not be altered.

The E-sensor is placed in the cabinet's storage space. The E-sensor is the default display sensor and reference for the alarms. The E-sensor has no effect on operation of the refrigeration system.

The A-sensor is offset if the actual temperature in the cabinet does not match the setpoint, despite taking the hysteresis into consideration. Offset of A sensor is named "cA".

The E-sensor is offset if the actual temperature in the cabinets display, provided that the display sensor for reference is the E-sensor, does not match the independent temperature monitoring used for control. Offset of E-sensor is named "cE".

Practical example of offset:

Example 1

The temperature in the cabinet is operating warmer than the actual setpoint.

With a setpoint of -80 °C, the actual temperature inside the cabinet is between -78 °C and -80 °C. The desired temperature range is between -79 °C and -81 °C. This means that "cA", in this case, should be +1.0K, so that the refrigeration system stops 1.0K later and starts 1.0K earlier than the setpoint normally otherwise would dictate.

Example 2

The temperature in the cabinet is operating colder than the actual setpoint.

With a setpoint of -80 °C, the actual temperature inside the cabinet is between -80 °C and -82 °C. The desired temperature range is between -79 °C and -81 °C. This means that "cA", in this case, should be -1.0K, so that the refrigeration system stops 1.0K earlier and starts 1.0K later than the setpoint normally otherwise would dictate.

Offset of the A-sensor

- ↳ Press and hold $\text{P} + \text{1}$ for more than 3 seconds
- ↳ Press + several times until "cAL" is shown in the display
- ↳ Press P to select "cAL". "cA" is shown in the display
- ↳ Press P to select "cA"
- ↳ Press + or - to offset the A-sensor
- ↳ Press P to confirm the set value
 - The A-sensor is now offset, proceed to other parameters by pressing P , then navigate by using + or -
- ↳ Leave the user menu by pressing P several times until the cabinet temperature is shown in the display

Offset of the E-sensor

- ↳ Press and hold $\text{P} + \text{1}$ for more than 3 seconds
- ↳ Press + several times until "cAL" is shown in the display
- ↳ Press P to select "cAL". "cA" is shown in the display
- ↳ Press + until "cE" is shown in the display
- ↳ Press P to select "cE"
- ↳ Press + or - to offset the E-sensor
- ↳ Press P to confirm the set value
 - The E-sensor is now offset, proceed to other parameters by pressing P , then navigate by using + or -
- ↳ Leave the user menu by pressing P several times until the cabinet temperature is shown in the display

Escorted/set alarm limits

The following part covers the setting of the escorted or set alarm limits.

ALL – Setting of escorted/set alarm limits

- ↳ Press and hold $\text{P} + \text{1}$ for more than 3 seconds
- ↳ Press + several times until “ALL” is shown in the display
- ↳ Press P to select “ALL”
- ↳ Press + or - to select set (FAS) or escorted (ESC) alarm limits
- ↳ Press P to confirm the set value
- ↳ Leave the user menu by pressing 0 several times until the cabinet temperature is shown in the display



‘Set alarm’ is fixed, operating independently from the setpoint. The alarm limits will remain the selected values regardless of the setpoint being altered.

‘Escorted alarm’ is fixed and locked to the setpoint. The alarm limits will change according to the altered setpoint.



- ATTENTION -

High and low temperature alarms set up in the cabinet’s controller (including EAL alarms) must be accompanied by additional redundant independent external alarms to ensure maximum item safety.

Display sensor

The following part covers the setting of which sensor to be shown in the display.

O-18*: dPS – Selection of reference sensor for the display

- ↳ Press and hold $\text{P} + \text{1}$ for more than 3 seconds
- ↳ Press + several times until “dPS” is shown in the display
- ↳ Press P to select “dPS”
- ↳ Press + or - to select either the A- or E-sensor
- ↳ Press P to confirm the set value
- ↳ Leave the user menu by pressing ⏻ several times until the cabinet temperature is shown in the display



The dPS only changes the reference sensor for the display, and not the reference sensor for the alarms.



The reference sensor for the refrigeration system is the A-sensor, this cannot be altered.



- ATTENTION -

High and low temperature alarms set up in the cabinet's controller (including EAL alarms) must be accompanied by additional redundant independent external alarms to ensure maximum item safety.

Cleaning

Inadequate cleaning can lead to the cabinet not functioning properly or at all.



The cabinet must be completely thawed prior to cleaning.

The cabinet should be cleaned internally with a mild soap solution (max. 85 °C) at suitable intervals and checked thoroughly before it is put into operation again.

Cleaning agents with a pH of 5 ± 1 can be used if a mild soap solution or water is used to remove any substance that might damage cabinet components or surfaces. The cleaning agent should be compatible with materials such as steel, alloy, sheet metal, paint, and plastics.

The compressor compartment and in particular the condenser must be kept free from dust and dirt. This can be done with a vacuum cleaner and a brush.

Cleaning agents containing chlorine (or chlorine compounds), abrasive or solvent compounds as well as other corrosive agents, may not be used, as they might damage the cabinet and its components.

The location of the condenser is illustrated below.



Door gasket

The following part covers the importance of a properly functioning door gasket.

Door gaskets are an important part of the cabinet, door gaskets with impaired functionality reduces a cabinets seal with the door. Impaired seals can lead to ice build-up (thus reduced cooling capacity), and in some cases, decreased lifetime expectancy of the cabinet.

It is therefore very important to be aware of the door gasket's condition. Regular inspection is recommended.

The door gasket should be cleaned regularly with a mild soap solution and dried off with a dry cloth.

If a gasket needs to be replaced, please contact your local Gram BioLine distributor.

The illustration below shows the location of the gaskets.

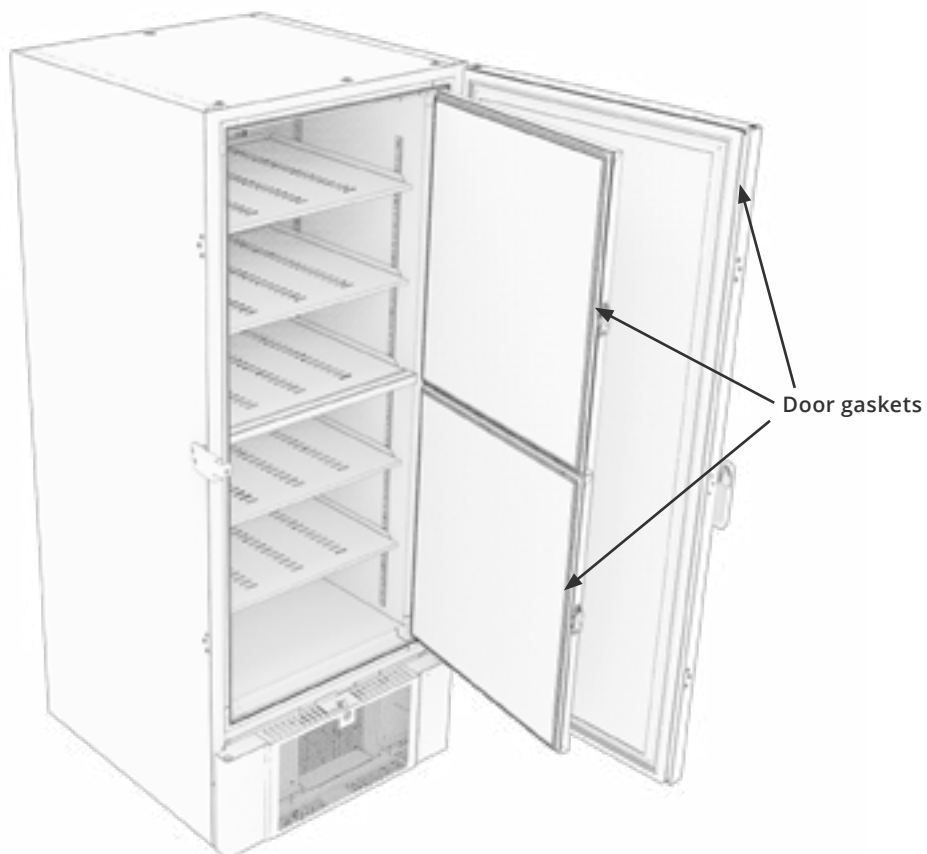

Defrosting the inner doors and cabinet

The following part covers the procedure for manually defrosting inner doors and cabinet.



The BioUltra has no automatic defrosting system and requires manual defrosting.

In the event of excessive frost and ice build-up, where it hinders performance, general use, and/or item safety, defrosting the chamber and inner doors is needed.

Please, follow the procedure described below to clean the chamber and inner doors of ice build-up:

- ↳ (If applicable) Turn off the back-up system
- ↳ Transfer the stored items to an appropriate environment
- ↳ Turn off the cabinet
- ↳ Open the inner doors more than 90°
- ↳ Lift off the inner doors and either let the ice thaw or manually defrost them
- ↳ Let the freezer defrost by thawing (with doors open). Thawing agents such as hot water must not be used.
- ↳ Collect the accumulated water in the bottom of the chamber
- ↳ After cleaning the inner doors and chamber, mount the inner doors to the cabinet
- ↳ Turn on the cabinet, according to the procedures in "Start-up"
- ↳ Put the items back in the chamber when the temperature has stabilised at the desired temperature
- ↳ (If applicable) Turn on the back-up system

Use the ice scraper included with the cabinet for any manual defrosting, do not hack or chip at the ice.



If necessary, it is possible to defrost the inner doors periodically without taking the cabinet out of service. Unmount the inner doors according to the instructions on this page, and defrost manually or by thawing. Ensure that the outer door is closed while the inner doors are being defrosted.

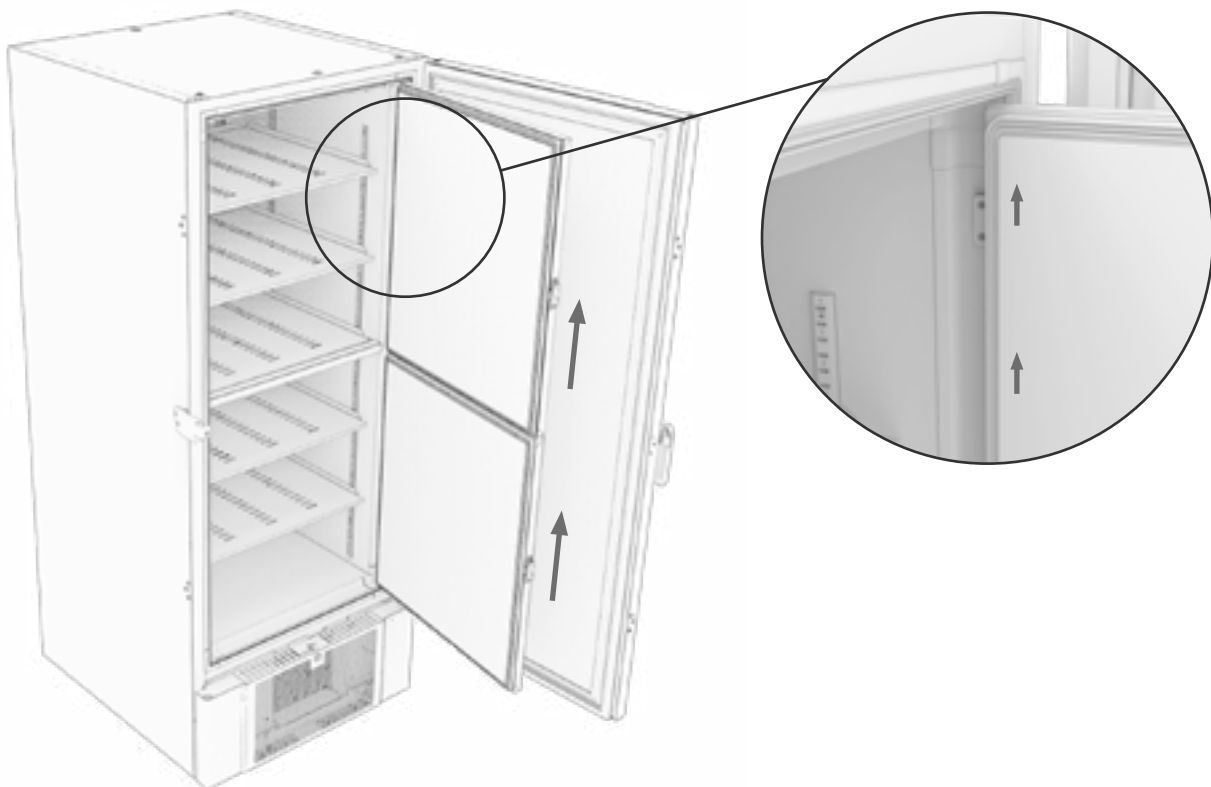

Equalisation valve

The equalisation valve may require cleaning depending on use and ambient conditions.

Over the duration of over time, a small amount of ice can form around the inside of the pressure equalisation valve. If allowed to build up, pressure equalisation will be impeded to the point where the cabinet is not able to equalise through the valve after a door opening. This in turn forces the equalisation to occur over the door gaskets. Thereby potentially damaging gasket, creating unwanted ice formations around the door and exceedingly long equalisations.

Routinely make sure that the equalisation valve and the port leading into the storage chamber is free of ice and is in proper working order.

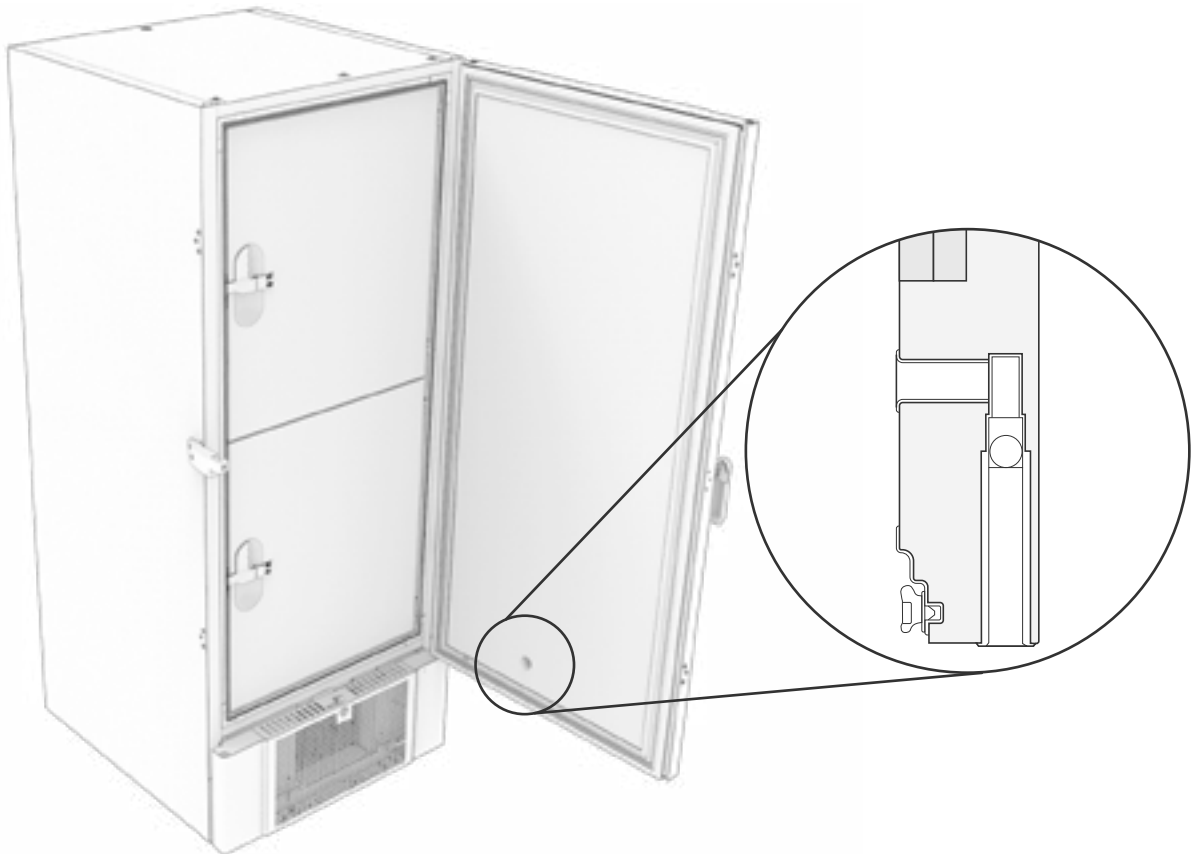

The illustration above shows the location of the equalisation valve.

Responsibility

Read the following carefully, for information on technical safety and responsibility on Gram BioLine products.



- WARNING -

DO NOT OPEN, MAINTAIN OR SERVICE IN AN AREA WHEN AN EXPLOSIVE ATMOSPHERE IS PRESENT



- When servicing -

Make sure the appliance is switched off at the socket before service is performed on the cabinet.
It is not sufficient to switch the cabinet to standby the cabinet on the On/Standby  key, as current will persist in some electrical parts of the cabinet.



Warranty may be void in the instance the cabinet is being used for applications other than its intended use, or otherwise not in accordance with the guidelines stipulated in the instructions for use.



Defective parts must be replaced with original parts from Gram BioLine. Gram BioLine can only guarantee functional and safety requirements on the cabinets, if above mentioned is adhered to.



The cabinet should be checked at least once yearly by a Gram BioLine-authorized technician. The refrigeration system and the hermetically sealed compressor require no maintenance. However the condenser requires regular cleaning.



Be aware that cabinets using hydrocarbons (HC) as refrigerant, may require special handling by qualified technicians.

Type/number plate

If refrigeration fails, first look to see whether the cabinet has been unintentionally switched off, or whether a fuse has blown.

If the cause of failure cannot be found, contact your supplier quoting type and S/N. This information can be found on the type/number-plate.



Access port

All BioLine cabinets are equipped with an access port on the back of the cabinets, this can be used to easily fit external sensors and the like.

The illustration below shows an access port on a BioUltra cabinet.

The access ports are constructed in the same fashion, with two conical polystyrene plugs (fitted from the back of the cabinet and the inside of the cabinet).

Please note: It is very important to ensure that the access port is sealed properly prior to start-up after mounting sensor, probe etc. Failing to do so can result in lowered performance or malfunction of the cabinet.

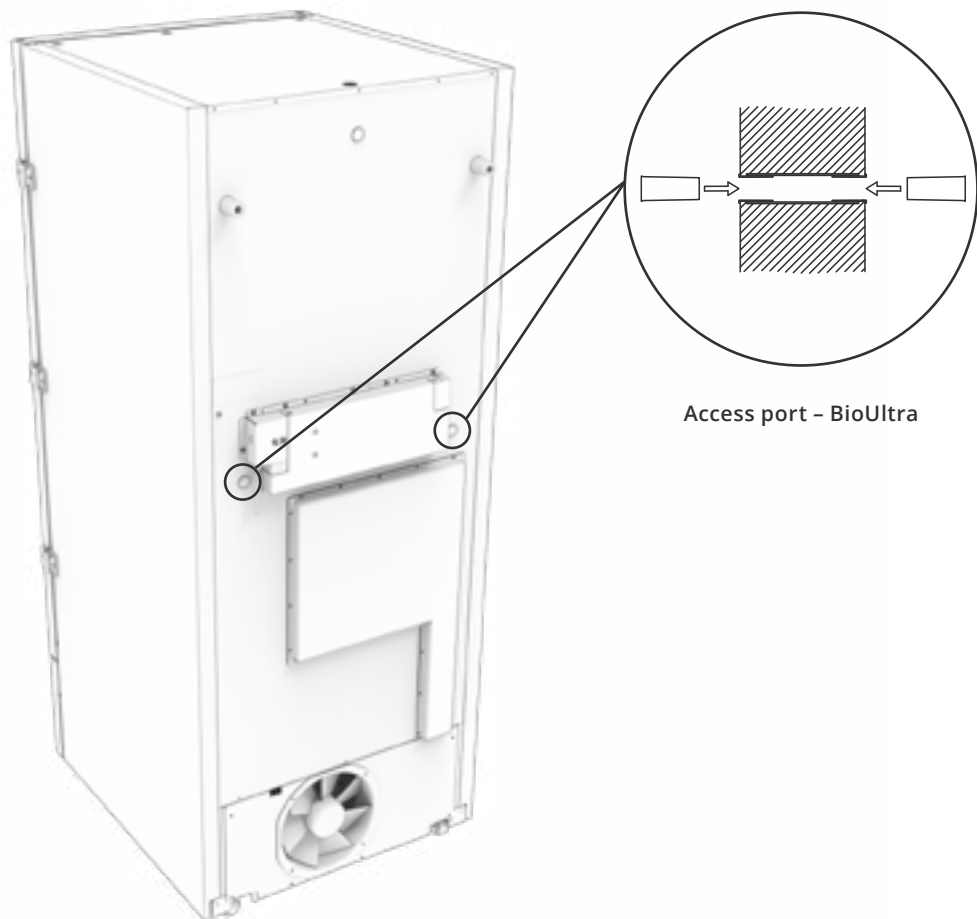

Door lock

The BioUltra cabinet is equipped with a safety lock.

The illustrations below shows the safety lock.

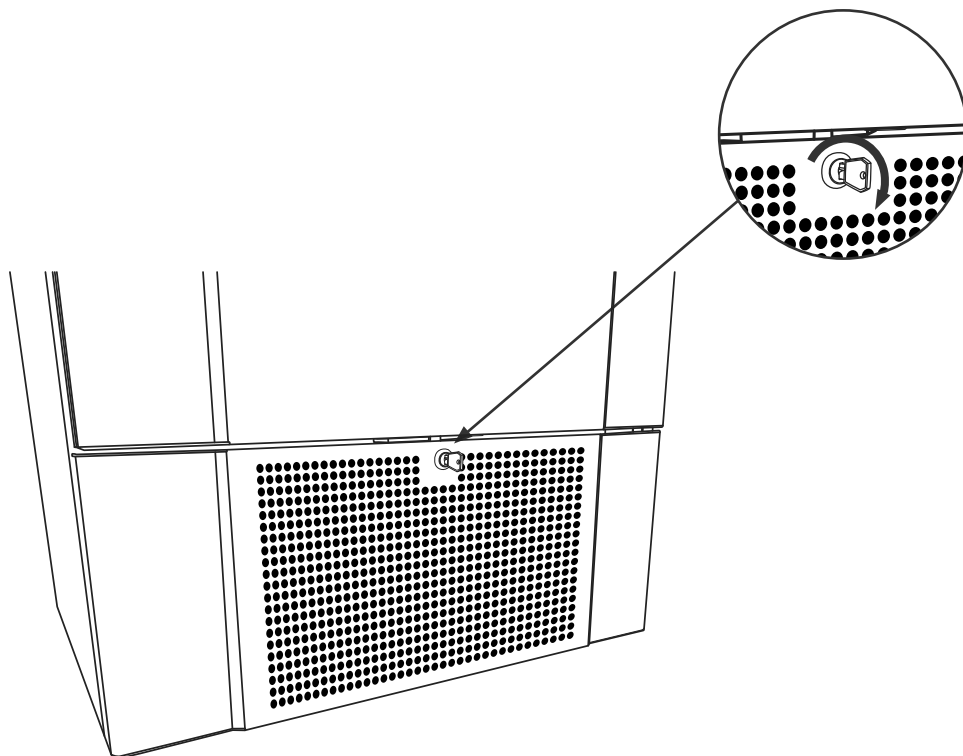

Boxes and racks

This part covers quantity of racks stored in the cabinet.

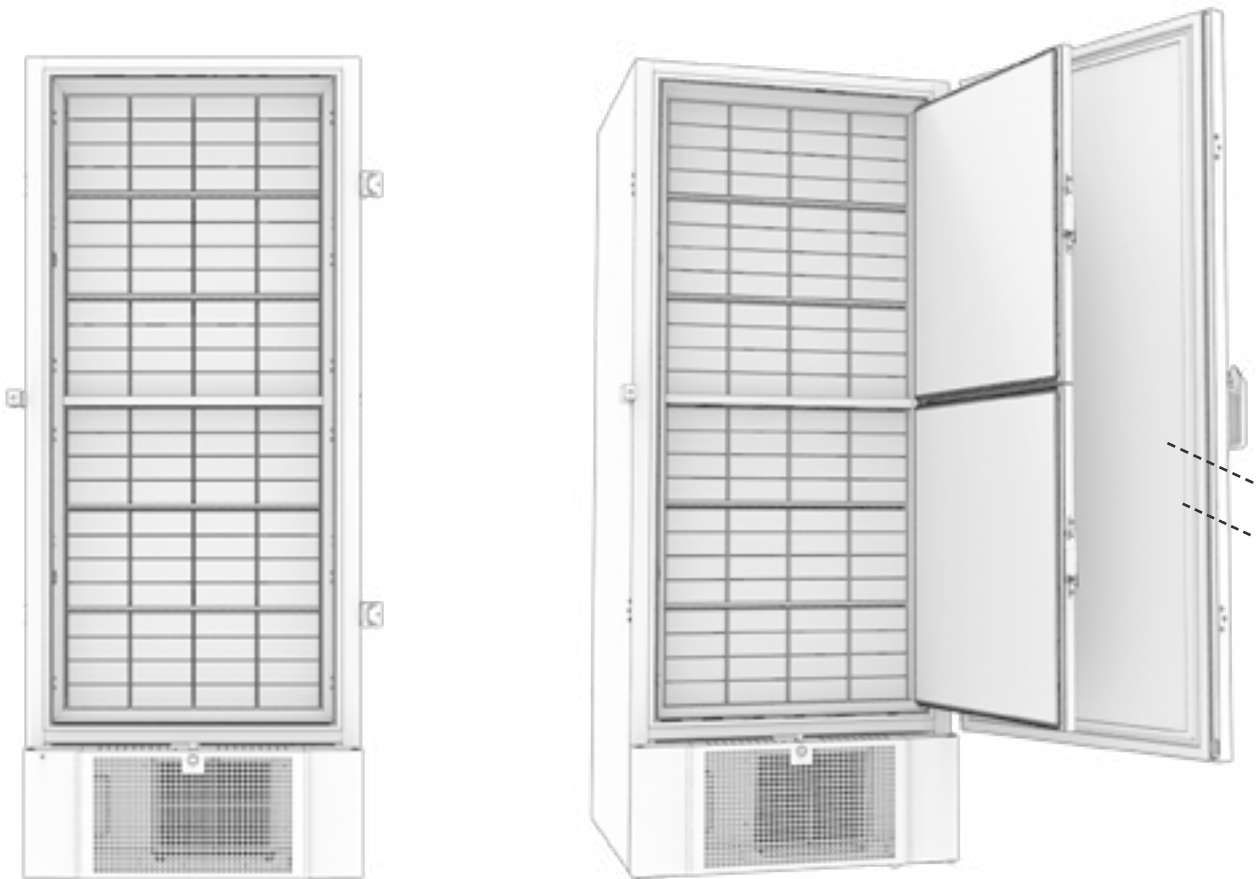

Box size	Number of boxes	Number of racks
2"/50 mm	384	24 (4 x 4 racks)
3"/75 mm	192	16 (3 x 4 racks)
4"/100 mm	192	24 (2 x 4 racks)

Mount/unmount door handle

The door handle can easily be unmounted and mounted again.

In the case of the handle needing to be taken off, make sure that it is mounted back onto the cabinet prior to starting up again.

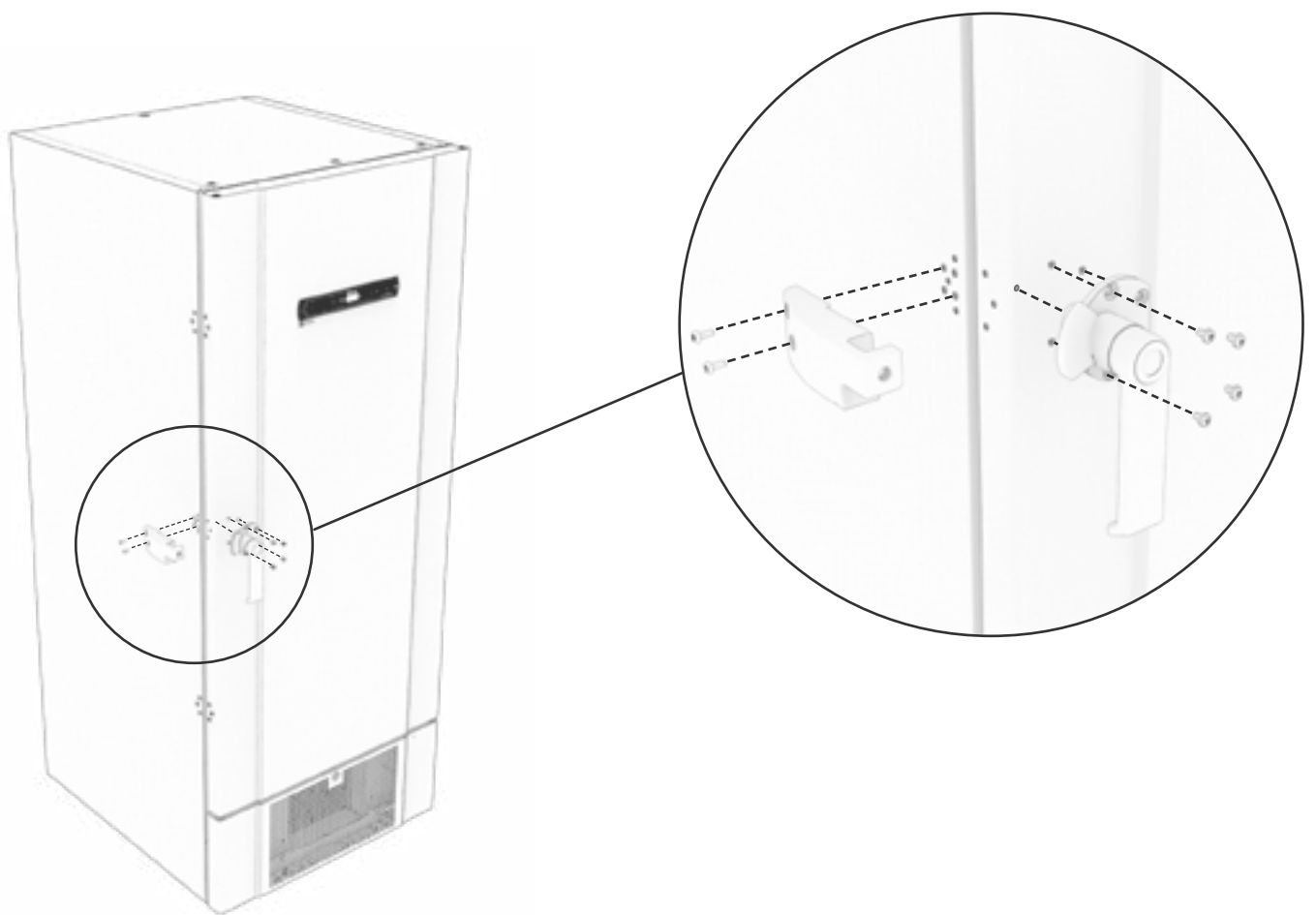

- ATTENTION -

The cabinet must not operate without door handle.

Important



– IMPORTANT –

1. There may occur sharp edges on the cabinet housing, compressor room, and interior furnishings. Show due diligence when handling the cabinet, negligence of these precautions can lead to injuries.
2. Be cautious about the potential risk of body parts getting wedged in the frame slot between the door and the cabinet when opening or closing the cabinet. Exercise due diligence to avoid any accidents. Failure to take these precautions may result in injuries.
3. Castors where the legs are not deployed can lead to unexpected movements of the cabinet. Lock the castors after installation. Negligence of these precautions can lead to injuries.
4. When the cabinet is positioned, ensure that at least two of the legs of the cabinet are deployed.
5. The fan may cause injury during operation, avoiding touching the fans while the cabinet is connected to the mains. Negligence of these precautions can lead to injuries.
6. Thawing agents such as hot water must not be used when thawing the cabinet.
7. Cabinets with water cooling must not leak.
8. No unauthorised modifications are allowed.

Disposal

This part describes the disposal of electrical and electronic equipment.

At Gram BioLine we are dedicated to environmental sustainability and comply fully with the Waste Electrical and Electronic Equipment (WEEE) Directive.

Electrical and electronic equipment (EEE) contains materials, components and substances that can be dangerous and harmful to human health and the environment if the waste (WEEE) is not disposed of correctly. When disposing the appliance in an EU Member State, it should be in accordance with the Waste Electrical and Electronic Equipment Regulations (WEEE).

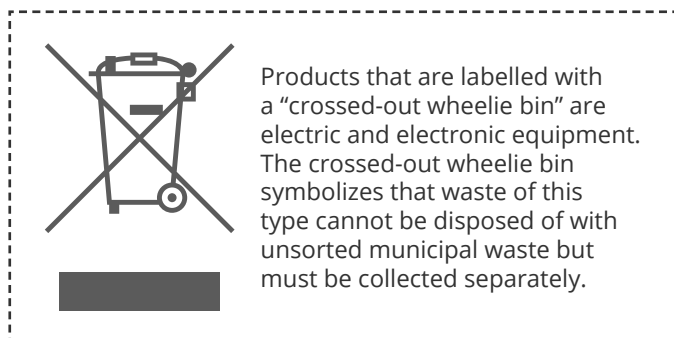

This refrigerator or freezer is specifically designed for bioscience purposes, it is therefore important to thoroughly clean the appliance to ensure that no residues or harmful substances remain. While it is not a requirement under the (WEEE) Directive to document the cleaning, it is considered good practice to ensure the refrigerator is free of contamination before it is sent for recycling or disposal. This helps protect individuals responsible for handling the appliance and ensures a safe and environmentally friendly recycling process.

Correct disposal and recycling of electrical and electronic equipment help reduce waste and minimize environmental impact. By adhering to proper handling practices, your organization supports pollution prevention and resource conservation. Recycled materials are sorted, cleaned, and processed for reuse, contributing to sustainability and reducing the need for new raw materials.

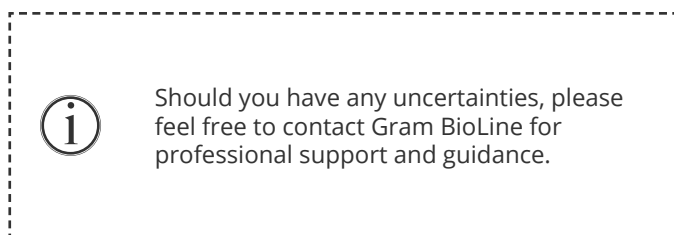

BioUltra UL570

General data: BioUltra UL570

Technical specifications	Data
Ambient temperature range	+10/+30 °C
Temperature range	-86/-60 °C
Control Unit	Gram BioLine MPC-46
Alarms	Acoustic and visual temperature alarm
Alarm ports	Voltage-free contact (230 VAC/8A)
Access port	2 pcs. Ø24 mm
Gross volume	570 litres
Door	Right or left hinged
Material interior	White lacquered steel, inside of doors and bottom panel in stainless steel 4016
Materiale exterior	White lacquered steel or stainless steel
Wall thickness	70 mm in sides 90 mm in back
Door thickness - Solid door	115 mm
Insulation	Polyurethane foam and vacuum panels
K-Value	0.2079 W/(m ² *K)
Dimensions: W x D x H	856 x 979 x 1986/1996 mm
Defrost system	Manuel defrost
IP class	IP21
ATEX certifikate	ExVeritas 26ATEX2340X
ATEX Marking	II 3G Ex ec nC ic IIB T4 Gc

BioUltra UL570 H, 50 Hz

Technical specifications	Data
Refrigerant	R404A/R508B/R601
Refrigerant charge	215/300/30 g
GWP - CO2e	R404A/R508b=844/4019
Connection	230 VAC/50 Hz (8A)
SW variant	E7+
Refrigeration capacity at -90 °C	497 Watt
Energy consumption -80/20*	12.2 kWh/24h
Energy consumption -80/25*	13.1 kWh/24h
Energy consumption - lowest setpoint	19.1 kWh/24h
Heat emission 100%	979 Watt
Heat emission default setpoint	798 Watt
Nominal consumption	1194 Watt/6.3 A
Start current	25.7 A
Gross weight	283 kg
Net weight	257 kg
Sound level	49 dB(A)

*) : Setpoint temperature/ambient temperature

BioUltra UL570 H, 60 Hz

Technical specifications	Data
Refrigerant	R404A/R508B/R601
Refrigerant charge	425/304/30 g
GWP - CO2e	R404A/R508b=1668/4072
Connection	230 VAC/60 Hz (8A)
SW variant	E8+
Refrigeration capacity at -90 °C	497 Watt
Energy consumption -80/20*	12.2 kWh/24h
Energy consumption - lowest setpoint	17.5 kWh/24h
Heat emission 100%	-
Heat emission default setpoint	-
Nominal consumption	1011 Watt/5.4 A
Start current	25.7 A
Gross weight	240 kg
Net weight	220 kg
Sound level	48.8 dB(A)

*) : Setpoint temperature/ambient temperature



BioUltra UL570 G, 50 Hz

Technical specifications	Data
Refrigerant	R290/R170/R601
Refrigerant charge	200/105/14 g
GWP – CO2e	0.66/0.48
Connection	230 VAC/50 Hz (16A)
SW variant	E8+
Refrigeration capacity at -90 °C	497 Watt
Energy consumption -80/20*	11.75 kWh/24h
Energy consumption – lowest setpoint	16.8 kWh/24h
Heat emission 100%	912 Watt
Heat emission default setpoint	725 Watt
Nominal consumption	1008 Watt/5.9 A
Start current	25.7 A
Gross weight	240 kg
Net weight	220 kg
Sound level	45.6 dB(A)

*) : Setpoint temperature/ambient temperature

BioUltra UL570 G, 50 Hz – hybrid

Technical specifications	Data
Refrigerant	R290/R170/R601
Refrigerant charge	275/105/14 g
GWP – CO2e	0.90/0.48
Connection	230 VAC/50 Hz (16A)
SW variant	E8+
Refrigeration capacity at -90 °C	497 Watt
Energy consumption -80/20*	10.5 kWh/24h
Energy consumption – lowest setpoint	16.2 kWh/24h
Heat emission 100%	833 Watt
Heat emission default setpoint	676 Watt
Nominal consumption	1008 Watt/5.9 A
Start current	25.7 A
Gross weight	240 kg
Net weight	220 kg
Sound level	-
Water connection	½" inlet and outlet
Water consumption setpoint -90 °C	120l/h
Energy transferred to water	75% of power consumption

*) : Setpoint temperature/ambient temperature

BioUltra UL570 H, 50 Hz – hybrid

Technical specifications	Data
Refrigerant	R404A/R508B/R601
Refrigerant charge	535/300/30 g
GWP – CO2e	N/A
Connection	230 VAC/50 Hz (16A)
SW variant	E8+
Refrigeration capacity at -90°C	497 Watt
Energy consumption -80/20*	12.2 kWh/24h
Energy consumption – lowest setpoint	19.1 kWh/24h
Heat emission 100%	980 Watt (with no water cooling)
Heat emission default setpoint	798 Watt (with no water cooling)
Nominal consumption	1191 Watt/6.3 A
Start current	25.7 A
Gross weight	240 kg
Net weight	220 kg
Sound level	–
Water connection	½" inlet and outlet
Water consumption setpoint -90°C	120l/h
Energy transferred to water	75% of power consumption

*): Setpoint temperature/ambient temperature

BioUltra UL570 H, air cooled, 50 Hz

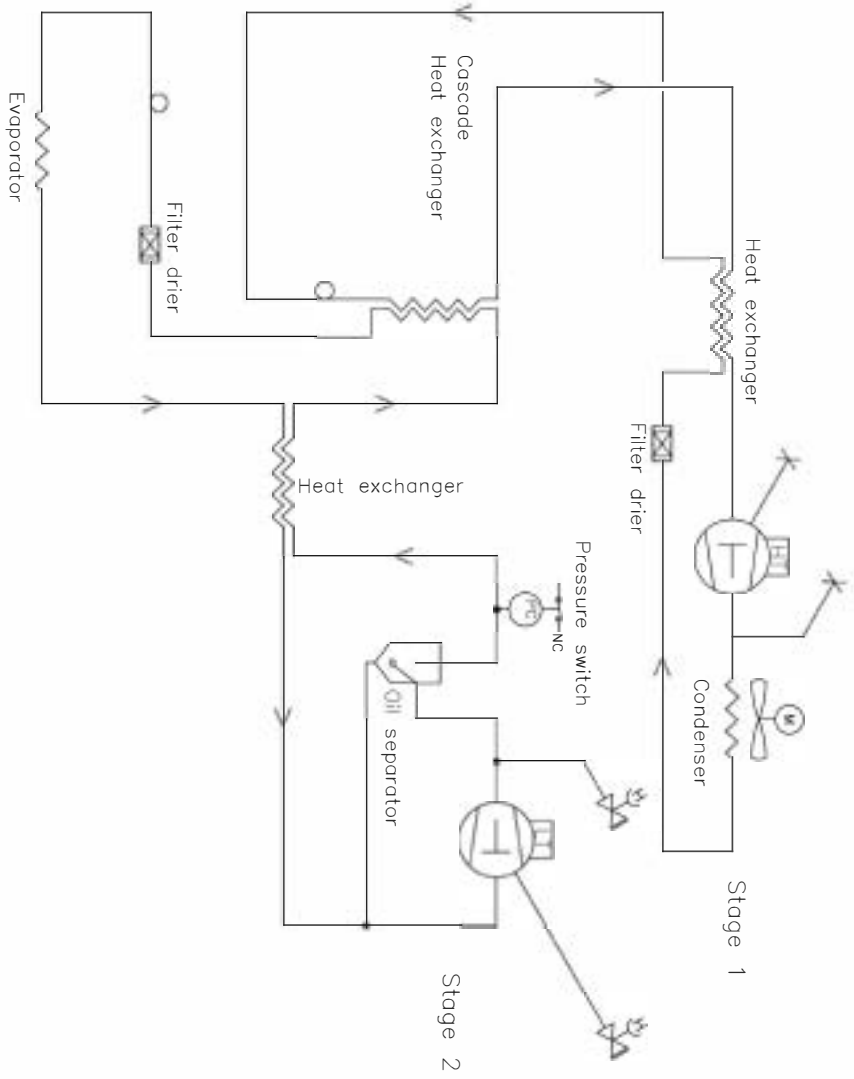

Revision				Inspection / important Dimension marked with (XXX)	
Description: Piping diagram BioUltra HFC, air cooled, 50Hz				General tolerances: ISO 2768-m; ISO 286-2	
Gram Scientific Aps VOLENS DENMARK		Date 03-01-2023	Sign. JMB	Sheet size 3	Drawing no. 765041577
All rights to this drawing belong to Gram Scientific A/S or its legal Copyright. Thus the drawing should not be used without our written permission or be copied, presented or passed over to a third person. Misuse will lead to prosecution.				Sheet no. 1 of 1	Rev. 005

BioUltra UL570 H, air cooled, 60 Hz

BioUltra UL570 G, air cooled, 50/60 Hz

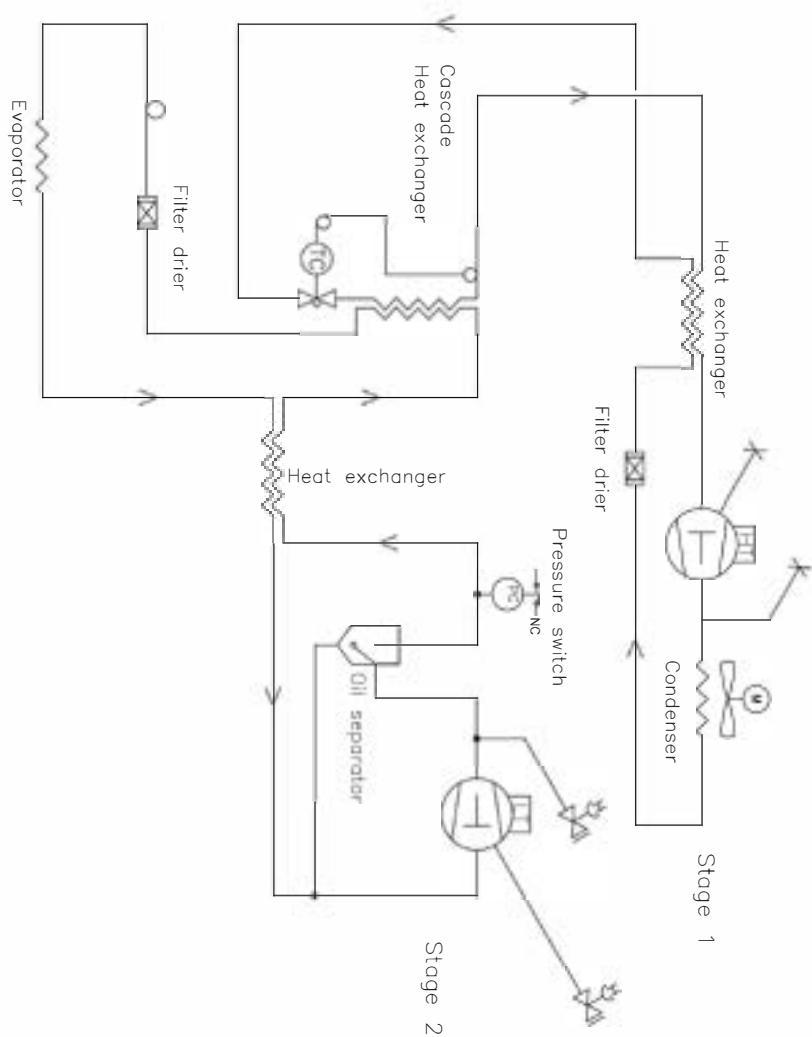

Revision		Inspection / important Dimension marked with (XXX)	
Description Piping diagram BioUltra HFC 60Hz		General Tolerances: ISO 2768-m; ISO 286-2	
Gram Scientific Aps VOJENS DENMARK	Date 03-01-2023	Sign. JMBP	Sheet no. 3
Drawing no. 765042326		Sheet no. 1 of 1	Rev. 001

All rights in this drawing belong to Gram Scientific Aps. All rights of Copyright. Thus, this drawing should not without our written permission be copied, presented or passed over to a third person. Misuse will lead to prosecution.

BioUltra UL570 H, hybrid (air and water cooled)

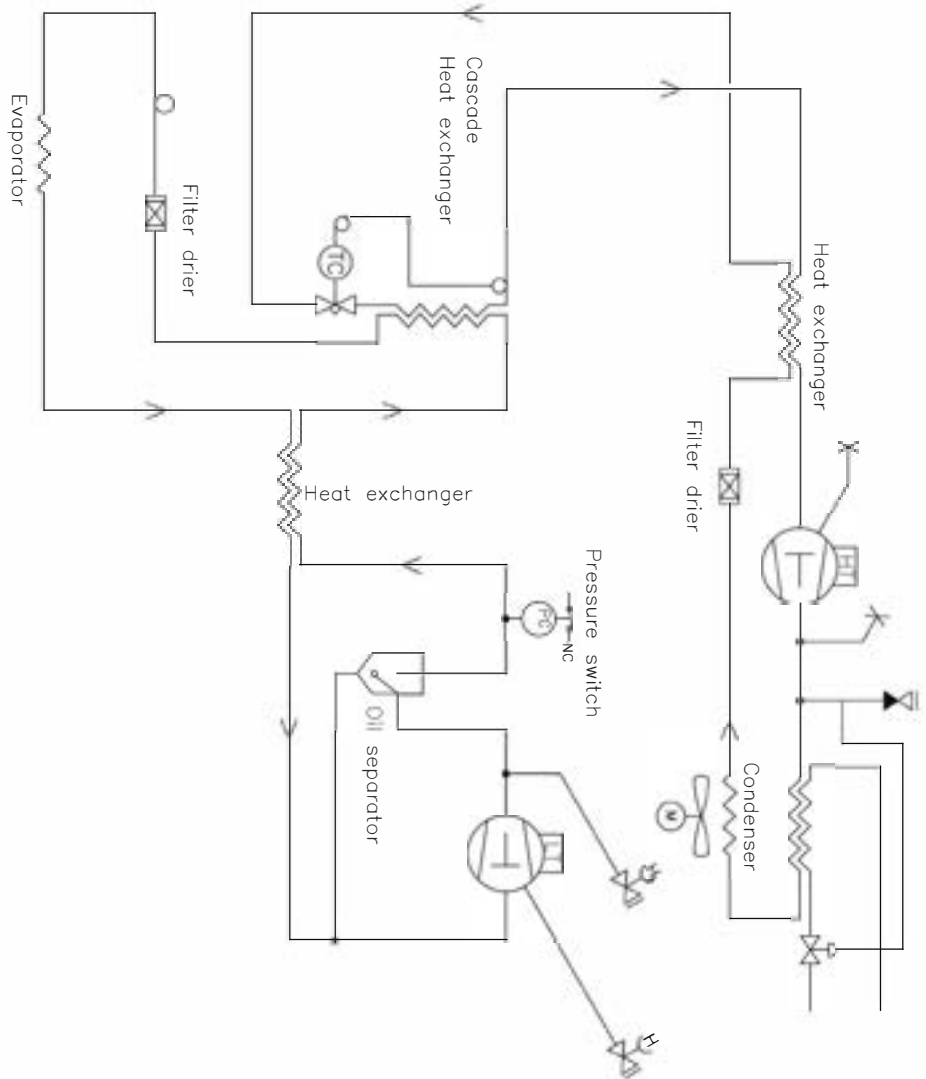

Revision		Inspection / important Dimension marked with (XXX)	
Description: Piping diagram BioUltra HFC hybrid		General tolerance: ISO 2768-m : ISO 286-2	
Gram Scientific Aps DENMARK	Date 03-01-2023	Sign. MBP	Sheet size 3
Drawing no. 765042325		Sheet no. 1 of 1	Rev. 000

All rights to the drawing belongs to Gram Scientific Aps. All law of Copyright. This drawing should not be reproduced or written permission to copy, present or passed on to a third person, unless all said to production.

BioUltra UL570 G, air cooled

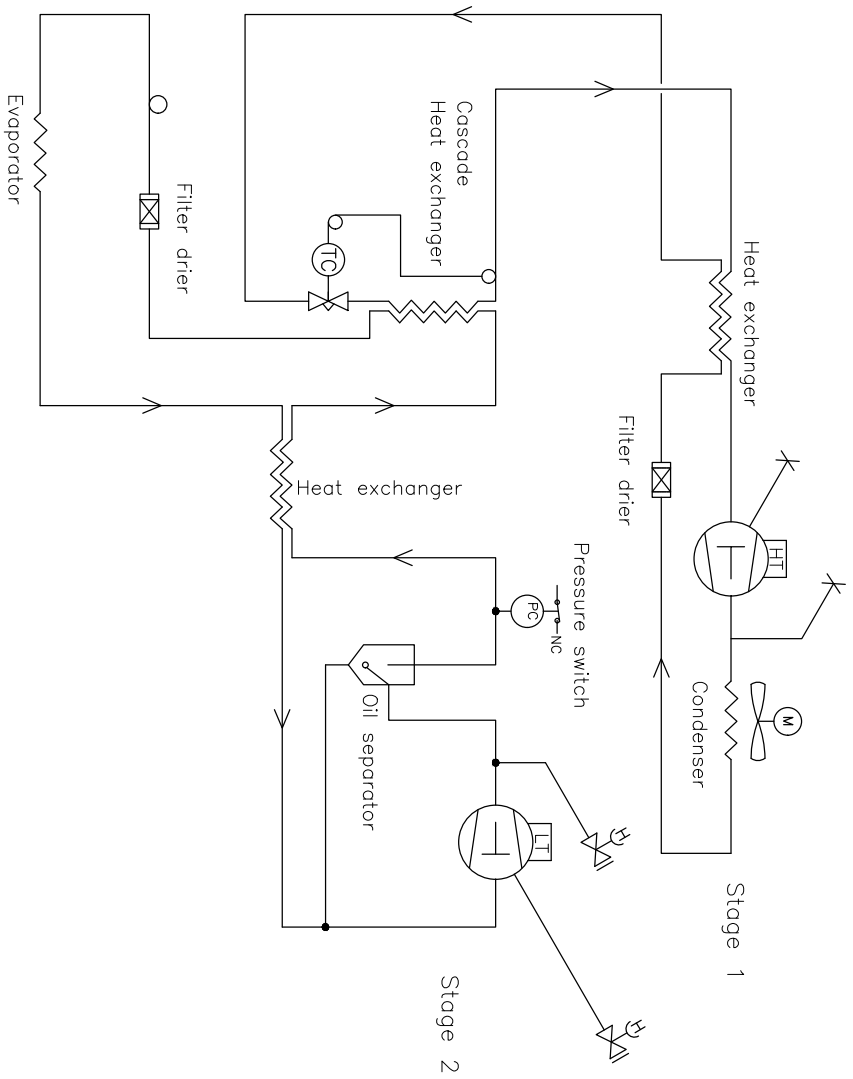

Revision		Inspection / Important Dimension marked with (XXX)	
Description: Piping diagram BioUltra HC w/TX valve		General tolerance: ISO 2768-m : ISO 286-2	
Gram Scientific ApS (CVR-nr: 43122193) Aage Grams Vej 1 6900 Vejens	Date 03-01-2023	Sign. JHP	Sheet size 3
Drawing no. 765042497		Sheet no. 1 of 1	Rev. 000
<small>All rights in this drawing belong to Gram Scientific ApS, of law of Copyright. Thus the drawing should not be used without our written permission in special permission of patent claims in this drawing. Written on file in P. Svedholm.</small>			

BioUltra UL570 G, hybrid (air and water cooled)

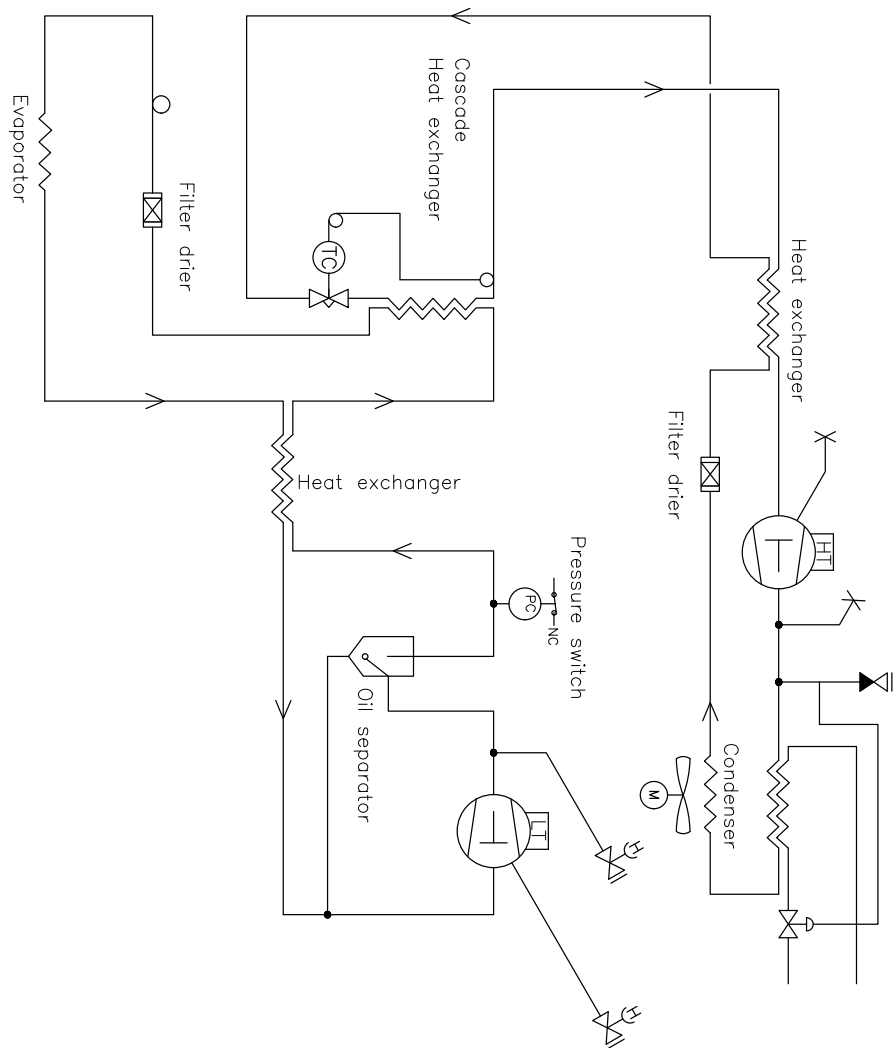

Revision		Description:		Inspection / Important Dimension marked with	
Piping diagram BioUltra HC hybrid		Gram Scientific APS (CV-Rev: 43122193) Aage Grams Vej 1 6500 Vojens		XXX	
Date	Sign.	Sheet size	Drawing no.		
03-01-2023	JJBP	3	765042498		
All rights to this drawing belong to Gram Scientific APS. If law of Copyright, Thus the drawing should not without our written permission be copied, presented or passed over to a third person. Misuse will lead to prosecution.			Sheet no.	1	of 1
			Rev.	000	

Wiring diagram

BioUltra UL570

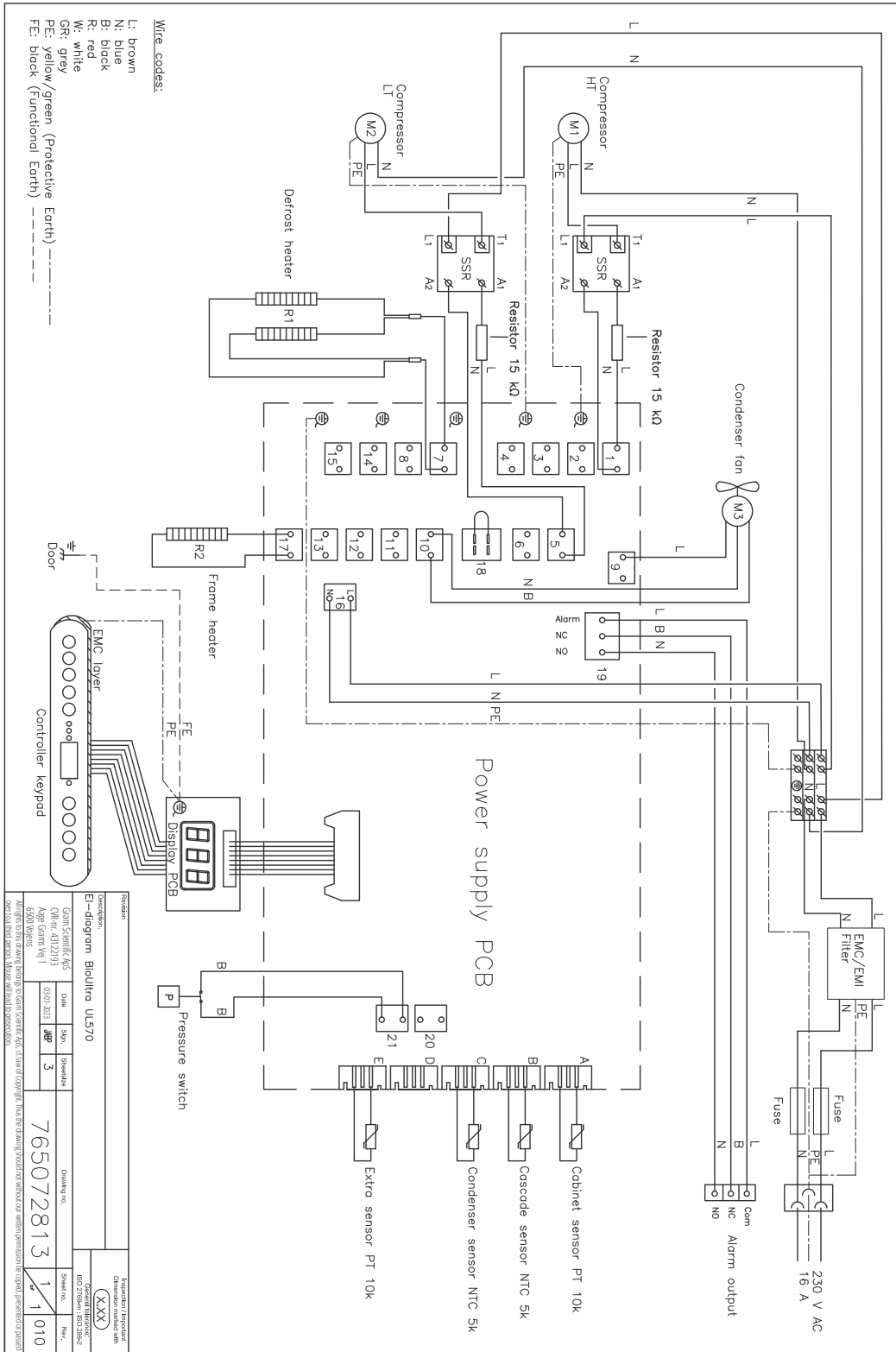

BioUltra UL570



English EC Declaration of Conformity

We, **Gram Scientific ApS**, declare as manufacturer under sole responsibility that the following products comply with all relevant regulations:

Range:	BioUltra
Model:	UL570
Refrigerant:	HC: R290 & R170 (R601 as additive) HFC: R404A & R508B (R601 as additive)
Product description:	Extreme low temperature freezers for storing biomedical materials
Valid from (Year/Week):	2023/01

This declaration pertains to compliance with all applicable essential requirements and other provisions of the European Council Directive and regulations. Specifically, the following Directives and Regulations of the European Parliament and of the Council apply:

Directives and Regulations of the European Parliament and of the Council:

- Machinery Directive 2006/42/EC
- ATEX Directive 2014/34/EU
- Pressure Equipment Directive 2014/68/EU
- Low Voltage Directive 2014/35/EU
- EMC Directive 2014/30/EU
- RoHS Directive 2011/65/EU
- REACH EC No. 1907/2006
- F-Gas Regulation (EU) No 2024/573

Product compliance has been demonstrated based on the following harmonized standards:

Harmonized Standards:	Text:
EN 60601-1:2006	Medical electrical equipment – Part 1: General requirements for basic safety and essential performance
EN 60601-1-2:2015	Medical electrical equipment – Part 1-2: General requirements for basic safety and essential performance – Collateral Standard: Electromagnetic disturbances – Requirements and tests
EN 61010-1:2010	Safety requirements for electrical equipment for measurement, control, and laboratory use - Part 1: General requirements
EN 61326-1:2013	Electrical equipment for measurement, control and laboratory use – EMC requirements – Part 1: General requirements
EN IEC 61000-3-2:2019	Electromagnetic compatibility (EMC) – Part 3-2: Limits – Limits for harmonic current emissions (equipment input current ≤ 16 A per phase)
EN 61000-3-3:2013	Electromagnetic compatibility (EMC) – Part 3-3: Limits – Limitation of voltage changes, voltage fluctuations and flicker in public low-voltage supply systems, for equipment with rated current ≤ 16 A per phase and not subject to conditional connection
EN IEC 60079-0:2018 EN IEC 60079-0:2018/AC:2020	Explosive atmospheres – Part 0: Equipment – General requirements
EN 60079-7:2015 EN 60079-7:2015/A1:2018	Explosive atmospheres – Part 7: Equipment protection by increased safety "e"
EN 60079-11:2012	Explosive atmospheres – Part 11: Equipment protection by intrinsic safety "i"
EN IEC 60079-15:2019	Explosive atmospheres – Part 15: Equipment protection by type of protection "n"
EN 60079-18:2015	Explosive atmospheres – Part 18: Equipment protection by encapsulation "m"
EN ISO 3744:2010	Acoustics – Determination of sound power levels and sound energy levels of noise sources using sound pressure – Engineering methods for an essentially free field over a reflecting plane
EN ISO 9001:2015	Quality management systems – Requirements
EN ISO 14001:2015	Environmental management systems – Requirements with guidance for use

Gram Scientific ApS
 Aage Grams Vej 1
 DK-6500 Vojens
 Denmark
 Telephone: + 45 73 20 13 00

Vojens, 20.03.2024



John B. S. Petersen
 Approval Manager

Rev. 009 – 20.03.2024

General maintenance information

- Implement a cleaning routine.
- Cleaning tasks should be documented and kept record of.
- Check the temperature of your refrigerator/freezer regularly.
- When storing valuable or temperature-sensitive materials or products, it is advisable to employ a continuously monitoring autonomous alarm system. This alarm system should be designed in a manner that allows authorised individuals to promptly detect each alarm state and take the necessary corrective actions.

- WARNING -



- Maintenance work should only be performed by a Gram BioLine authorised technician.
- Make sure that the refrigerator/freezer is switched off at the socket before any maintenance work is performed.
- Transfer all contents to another refrigerator or freezer under safe and regulated conditions.

Maintenance plan

The following maintenance plan represents a generic schedule for maintenance. Use and/or conditions may impact the required frequency of the subsequent points.

Component	Task	Frequency
Base	<ul style="list-style-type: none"> Ensure cabinets with legs are levelled properly and cabinets with castors are placed on a level surface and locked. 	Yearly
Interior fittings	<ul style="list-style-type: none"> Ensure that all interior fittings are fixed correctly. 	Yearly
Door gasket	<ul style="list-style-type: none"> Ensure that the gasket is pliable and in good working order. Ensure that the door is aligned with the door frame and fits tightly when closed. 	Yearly
Condenser and fan	<ul style="list-style-type: none"> Ensure it is not dented or shows any other signs of damage and does not make any abnormal noises. 	Yearly
Keypad	<ul style="list-style-type: none"> Ensure it is not dented or shows any other signs of damage. 	Yearly
Ice build-up	<ul style="list-style-type: none"> Ensure ice accumulation does not hinder operation or performance. 	Monthly
Power cord	<ul style="list-style-type: none"> Ensure correct fitment. 	Yearly
Compressor compartment	<ul style="list-style-type: none"> Ensure that the compressor compartment is kept free of dust or other contaminants. 	Yearly
Re-evaporation tray	<ul style="list-style-type: none"> Ensure it is not cracked or shows any other signs of damage. 	Yearly
Access port	<ul style="list-style-type: none"> Ensure that the access port is sealed properly and check for moisture ingress. 	Yearly
Defrost water tube (if applicable)	<ul style="list-style-type: none"> Inspect for damage and obstructions. 	Yearly
Door switch (if applicable)	<ul style="list-style-type: none"> Ensure proper functionality to guarantee the fan in the cabinet stops, the interior lighting turns on if present, and the display shows "-0-". 	Yearly
Door alarm test	<ul style="list-style-type: none"> Ensure it activates when the door is left open. 	Yearly
Temperature	<ul style="list-style-type: none"> Ensure the appliance consistently maintains correct storage conditions. When storing valuable or temperature sensitive materials or products, it is advisable to employ a continuously monitoring autonomous alarm system. This alarm system should be designed in a manner that allows authorised individuals to promptly detect each alarm state and take the necessary corrective actions. 	Yearly

Component	Task	Frequency
High and low temperature alarms	<ul style="list-style-type: none"> • Ensure that the temperature alarms are set and work accordingly. • When storing valuable or temperature sensitive materials or products, it is advisable to employ a continuously monitoring autonomous alarm system. This alarm system should be designed in a manner that allows authorised individuals to promptly detect each alarm state and take the necessary corrective actions. 	Yearly
Door hinges	<ul style="list-style-type: none"> • Check for wear and ensure proper function. 	Yearly
Door self-closing mechanism	<ul style="list-style-type: none"> • Ensure that the door automatically closes when opened $< 90^\circ$. • Ensure that the door stays/do not close when opened $> 90^\circ$. 	Yearly
Door handle (if applicable)	<ul style="list-style-type: none"> • Ensure secure attachment and correct engagement. 	Yearly
Chart recorder (if applicable)	<ul style="list-style-type: none"> • Ensure that it accurately records and stores temperature data. 	Yearly
Lock	<ul style="list-style-type: none"> • Ensure it operates smoothly. 	Yearly
Sensors	<ul style="list-style-type: none"> • Test sensors to ensure accurate readings and functionality. 	Yearly
Cleaning	<ul style="list-style-type: none"> • Refer to the cleaning section. 	

- SPARE PARTS -



If you require spare parts, please contact your local Gram BioLine distributor. Defective parts must be replaced with original parts from Gram BioLine. Gram BioLine can only guarantee functional and safety requirements on the cabinets, if above mentioned is adhered to.

- The refrigerator/freezer must be cleaned before taken into operation.
- We recommend cleaning the refrigerator/freezer regularly to ensure efficient operation.
- We recommend using pH-neutral all-purpose cleaners and soft cleaning cloths.
- If any detergent or cleaning agent are used to clean the refrigerator/freezer, ensure that the refrigerator/freezer is thoroughly rinsed with clean water and a clean cloth to remove any cleaning agent or detergent traces.
- Ensure that the refrigerator/freezer has been dried thoroughly with a clean cloth before taken into operation.

- WARNING -

Do not use the below disinfectants and cleaners:



- Do not use abrasive cleaners.
- Do not use harsh chemicals.
- Do not use solvents.
- Do not use acidic or alkaline cleaners nor any cleaning agents that contain chloride.

- WARNING -

Do not use the below tools in general:



- Do not use metal brushes.
- Do not use water jets.
- Do not use abrasive sponges or steel wool.
- Do not use any sharp tools.
- Do not use electrical heating or steam-cleaning appliances, flames, or defroster sprays to defrost.

- WARNING -

- Do not remove the type/number plate, located inside the refrigerator/freezer (refer to type/number plate section).
- Make sure no water gets close to any electrical components.
- Do not flush the compressor compartment and evaporator with water as this may cause short-circuits in the electrical system.



Cleaning plan

The following cleaning plan represents a generic schedule for cleaning. Use and/or conditions may impact the required frequency of the subsequent points.

Task	Minimum maintenance interval
Cleaning the air filters (if applicable)	Yearly
Cleaning the re-evaporation tray	Yearly
Cleaning the exterior	Half-yearly
Cleaning the interior	Half-yearly
Cleaning the shelves/drawers	Regularly
Cleaning the condenser and the compressor compartment	Yearly
Cleaning the door gasket	Regularly
Cleaning the defrost water tube (if applicable)	Yearly

Cleaning the air filters (if applicable)



- WARNING -

- The air filters should only be re-attached when completely dry.

Cleaning agents and tools

- pH-neutral all-purpose cleaners (optional).
- Soft cloth (optional).
- Bucket or similar (optional).

The air filters on the condenser and the front panel should be removed and cleaned with lukewarm water (max. 50° C). If the air filters are very dirty fill a bucket or similar with a mild solution of pH-neutral all-purpose cleaner. Submerge the air filters completely for approximately 10 minutes and rinse thoroughly with clean warm water. Let the air filter air-dry completely before reattaching them.

Cleaning the re-evaporation tray



- WARNING -

- Be careful not to damage the defrost water tube and the heating element (located in the tray) when cleaning.

Cleaning agents and tools

- Soft cloth.
- pH-neutral all-purpose cleaner.

It is recommended that the re-evaporation tray is checked regularly for foreign objects and cleaned with a pH-neutral all-purpose cleaner at least once a year. Rinse the tray thoroughly with clean warm water and remember to dry the re-evaporation tray completely.

Cleaning the interior and exterior



- WARNING -

- Do not use any tools or methods to speed up defrosting other than the ones specified in this instructions for use.
- Do not pour water directly into the unit.

Cleaning agents and tools

- pH-neutral all-purpose cleaners.
- Use a soft cloth to clean off dust or other contaminants from the refrigerator or freezer.

Manual defrost

Our conventional refrigerators/freezers feature automatic defrosts (see section for defrost) but the refrigerator/freezer should be manually defrosted prior to cleaning. Make sure all contents are stored elsewhere before defrosting.

Manual defrosting is done by switching off the refrigerator/freezer at the socket. Leave the door open for 24 hours and be cautious of excess water being spilled onto the floor. Be sure to keep the floor and the interior as dry as possible during the process by placing towels or similar onto the surfaces.

Remove all shelves and drawers and clean the cabinet (max. 85° C). Rinse the refrigerator/freezer thoroughly with clean warm water. Check and dry thoroughly before it is put into operation again.

Cleaning the shelves/drawers



- WARNING -

- Shelves/drawers shall be hand washed.
- Do not use excessive force when removing and inserting the shelves/drawers.

Cleaning agents and tools

- pH-neutral all-purpose cleaners.
- Soft cloth.

Remove all shelves/drawers from the refrigerator/freezer and wash them using a soft cloth. Rinse the shelves/drawers thoroughly with clean warm water. Check and dry thoroughly before it is put into operation again.

Cleaning the condenser and the compressor compartment



- WARNING -

- Ensure not to damage the condenser.
- Components in the compressor compartment may be hot.
- The refrigeration system and the hermetically sealed compressor require no maintenance.

Tools

- Use a brush, a soft cloth, or a vacuum cleaner.

The compressor compartment and in particular the condenser must be kept free from dust or other contaminants.

Cleaning the door gasket



- WARNING -

- Do not pour water directly into the unit.

Cleaning agents and tools

- pH-neutral all-purpose cleaners.
- Use a brush, a soft cloth, or a vacuum cleaner.

The door gasket should be cleaned regularly using a soft cloth. Dry the gasket completely with a clean cloth before taking the refrigerator/freezer into operation.

Cleaning the defrost water tube (if applicable)



- WARNING -

- Do not pour water directly into the unit.

Cleaning agents and tools

- pH-neutral all-purpose cleaners.
- Use a brush, a soft cloth, or a vacuum cleaner.

Remove the elastic water trap, located on the back of the cabinet, as illustrated. Inspect the defrost water tube for obstructions. Rinse and clean it and reinstall.

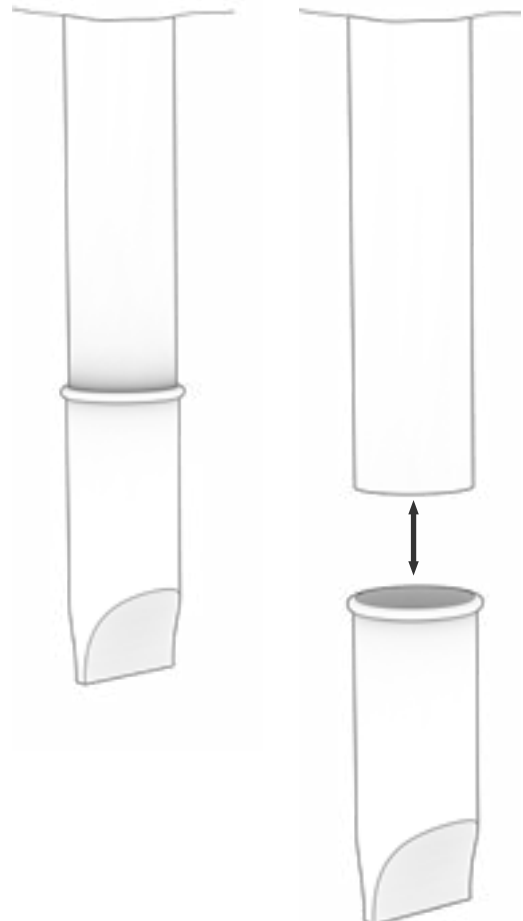

FAQ

Complication	Cause	Approach
Temperature fluctuations	Frequent door openings	<ul style="list-style-type: none"> Make the door openings as brief as possible.
	Malfunctioning temperature sensor	<ul style="list-style-type: none"> Use an independent temperature measurement device to measure the temperature inside the refrigerator/freezer to evaluate if it differs from the readings of the sensors in the appliance. In case of significant temperature difference – contact Gram BioLine technical support.
	Dirty condenser	<ul style="list-style-type: none"> Clean the condenser.
	Item distribution	<ul style="list-style-type: none"> Ensure that the contents are evenly distributed and do not obstruct air circulation.
	Ambient conditions	<ul style="list-style-type: none"> Ensure that the ambient temperature does not exceed the specified limits in this instructions for use. Ensure the cabinet is not in direct contact with sunlight or effected by other heat sources. The user must ensure that the cabinet is used in accordance with its intended use and that the humidity does not exceed 70%. Ensure adequate ventilation around the refrigerator/freezer. (Refer to surroundings section)
	Item temperature	<ul style="list-style-type: none"> Ensure that all contents are at set temperature before they are placed inside the refrigerator/freezer.
The refrigerator/freezer is not working	Power supply	<ul style="list-style-type: none"> Ensure that the power cord is securely plugged into the socket and the refrigerator/freezer.
	Power outage	<ul style="list-style-type: none"> Keep the door closed. Use a backup power source if available. Move contents to a working unit if available.
	Faulty outlet	<ul style="list-style-type: none"> Check for blown fuses. Check the circuit breaker and RCD (Residual Current Device).

- INFORMATION -

 If any issues persist, do not hesitate to reach out to Gram BioLine for professional support, at support@gram-bioline.com.

Complication	Cause	Approach
Noisy	Unlevel refrigerator/freezer	<ul style="list-style-type: none"> • Ensure that the floor is level. • Ensure that the base of the refrigerator/freezer is level. (Refer to installation section).
	Direct contact with other objects	<ul style="list-style-type: none"> • Ensure that the refrigerator/freezer is not in contact with the wall. • Ensure that the refrigerator/freezer is not in contact with another appliance or other objects.
	Fans (if applicable)	<ul style="list-style-type: none"> • Ensure the fans are operational and does not make any abnormal sounds.
Refrigerator/freezer unable to reach set temperature	Discrepancy between E-sensor and set temperature	<ul style="list-style-type: none"> • The display may show a different temperature because the E-sensor is located at the warmest spot in the unit. <p>However, the temperature in the central area where contents are stored should be at the set temperature.</p> <p>Verify this with an independent temperature measurement. If you have concerns, please contact our customer support team.</p>
	Damaged door gasket	<ul style="list-style-type: none"> • Ensure that the gasket is pliable and in good working order.
Need for spare parts	Replacement parts are required	<ul style="list-style-type: none"> • If you require spare parts, please contact your local Gram BioLine distributor.

- INFORMATION -

 If any issues persist, do not hesitate to reach out to Gram BioLine for professional support, at support@gram-bioline.com.

Installation & Operation Qualification

The following IQ / OQ is intended to be a guideline, local IQ / OQ procedures can vary depending on application and items stored in the Gram BioLine cabinet.

Deviations from the specifications dictated in the PQ are to be reported in the deviation report.

The PQ is concluded if all criteria of acceptance are approved and the possible deviations are rectified or accepted.

Organisation:

Location of installation:

Model:

Serial number:

Item and revision number of instructions for use:

Status of operation:

- Active
 Inactive

Name of vendor:

Warranty:

Start: _____

End: _____

Model: _____

SN: _____

Instructions on use to starting the cabinet:

1. Training of the responsible party Date: _____ By: _____

2. Operational test of the cabinet Date: _____ By: _____

3. Responsible party _____ Tel: _____

Instructions to users:

The responsible party is trained in use of the cabinet in reference to the user manual

General use of cabinet

Objections to the mentioned:

Service & maintenance

The cabinet was delivered without defects/damage.
The cabinet started as specified in the user manual

Set values:

Setpoint temperature _____ °C

Local alarm settings

High temperature alarm _____ °C

Low temperature alarm _____ °C

External alarm settings

(See voltage free contact in user manual)

High temperature alarm _____ °C

Low temperature alarm _____ °C

Factory settings:

Model / Setpoint temp.	LhL	LLL	EhL	ELL
BioUltra UL570	-80 °C	+25 °C	-99 °C	+25 °C

Date: _____ Name of trained user: _____ Signature: _____ Name of instructor: _____ Signature: _____

Model: _____ SN: _____

Installation Qualification – IQ

ID	Description of installation	Reference in manual	Comply		Attachment	Notes
			YES	NO		
I-0	The cabinet is shipped with a transport bracket that should be removed prior to use.	N/A				
I-1	Ensure the cabinet is installed indoors.	page 8				
I-2	Ensure the cabinet is installed in a dry and sufficiently ventilated area.	page 8				
I-3	Ensure the cabinet is not in direct contact with sunlight or other heat sources.	page 8				
I-4	Ensure that the ambient operating temperature is within the allowed range.	page 8				
I-5	Ensure that the cabinet is not installed in a chloric/acidic environment.	page 8				
I-6	Ensure that the protective film on the cabinet is removed.	page 8				
I-7	Ensure that the cabinet is cleaned with a mild soap solution	page 8				
I-8	Ensure that the cabinet has stood upright for 24 hours if the cabinet has been laying down.	page 8				
I-9	Ensure that the cabinet is levelled if it is equipped with legs.	page 9				
I-10	Ensure a level surface if the cabinet is equipped with wheels/castors.	page 9				
I-11	If equipped with wheels/castors: Ensure wheels/castors are locked after positioning	page 9				
I-12	If equipped with drawers and/or glass door: Ensure that tilt-bracket is mounted.	N/A				
I-13	Ensure a distance of 15-75 mm between cabinet and back wall.	page 10				
I-14	Ensure that there is a minimum gap of 30 mm between cabinets.	page 11				
I-15	Ensure that the upper part of the cabinet is not covered.	page 11				
I-16	Ensure that electrical appliances are not being used inside the cabinet.	page 12				
I-17	Ensure connection from voltage-free contact to external monitoring system	page 13				

Installation Qualification – IQ

ID	Description of installation	Reference in manual	Comply		Attachment	Notes
			YES	NO		
I-18	Ensure that the inner doors can operate in accordance with the instructions.	page 14				
I-19	Ensure the correct electrical connection (compare local values with type/nr plate)	page 16				
I-20-1	Ensure that the power cord is secured by the preload cover	page 16				
I-20-2	Ensure that the power cord is secured by the hanger	N/A				
I-21	Mark power cord with: "Do not separate when energized".	page 16				
I-22-1	Ensure equipotential bonding (applicable for ATEX Cat.3 Zone 2 areas)	page 18				

Model: _____

SN: _____

Operation Qualification – OQ

ID	Description of installation	Reference in manual	Comply		Attachment	Notes
			YES	NO		
O-1	Turn on the cabinet – Display test (software version and variant).	page 20				
O-2	Set/adjust set-point temperature.	page 20				
O-3	Set/adjust LhL – Upper alarm limit (local).	page 23				
O-4	Set/adjust LLL – Lower alarm limit (local).	page 23				
O-5	Set/adjust Lhd – Delay of the upper alarm limit (local).	page 24				
O-6	Set/adjust LLd – Delay of the lower alarm limit (local).	page 24				
O-7	Activate / deactivate dA – Door alarm (local).	N/A				
O-8	Set/adjust dAd – Delay of the door alarm (local).	N/A				
O-9	Activate / deactivate BU – Acoustic alarms (local).	page 25				
O-10	Set/adjust EhL – Upper alarm limit (external).	page 26				
O-11	Set/adjust ELL – Lower alarm limit (external).	page 26				
O-12	Set/adjust Ehd – Delay of the upper alarm limit (external).	page 27				
O-13	Set/adjust ELd – Delay of the lower alarm limit (external).	page 27				
O-14	Activate / deactivate dA – Door alarm (external)	N/A				
O-15	Set/adjust dAd – Delay of the door alarm (external).	N/A				
O-16	Activate / deactivate BU – Acoustic external alarms.	page 28				
O-17	Set/adjust defrost cycles (deF) per 24 hours (factory setting: 4).	N/A				
O-18	Select reference sensor for the display (dPs) (A or E).	page 32				

Model: _____

SN: _____

Deviation Report

Deviations to the criteria of acceptance are to be documented in the deviation report. A separate deviation report shall be made for each deviation. Mark the entry with the relevant “-ID” specified in the left column in the test specifications.

-ID: _____

Description of deviation:

Extent to which the deviation has been alleviated:

Additional notes:

Person responsible for test:	Person responsible for verification of test:
Name: _____	Name: _____
Date: _____	Date: _____
Organisation: _____	Organisation: _____
Signature: _____	Signature: _____

Model: _____ SN: _____

Approval of test results – Installation Qualification (IQ)

- The steps in the Installation Qualification – IQ were completed with positive results
- The steps in the Installation Qualification – IQ were completed with negative results

ID of steps with negative results: _____

Approval of test results – Operation Qualification (OQ)

- The steps in the Operation Qualification – OQ were completed with positive results
- The steps in the Operation Qualification – OQ were completed with negative results

ID of steps with negative results: _____

Organisation / Responsible party: _____

Trainer / Responsible party: _____

Stamp & Signature

Stamp & Signature

Tel.

Tel.

E-mail

E-mail

Location & Date

Location & Date

Model: _____

SN: _____

Performance Qualification

Organisation:

Location of installation:

Model: _____ SN: _____ Item number: _____
(manual)

The PQ consists of inspections of the correct operation of the cabinet under predefined conditions and procedures. Prerequisites for the PQ are IQ (Installation Qualification) and OQ (Operation Qualification), these must be concluded successfully prior to the initiation of the PQ.

Person responsible for the cabinet:

Name: _____
Date: _____
Signature: _____

Person responsible for test:

Name: _____
Date: _____
Organisation: _____
Signature: _____

Person responsible for verification of test:

Name: _____
Date: _____
Organisation: _____
Signature: _____

Test duration:

Initiation (date/time): _____
Conclusion (date/time): _____
Date: _____
Organisation: _____
Signature: _____

Model: _____ SN: _____

Deviations from the specifications dictated in the PQ, are to be reported in the deviation report.
 The PQ is concluded if all criteria of acceptance are approved and the possible deviations are rectified or accepted.

Measurement – Prerequisites

ID	Description	Accepted	
		Yes	No
P-1	The cabinet must be empty while conducting tests, ie without interior fittings such as drawers, shelves etc. Attachment: Notes:		
P-2	The measurements must be conducted in accordance to IEC 60068-3-5. Attachment: Notes:		
P-3	The positioning of the sensors in the cabinet must be documented with a sketch and/or a photograph. Attachment: Notes:		

Name:

Signature:

Approved
(Yes / No):

Date:

Conducted by:

Inspected / verified by:

Model: _____

SN: _____

Deviations from the specifications dictated in the PQ, are to be reported in the deviation report.
 The PQ is concluded if all criteria of acceptance are approved and the possible deviations are rectified or accepted.

Measurement – Prerequisites

ID	Description	Accepted	
		Yes	No
P-4	Measurements made during the PQ tests must be documented and attached to the PQ. Attachment: Notes:		
P-5	Specify setpoint temperature: _____ °C Specify the ambient temperature: _____ °C Attachment: Notes:		
P-6	Allowed tolerances – Select the tolerance, according to the model being tested. Find model-specific tolerances in appendix. Tolerance: +/- _____ K Attachment: Notes:		

Name: _____ Signature: _____ Approved (Yes / No): _____ Date: _____
 Conducted by: _____
 Inspected / verified by: _____
 Model: _____ SN: _____

Deviations from the specifications dictated in the PQ, are to be reported in the deviation report.
 The PQ is concluded if all criteria of acceptance are approved and the possible deviations are rectified or accepted.

Measurement – Temperature stabilization

ID	Description	Accepted	
		Yes	No
P-7	<p>The test is intended to provide substantiation for the temperature stability inside the cabinet during normal operation.</p> <p>The temperature inside the cabinet must be stabilized – where all the points in the working space have reached and maintained the same temperature.</p> <p>When the system is stable, document ordinary operation of the cabinet at the setpoint temperature and ambient temperature specified in P-5.</p> <p>Duration: _____</p> <p>The measurements throughout the operation test, must be documented and attached the PQ.</p> <p>Attachment:</p> <p>Notes:</p>		
P-8	<p>Are the measurements inside the allowed tolerances specified in P-6 ?</p> <p>Attachment:</p> <p>Notes:</p>		

Name: _____ Signature: _____ Approved (Yes / No): _____ Date: _____

Conducted by: _____

Inspected / verified by: _____

Model: _____ SN: _____

Deviations from the specifications dictated in the PQ, are to be reported in the deviation report.
 The PQ is concluded if all criteria of acceptance are approved and the possible deviations are rectified or accepted.

Measurement – Door opening test

ID	Description	Accepted	
		Yes	No
P-9	<p>The test is intended to provide substantiation for the temperature recovery time inside the cabinet subsequently after a door opening.</p> <p>The temperature inside the cabinet must be stabilized – where all the points in the working space have reached and maintained the same temperature, the setpoint temperature is specified in P-5.</p> <p>When the system is stable, open the door at 90° for 60 seconds.</p> <p>The measurements, throughout the door opening test, must be documented and attached the PQ.</p> <p>Duration: _____</p> <p>Attachment:</p> <p>Notes:</p>		
P-10	<p>Has the setpoint temperature specified in P-5, measured in the absolute centre of the cabinet, been achieved within the set time-frame specified in the appendix?</p> <p>Attachment:</p> <p>Notes:</p>		

Name: _____ Signature: _____ Approved (Yes / No): _____ Date: _____

Conducted by: _____

Inspected / verified by: _____

Model: _____ SN: _____

Deviations from the specifications dictated in the PQ, are to be reported in the deviation report.
 The PQ is concluded if all criteria of acceptance are approved and the possible deviations are rectified or accepted.

Measurement – Pull-down

ID	Description	Accepted	
		Yes	No
P-11	<p>The test is intended to provide substantiation for the time it takes for the inside of the cabinet to reach the setpoint temperature specified in P-5. The initial temperature in the working space is the ambient temperature specified in P-5. The temperature inside the cabinet must be stabilized in all points of the working space.</p> <p>When the system is stable. Turn on the power to the cabinet.</p> <p>The measurements, throughout the pull-down test, must be documented and attached the PQ.</p> <p>Duration: _____</p> <p>Attachment:</p> <p>Notes:</p>		
P-12	<p>The time it takes the inside of the cabinet to achieve the setpoint temperature measured in the absolute centre, must not exceed the time-frame specified in the appendix.</p> <p>Have the criteria been met?</p> <p>Attachment:</p> <p>Notes:</p>		

Name: _____ Signature: _____ Approved (Yes / No): _____ Date: _____

Conducted by: _____

Inspected / verified by: _____

Model: _____ SN: _____

Deviations from the specifications dictated in the PQ, are to be reported in the deviation report.
 The PQ is concluded if all criteria of acceptance are approved and the possible deviations are rectified or accepted.

Measurement – Hold-over			
ID	Description	Accepted	
		Yes	No
P-13	<p>The test is intended to provide substantiation for the time it takes for the temperature inside the cabinet to reach the end temperature specified in the appendix. Ambient temperature and setpoint temperature is specified in P-5.</p> <p>The temperature inside the cabinet must be stabilized – where all the points in the working space have reached and maintained the same temperature throughout, the tolerances are specified in P-6.</p> <p>When the system is stable, turn off the power to the cabinet.</p> <p>The measurements, throughout the hold-over test, must be documented and attached the PQ.</p> <p>Attachment:</p> <p>Notes:</p>		
P-14	<p>The times it takes the inside of the cabinet to reach the end temperature, must at least be the time specified in the appendix.</p> <p>Duration: _____</p> <p>Have the criteria been met?</p> <p>Attachment:</p> <p>Notes:</p>		

Name: _____ Signature: _____ Approved (Yes / No): _____ Date: _____

Conducted by: _____

Inspected / verified by: _____

Model: _____ SN: _____

Deviation Report

Deviations to the criteria of acceptance are to be documented in the deviation report. A separate deviation report shall be made for each deviation. Mark the entry with the relevant "P-ID" specified in the left column in the test specifications.

P-ID: _____

Description of deviation:

Extent to which the deviation has been alleviated:

Additional notes:

Person responsible for test:

Name: _____

Date: _____

Organisation: _____

Signature: _____

Person responsible for verification of test:

Name: _____

Date: _____

Organisation: _____

Signature: _____

Model: _____

SN: _____

Approval of test results – Performance Qualification (PQ)

- The steps in the Performance Qualification – PQ were completed with positive results
- The steps in the Performance Qualification – PQ were completed with negative results

ID of steps with negative results: _____

Additional notes:

Organisation / Responsible party: _____

Trainer / Responsible party: _____

Stamp & Signature

Stamp & Signature

Tel. _____

Tel. _____

E-mail _____

E-mail _____

Location & Date _____

Location & Date _____

Model: _____ SN: _____

Appendix:

	Model	Tolerances	Door opening - recovery time	Pull-down	Hold-over range*	Hold-over
UL	BioUltra UL570	+/- 5K	45 Minutes	300 Minutes	-80/-60 °C	150 Minutes

* The temperature span between the initial temperature and the end temperature in the hold-over test P-13,14.

Name: _____ Signature: _____ Approved (Yes / No): _____ Date: _____
 Conducted by: _____

Inspected / verified by: _____

Model: _____ SN: _____

Index

A	
Access port	39
Alarm settings, external.	26
Alarm settings, local.	23
B	
Boxes and racks	41
C	
Cabinet components	6
Cleaning	33, 59, 60
Connection to power	16
Connection to water supply	19
D	
Data sheet	45
Declaration of conformity	55
Defrosting	35
Digital display	20
Display sensor.	32
Disposal	44
Door gasket	34
Door handle	13, 14, 42
Door lock	40
E	
Equalisation valve.	36
Equipotential bonding	18
Error codes	22
Escorted/set alarm limits.	31
F	
FAQ	64
G	
General info.	37
I	
Important.	43
Initial setup	8
Installation.	8
IQ, OQ, PQ	66, 74
M	
Maintenance	33, 56, 57
Menu	21
Mounting of shelves.	12
Mount/unmount door handle	42
P	
Parameter settings.	29
Q	
Quick Guide.	2
R	
Refrigeration circuits	49
Responsibility	37
S	
Safety	5
Sensor offset	29
Start-up	20
Surroundings.	10
Symbols	5
T	
Table of content	4
Type/number plate.	38
V	
Voltage-free contact.	15
W	
Wiring diagram	54

Gram Scientific ApS

Aage Grams Vej 1 · 6500 Vojens · Danmark

Tel: +45 73 20 13 00

e-mail : info@gram-bioline.com

www.gram-bioline.com



Biostorage you can depend on